

GENERAL NOTES

1. SEE GN001 TO GN004 FOR ABBREVIATIONS, SYMBOLS AND LINETYPES.
2. SEE BG, SL AND ST SERIES SHEETS FOR STRUCTURAL AND FOUNDATION DETAILS.
3. REFER TO SR 99 ALIGNMENT/RIGHT OF WAY PLANS FOR HORIZONTAL AND VERTICAL DATUM.
4. AS-BUILT PLANS FOR THE EXISTING STRUCTURE ARE AVAILABLE FROM THE ENGINEER.

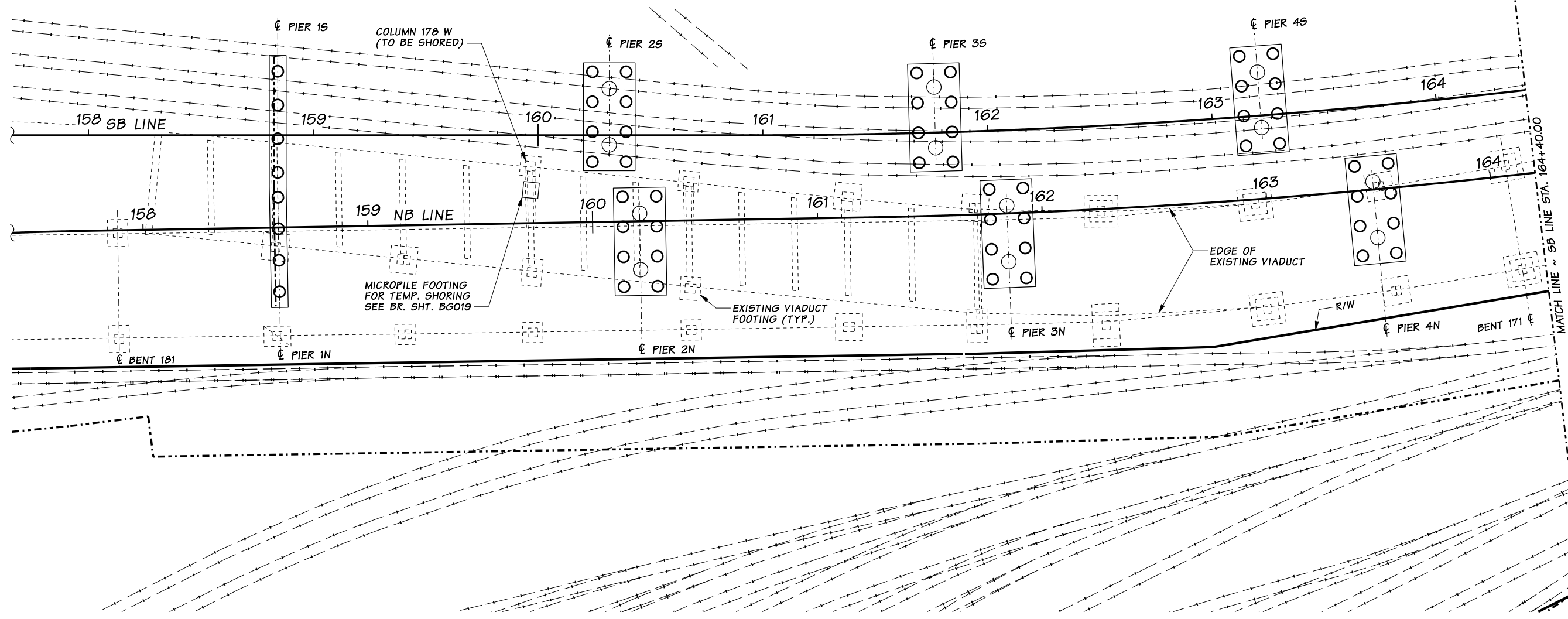

PROJECT FOUNDATION PLAN 1

SR 99 FILE NO. SHEET GB001

Bridge Design Engr.	Khaleghi, B	c:\aawork\pwwork\law\evansa\dms08180\160073-S00-SBBG401.DLV	
Supervisor	Moore, TM	REGION NO.	STATE
Designed By	Mizumori, A	10	WASH.
Checked By	Moore, TM	JOB NUMBER	
Detailed By	Evans, A	09A803	
Bridge Projects Engr.			
Prelim. Plan By	2/17/10	REVISED SHEET	AM TMM
Architect/Specialist	DATE	REVISION	BY APPD

FED. AID. PROJ. NO.	SHEET NO.	TOTAL SHEETS



BRIDGE AND STRUCTURES OFFICE

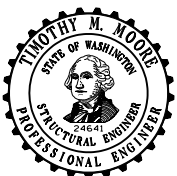

SR 99 ALASKAN WAY VIADUCT - REPLACEMENT S HOLGATE ST TO S KING ST - STAGE 2

PROJECT FOUNDATION PLAN

BRIDGE SHEET NO.	GB001
SHEET OF	836 OF 1475
SHEETS	

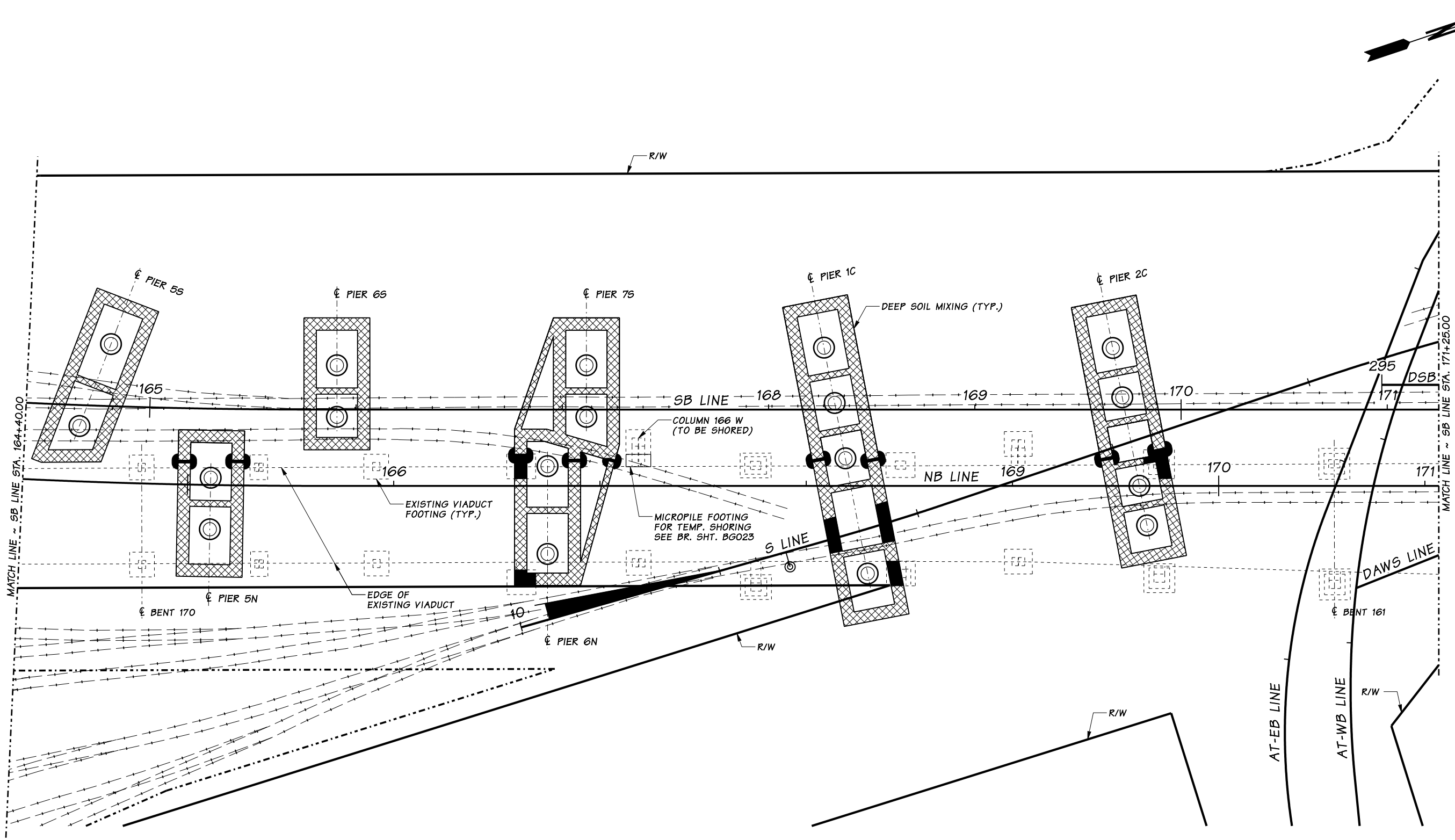

PROJECT FOUNDATION PLAN 2

SEE GB001 FOR GENERAL NOTES

SR 99 FILE NO. SHEET GB002

Bridge Design Engr.	Khaleghi, B	c:\aawork\pwwork\law\evansa\dms08180\160073-S00-SBBG402.DLV	
Supervisor	Moore, TM	REGION NO.	STATE
Designed By	Mizumori, A	10	WASH.
Checked By	Moore, TM	JOB NUMBER	
Detailed By	Evans, A	09A803	
Bridge Projects Engr.		DATE	REVISION
Prelim. Plan By		2/17/10	REVISED SHEET
Architect/Specialist			
		BY	APP'D

FED. AID. PROJ. NO.	SHEET NO.	TOTAL SHEETS



BRIDGE AND STRUCTURES OFFICE

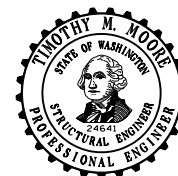

Washington State Department of Transportation

SR 99 ALASKAN WAY VIADUCT - REPLACEMENT S HOLGATE ST TO S KING ST - STAGE 2

PROJECT FOUNDATION PLAN

BRIDGE SHEET NO.	GB002
SHEET OF	837 OF 1475
SHEETS	

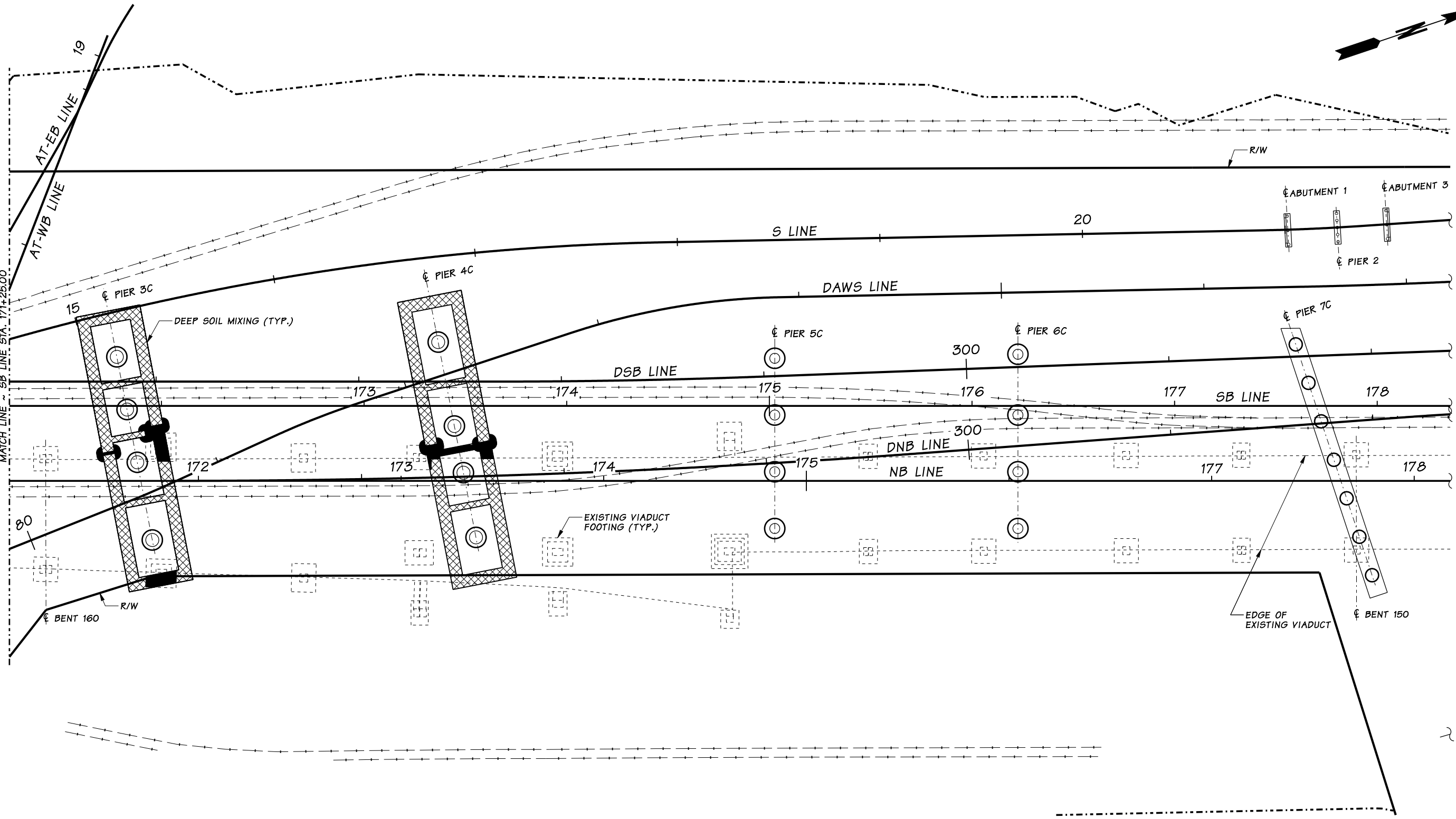

PROJECT FOUNDATION PLAN 3

SEE GB001 FOR GENERAL NOTES

SR 99 FILE NO. SHEET GB003

Bridge Design Engr.	Khaleghi, B	c:\aawork\pwwork\law\levans\dms08180\160073-S00-SBBG403.DLV	
Supervisor	Moore, TM	REGION NO.	STATE
Designed By	Mizumori, A	10	WASH.
Checked By	Moore, TM	JOB NUMBER	
Detailed By	Evans, A	09A803	
Bridge Projects Engr.			
Prelim. Plan By	2/17/10	REVISED SHEET	AM TMM
Architect/Specialist	DATE	REVISION	BY APPD

2/12/2010 10:57:08 AM

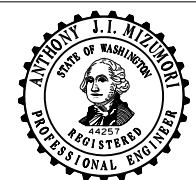

BRIDGE AND STRUCTURES OFFICE

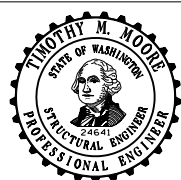

Washington State Department of Transportation

SR 99 ALASKAN WAY VIADUCT - REPLACEMENT S HOLGATE ST TO S KING ST - STAGE 2

PROJECT FOUNDATION PLAN

BRIDGE SHEET NO.	GB003
SHEET	838
OF	1475
SHEETS	

C.S. 1791 PROJ. NO. XL3237A UCO REGION ~ SR 99 ~ S HOLGATE ST TO S KING ST ~ BRIDGE NO. 99/540 NB & SB REPLACEMENT

SHEET INDEX 1

AWV NB & SB LINES	
BRIDGE SHEET NO.	SHEET TITLE
IB001	STRUCTURAL SHEET INDEX
BG000	ABBREVIATIONS AND KEY MAP
BG003	LAYOUT 1
BG004	LAYOUT 2
BG005	LAYOUT 3
BG006	LAYOUT 4
BG007	LAYOUT 5
BG008	LAYOUT 6
BG009	GENERAL NOTES
BG010	GEOMETRIC DATA
BG011	CONSTRUCTION SEQUENCE
BG012	CONSTRUCTION STAGING - DETAILS 1 OF 2
BG013	CONSTRUCTION STAGING - DETAILS 2 OF 2
BG014	CRANE LOCATION FOR GIRDER PLACEMENT - PHASE 1
BG015	CRANE LOCATION FOR GIRDER PLACEMENT - PHASE 2
BG016	FOUNDATION PLAN 1 OF 3
BG017	FOUNDATION PLAN 2 OF 3
BG018	FOUNDATION PLAN 3 OF 3
BG019	TEMPORARY SUPPORT AT BENT 178 - DETAILS 1 OF 4
BG020	TEMPORARY SUPPORT AT BENT 178 - DETAILS 2 OF 4
BG021	TEMPORARY SUPPORT AT BENT 178 - DETAILS 3 OF 4
BG022	TEMPORARY SUPPORT AT BENT 178 - DETAILS 4 OF 4
BG023	TEMPORARY SUPPORT AT BENT 166 - DETAILS 1 OF 3
BG024	TEMPORARY SUPPORT AT BENT 166 - DETAILS 2 OF 3
BG025	TEMPORARY SUPPORT AT BENT 166 - DETAILS 3 OF 3
BG026	PIER 15 PILE DETAILS
BG027	PIER 15 PLAN
BG028	PIER 15 ELEVATION
BG029	PIER 15 SECTION
BG030	PIER 15 DETAILS
BG031	PIER 15 CURTAIN WALL ELEVATION
BG032	PIER 25 PILE DETAILS
BG033	PIER 25 PILE CAP PLAN
BG034	PIER 25 PILE CAP ELEVATION
BG035	PIER 25 COLUMN DETAILS
BG036	PIER 25 CROSSBEAM - PLAN AND ELEVATION
BG037	PIER 25 CROSSBEAM DETAILS 1 OF 2
BG038	PIER 25 CROSSBEAM DETAILS 2 OF 2
BG039	PIER 35 PILE DETAILS
BG040	PIER 35 PILE CAP PLAN
BG041	PIER 35 PILE CAP ELEVATION

AWV NB & SB LINES (CONTINUED)	
BRIDGE SHEET NO.	SHEET TITLE
BG042	PIER 35 COLUMN DETAILS
BG043	PIER 35 CROSSBEAM - PLAN AND ELEVATION
BG044	PIER 35 CROSSBEAM DETAILS 1 OF 2
BG045	PIER 35 CROSSBEAM DETAILS 2 OF 2
BG046	PIER 45 PILE DETAILS
BG047	PIER 45 PILE CAP PLAN
BG048	PIER 45 PILE CAP ELEVATION
BG049	PIER 45 COLUMN DETAILS
BG050	PIER 45 CROSSBEAM - PLAN AND ELEVATION
BG051	PIER 45 CROSSBEAM DETAILS
BG052	PIER 55 SHAFT DETAILS
BG053	PIER 55 COLUMN DETAILS
BG054	PIER 55 CROSSBEAM - PLAN AND ELEVATION
BG055	PIER 55 CROSSBEAM DETAILS 1 OF 2
BG056	PIER 55 CROSSBEAM DETAILS 2 OF 2
BG057	PIER 65 SHAFT DETAILS
BG058	PIER 65 COLUMN DETAILS
BG059	PIER 65 CROSSBEAM - PLAN AND ELEVATION
BG060	PIER 65 CROSSBEAM DETAILS 1 OF 2
BG061	PIER 65 CROSSBEAM DETAILS 2 OF 2
BG062	PIER 75 SHAFT DETAILS
BG063	PIER 75 COLUMN DETAILS
BG064	PIER 75 CROSSBEAM - PLAN AND ELEVATION
BG065	PIER 75 CROSSBEAM DETAILS 1 OF 2
BG066	PIER 75 CROSSBEAM DETAILS 2 OF 2
BG067	PIER 1N PILE DETAILS
BG068	PIER 1N PLAN
BG069	PIER 1N ELEVATION
BG070	PIER 1N SECTION
BG071	PIER 1N DETAILS
BG072	PIER 1N CURTAIN WALL ELEVATION
BG073	PIER 2N PILE DETAILS
BG074	PIER 2N PILE CAP PLAN
BG075	PIER 2N PILE CAP ELEVATION
BG076	PIER 2N COLUMN DETAILS
BG077	PIER 2N CROSSBEAM - PLAN AND ELEVATION
BG078	PIER 2N CROSSBEAM DETAILS 1 OF 2
BG079	PIER 2N CROSSBEAM DETAILS 2 OF 2
BG080	PIER 3N PILE DETAILS
BG081	PIER 3N PILE CAP PLAN
BG082	PIER 3N PILE CAP ELEVATION

AWV NB & SB LINES (CONTINUED)	
BRIDGE SHEET NO.	SHEET TITLE
BG083	PIER 3N COLUMN DETAILS
BG084	PIER 3N CROSSBEAM - PLAN AND ELEVATION
BG085	PIER 3N CROSSBEAM DETAILS 1 OF 2
BG086	PIER 3N CROSSBEAM DETAILS 2 OF 2
BG087	PIER 4N PILE DETAILS
BG088	PIER 4N PILE CAP PLAN
BG089	PIER 4N PILE CAP ELEVATION
BG090	PIER 4N COLUMN DETAILS
BG091	PIER 4N CROSSBEAM - PLAN AND ELEVATION
BG092	PIER 4N CROSSBEAM DETAILS
BG093	PIER 5N SHAFT DETAILS
BG094	PIER 5N COLUMN DETAILS
BG095	PIER 5N CROSSBEAM - PLAN AND ELEVATION
BG096	PIER 5N CROSSBEAM DETAILS 1 OF 2
BG097	PIER 5N CROSSBEAM DETAILS 2 OF 2
BG098	PIER 6N SHAFT DETAILS
BG099	PIER 6N COLUMN DETAILS
BG100	PIER 6N CROSSBEAM - PLAN AND ELEVATION
BG101	PIER 6N CROSSBEAM DETAILS 1 OF 2
BG102	PIER 6N CROSSBEAM DETAILS 2 OF 2
BG103	PIER 1C SHAFT DETAILS
BG104	PIER 1C COLUMN DETAILS
BG105	PIER 1C CROSSBEAM - PLAN AND ELEVATION
BG106	PIER 1C CROSSBEAM DETAILS 1 OF 3
BG107	PIER 1C CROSSBEAM DETAILS 2 OF 3
BG108	PIER 1C CROSSBEAM DETAILS 3 OF 3
BG109	PIER 2C SHAFT DETAILS
BG110	PIER 2C COLUMN DETAILS
BG111	PIER 2C CROSSBEAM - PLAN AND ELEVATION
BG112	PIER 2C CROSSBEAM DETAILS 1 OF 2
BG113	PIER 2C CROSSBEAM DETAILS 2 OF 2
BG114	PIER 3C SHAFT DETAILS
BG115	PIER 3C COLUMN DETAILS
BG116	PIER 3C CROSSBEAM - PLAN AND ELEVATION
BG117	PIER 3C CROSSBEAM DETAILS 1 OF 3
BG118	PIER 3C CROSSBEAM DETAILS 2 OF 3
BG119	PIER 3C CROSSBEAM DETAILS 3 OF 3
BG120	PIER 4C SHAFT DETAILS
BG121	PIER 4C COLUMN DETAILS
BG122	PIER 4C CROSSBEAM - PLAN AND ELEVATION
BG123	PIER 4C CROSSBEAM DETAILS 1 OF 3

AWV NB & SB LINES (CONTINUED)	
BRIDGE SHEET NO.	SHEET TITLE
BG124	PIER 4C CROSSBEAM DETAILS 2 OF 3
BG125	PIER 4C CROSSBEAM DETAILS 3 OF 3
BG126	PIER AND CASING DETAILS
BG127	PIER 5C SHAFT DETAILS
BG128	PIER 5C COLUMN DETAILS
BG129	PIER 5C CROSSBEAM - PLAN AND ELEVATION
BG130	PIER 5C CROSSBEAM DETAILS 1 OF 2
BG131	PIER 5C CROSSBEAM DETAILS 2 OF 2
BG132	PIER EXCAVATION DETAILS
BG133	PIER 6C SHAFT DETAILS
BG134	PIER 6C COLUMN DETAILS
BG135	PIER 6C CROSSBEAM - PLAN AND ELEVATION
BG136	PIER 6C CROSSBEAM DETAILS 1 OF 3
BG137	PIER 6C CROSSBEAM DETAILS 2 OF 3
BG138	PIER 6C CROSSBEAM DETAILS 3 OF 3
BG139	PIER 7C SHAFT DETAILS
BG140	PIER 7C PLAN AND ELEVATION
BG141	PIER 7C DETAILS
BG142	PIER 7C CURTAIN WALL - DETAILS 1 OF 2
BG143	PIER 7C CURTAIN WALL - DETAILS 2 OF 2
BG144	BEARING DETAILS
BG145	TYPICAL SECTION NB & SB
BG146	TYPICAL SECTION SPANS 1C TO 5C
BG147	TYPICAL SECTION SPAN 6C
BG148	FRAMING PLAN SPANS 15 AND 25
BG149	FRAMING PLAN SPANS 35 AND 45
BG150	FRAMING PLAN SPANS 55, 65 AND 75
BG151	FRAMING PLAN SPANS 1N AND 2N
BG152	FRAMING PLAN SPANS 3N AND 4N
BG153	FRAMING PLAN SPANS 5N AND 6N
BG154	FRAMING PLAN SPAN 1C
BG155	FRAMING PLAN SPAN 2C
BG156	FRAMING PLAN SPAN 3C
BG157	FRAMING PLAN SPAN 4C
BG158	FRAMING PLAN SPAN 5C
BG159	FRAMING PLAN SPAN 6C

SR 99 FILE NO. SHEET 1B001

Bridge Design Engr. Khaleghi, B	M:\Y-Team\AWV SOUTH INTERCHANGE\window files\Index 1.WND		REGION NO.	STATE	FED. AID PROJ. NO.	SHEET NO.	TOTAL SHEETS
Supervisor Moore, TM			10	WASH.			
Designed By			JOB NUMBER 09A803				
Checked By							
Detailed By							
Bridge Projects Engr.							
Prelim. Plan By	2/17/10	REVISED SHEET	CSL	TMM			
Architect/Specialist	DATE	REVISION	BY	APPD			



BRIDGE AND STRUCTURES OFFICE



**SR 99
ALASKAN WAY VIADUCT - REPLACEMENT
S HOLGATE ST TO S KING ST - PHASE 2**
BRIDGE NO. 99/540 NB & SB
STRUCTURAL SHEET INDEX

BRIDGE SHEET NO. **1B001**
SHEET **847** OF **1475** SHEETS

LEGEND

-  IDENTIFIES SECTION, VIEW OR DETAIL
-  TAKEN OR SHOWN ON BRIDGE SHEET BG003
-  TAKEN OR SHOWN ON THE SAME SHEET

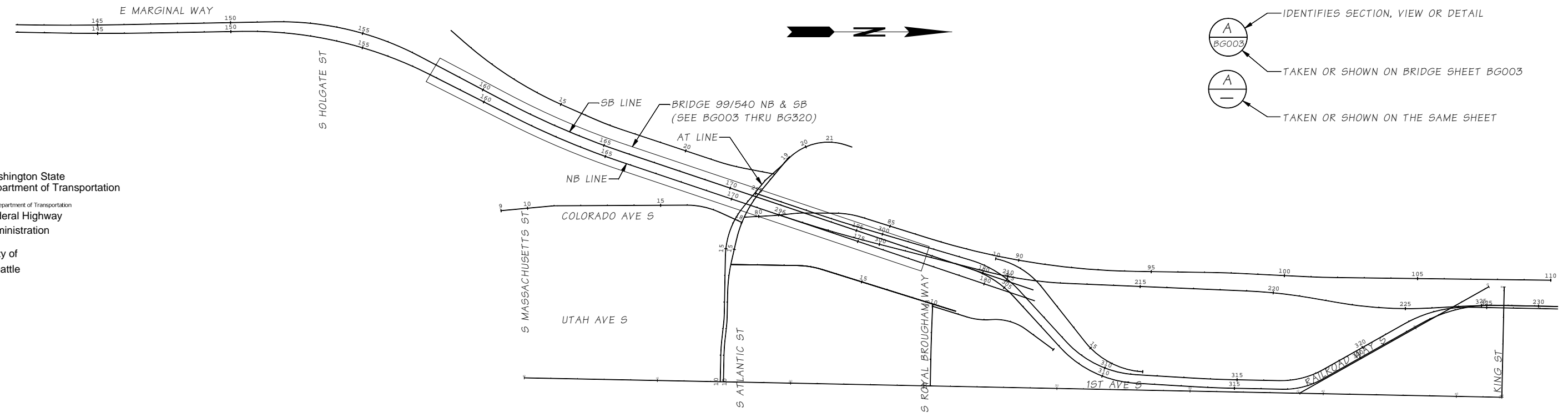

KEY MAP

&	AND	CF	CUBIC FEET	LC	LENGTH OF CURVE	RDWY	ROADWAY
@	AT	CG	CENTER OF GRAVITY	LONG, LONGIT	LONGITUDINAL	RT	RIGHT
∅	DIAMETER	CIP	CAST-IN-PLACE	LS	LUMP SUM	R/W	RIGHT OF WAY
⊕	CENTERLINE	CONSTR	CONSTRUCTION	LT	LEFT	SDWK, SW	SIDEWALK
°	DEGREES	CONT	CONTINUOUS	LVC	LENGTH OF VERTICAL CURVE	SEW	STRUCTURAL EARTH WALL
'	FEET, MINUTES	CSL	CROSS SONIC LOGGING	MAINT	MAINTENANCE	SH, SHLD	SHOULDER
'/FT	FEET PER FOOT	DIAPH	DIAPHRAGM	MSE	MECHANICALLY STABILIZED EARTH	SHT	SHEET
"	INCHES, SECONDS	EF	EACH FACE	NAVD 88	NATIONAL AMERICAN VERTICAL DATUM 1988	SPA	SPACE, SPACING
Ⓜ	PLATE	EDPM	ETHYLENE PROPYLENE DIENE M-CLASS RUBBER	NF	NEAR FACE	SPEC	SPECIFICATION
#	POUNDS, NUMBER	ELEV	ELEVATION	NTS	NOT TO SCALE	SPL	SPLICE
%	PERCENT	EPS	EXPANDED POLYSTYRENE	PAVT	PAVEMENT	SR	STATE ROUTE
A	AREA	EXCAV	EXCAVATION	PT	PRECAST, POINT OF CURVATURE	STIFF	STIFFENER
ABUT	ABUTMENT	EXIST	EXISTING	PCCP	PORTLAND CEMENT CONCRETE PAVEMENT	STIRR	STIRRUP
AREMA	AMERICAN RAILWAY ENGINEERING AND MAINTENANCE OF WAY ASSOCIATION	E, EXP	EXPANSION	PED	PEDESTRIAN	TH	TEST HOLE
BH	BORE HOLE	F	FIXED	PI	POINT OF INTERSECTING TANGENTS ON HORIZONTAL CURVE	THW	THERMOPLASTIC HEAT AND WATER RESISTANT INSULATED WIRE THROUGH PLATE GIRDER
BIT	BITUMINOUS	FF	FAR FACE	POC	POINT ON CURVE	TPG	TRANSITION
BK	BACK	FTG	FOOTING	POT	POINT ON TANGENT	TRANS	TRANSVERSE
BOT	BOTTOM	GA	GAUGE	PS	PRESTRESSED	TRANSV	TRANSVERSE
BR	BRIDGE	GALV	GALVANIZED	PSG	PRESTRESSED GIRDER	TYP	TYPICAL
BRG	BEARING	GIR	GIRDER	PT	END OF HORIZONTAL CURVE (POINT OF TANGENCY), POINT	VAR	VARIES
BTW	BETWEEN	H	HEIGHT, HORIZONTALLY RESTRAINED	PTFE	POLYTETRAFLUORETHYLENE	VERT	VERTICAL
CANT	CANTILEVER	HORIZ	HORIZONTAL	PVC	BEGIN VERTICAL CURVE	VC	VERTICAL CURVE
CDF	CONTROL DENSITY FILL	HS	HIGH STRENGTH	PVI	POINT OF INTERSECTING TANGENTS ON VERTICAL CURVE	WM	WILLAMETTE MERIDIAN
		HSS	HOLLOW STRUCTURAL SECTIONS	PVT	END VERTICAL CURVE	WWF	WELDED WIRE FABRIC
				RC	REINFORCED CONCRETE		

ABBREVIATIONS

GENERAL NOTES:

1. SEE GN001 TO GN004 FOR ABBREVIATIONS AND OTHER SYMBOLS AND LINETYPES.

SR 99 FILE NO. SHEET BG000

Bridge Design Engr. Khaleghi, B	M:\Y-Team\AWV SOUTH INTERCHANGE\window files\Prelim Plan BG000.WND					SR 99 ALASKAN WAY VIADUCT - REPLACEMENT S HOLGATE ST TO S KING ST - PHASE 2 BRIDGE NO. 99/540 NB & SB ABBREVIATIONS AND KEY MAP	BRIDGE SHEET NO.	
Supervisor Moore, TM	REGION NO.	STATE	FED. AID PROJ. NO.	SHEET NO.			TOTAL SHEETS	BG000
Designed By	10	WASH.						SHEET
Checked By								879
Detailed By						OF		
Bridge Projects Engr.						1475		
Prelim. Plan By	2/17/10	REVISED SHEET	CSL	TMM		SHEETS		
Architect/Specialist	DATE	REVISION	BY	APPD				

SEC. 7, T.24N., R.4E., W.M.
CITY OF SEATTLE

SR 99

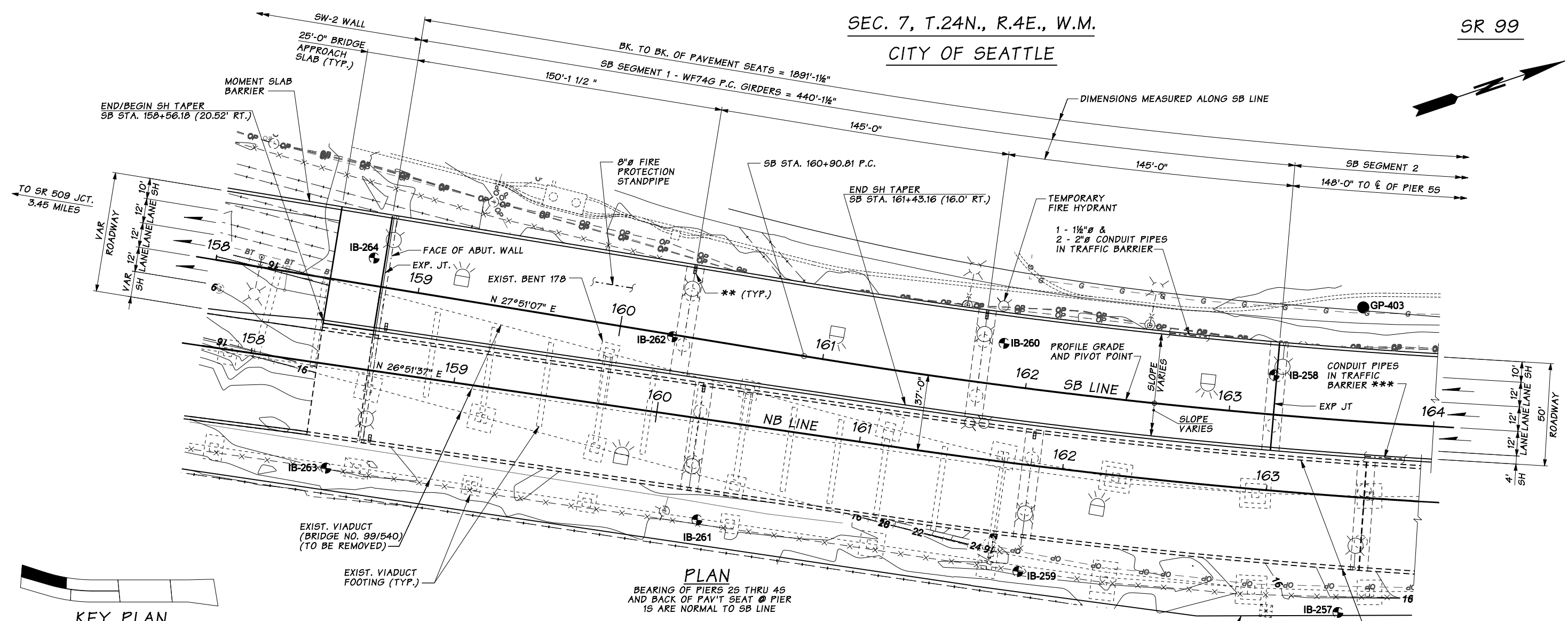

PLAN
BEARING OF PIERS 25 THRU 45 AND BACK OF PAV'T SEAT @ PIER 15 ARE NORMAL TO SB LINE

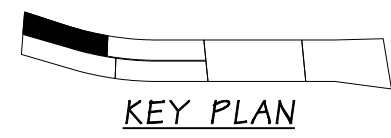

- BORING NUMBER AND APPROXIMATE LOCATION.
- GEOPROBE NUMBER AND APPROXIMATE LOCATION.
- LUMINAIRE
- BRIDGE DRAIN
- UNDERDECK LUMINAIRE
- FIRE HYDRANT

*** SEE CONDUIT SCHEDULE, BR. SH. BG 272
** BRIDGE DRAIN, SEE "BRIDGE DRAIN DETAILS".
NOTES:
1. JUNCTION BOXES AND CONTROL PANELS NOT SHOWN FOR CLARITY. SEE ITS, ILLUMINATION AND FIRE PROTECTION SYSTEM PLANS FOR JUNCTION BOX AND CONTROL PANEL LOCATIONS.

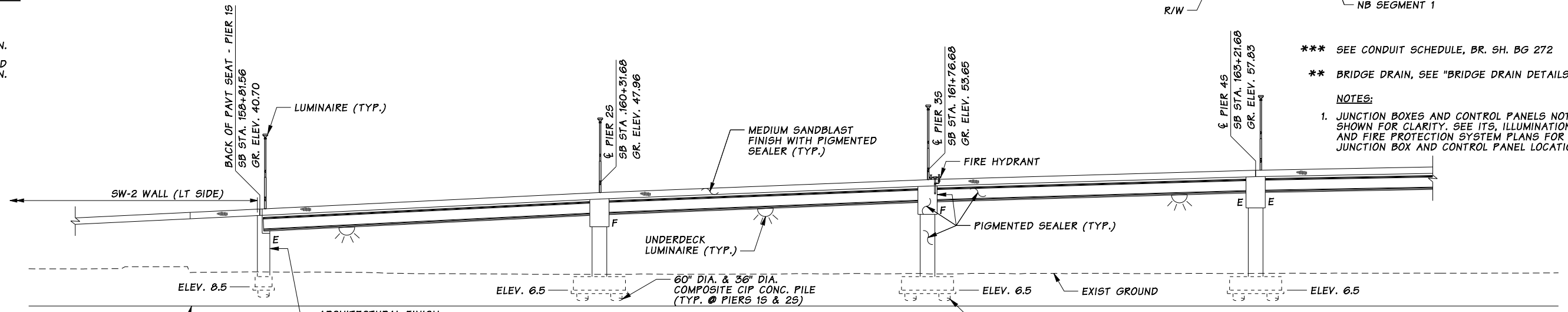

ELEVATION
GRADE ELEVATIONS SHOWN ARE FINISH GRADES AT TOP OF ROADWAY ON SB LINE AND ARE EQUAL TO PROFILE GRADE

**P.C. GIRDERS (WF74G-WF100G)
CONT. FOR LL, LOADING: HL-93**

SR 99 FILE NO. SHEET BG003

Bridge Design Engr.	Khaleghi, B	c:\aawork\pwwork\law\evans\dms081801\160073-S00-SBBG001.DLV	
Supervisor	Moore, TM	REGION NO.	STATE
Designed By	Lee, Chyuan-Shen	10	WASH.
Checked By	Mizumori, A	JOB NUMBER	
Detailed By	Evans, A	09A803	
Bridge Projects Engr.		DATE	REVISION
Prelim. Plan By		2/17/10	REVISED SHEET
Architect/Specialist			

FED. AID. PROJ. NO.	SHEET NO.	TOTAL SHEETS
DATE	REVISION	BY

BRIDGE AND STRUCTURES OFFICE



**SR 99
ALASKAN WAY VIADUCT - REPLACEMENT
S HOLGATE ST TO S KING ST - STAGE 2
BRIDGE NO. 99/540 NB & SB**
LAYOUT 1

BRIDGE SHEET NO. BG003
SHEET 849 OF 1475 SHEETS

SEC. 7, T.24N., R.4E., W.M. & SEC. 6, T.24N., R.4E., W.M.

SR 99

CITY OF SEATTLE

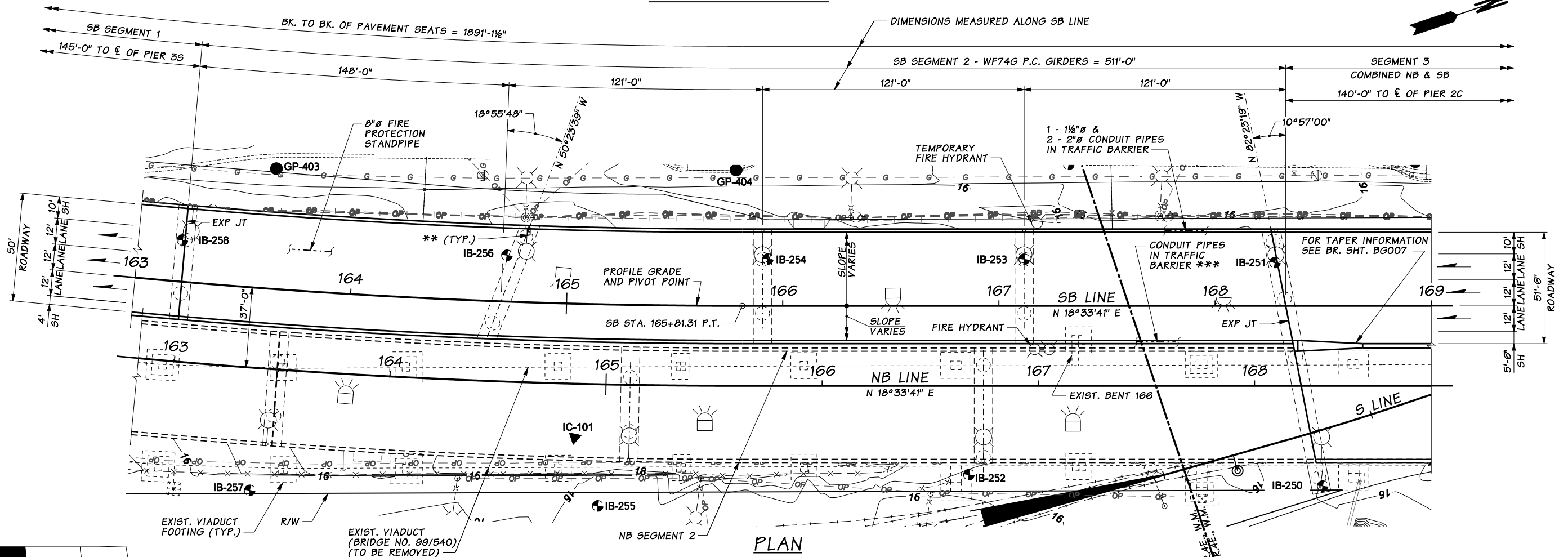

PLAN
BEARING OF ALL PIERS ARE NORMAL TO SB LINE UNLESS OTHERWISE NOTED

- BORING NUMBER AND APPROXIMATE LOCATION.
 - CONE PENETRATION TEST NUMBER AND APPROXIMATE LOCATION.
 - GEOPROBE NUMBER AND APPROXIMATE LOCATION.
 - LUMINAIRE
 - BRIDGE DRAIN
 - UNDERDECK LUMINAIRE
 - FIRE HYDRANT
- DATUM**
NAVD 1988

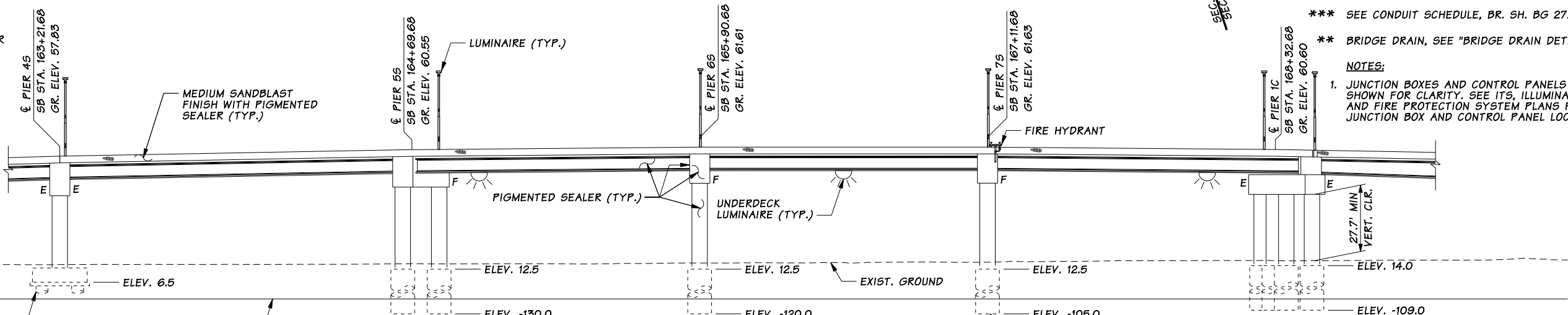

ELEVATION
GRADE ELEVATIONS SHOWN ARE FINISH GRADES AT TOP OF ROADWAY ON SB LINE AND ARE EQUAL TO PROFILE GRADE

P.C. GIRDERS (WF74G-WF100G)
CONT. FOR LL, LOADING: HL-93

- *** SEE CONDUIT SCHEDULE, BR. SH. BG 272
- ** BRIDGE DRAIN, SEE "BRIDGE DRAIN DETAILS".
- NOTES:**
- JUNCTION BOXES AND CONTROL PANELS NOT SHOWN FOR CLARITY. SEE ITS, ILLUMINATION AND FIRE PROTECTION SYSTEM PLANS FOR JUNCTION BOX AND CONTROL PANEL LOCATIONS.

SR 99 FILE NO. SHEET BG004

Bridge Design Engr.	Khaleghi, B	c:\aawork\pwwork\law\evans\dms08180160073-S00-SBBG002.DLV	
Supervisor	Moore, TM	REGION NO.	STATE
Designed By	Lee, Chyuan-Shen	10	WASH.
Checked By	Mizumori, A	JOB NUMBER	
Detailed By	Evans, A	09A803	
Bridge Projects Engr.		DATE	REVISION
Prelim. Plan By	2/17/10	REVISED SHEET	AM TMM
Architect/Specialist		DATE	REVISION
		BY	APPD

FED. AID. PROJ. NO.	SHEET NO.	TOTAL SHEETS

BRIDGE AND STRUCTURES OFFICE



SR 99
ALASKAN WAY VIADUCT - REPLACEMENT
S HOLGATE ST TO S KING ST - STAGE 2
BRIDGE NO. 99/540 NB & SB

LAYOUT 2

BRIDGE SHEET NO. BG004
SHEET 850 OF 1475 SHEETS

C.S. 1791 PROJ. NO. XL3237A UCO REGION ~ SR 99 ~ S HOLGATE ST TO S KING ST ~ BRIDGE NO. 99/540 NB & SB REPLACEMENT

SEC. 7, T.24N., R.4E., W.M.
CITY OF SEATTLE

SR 99

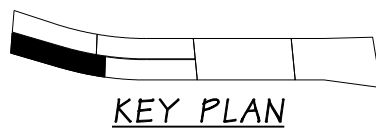
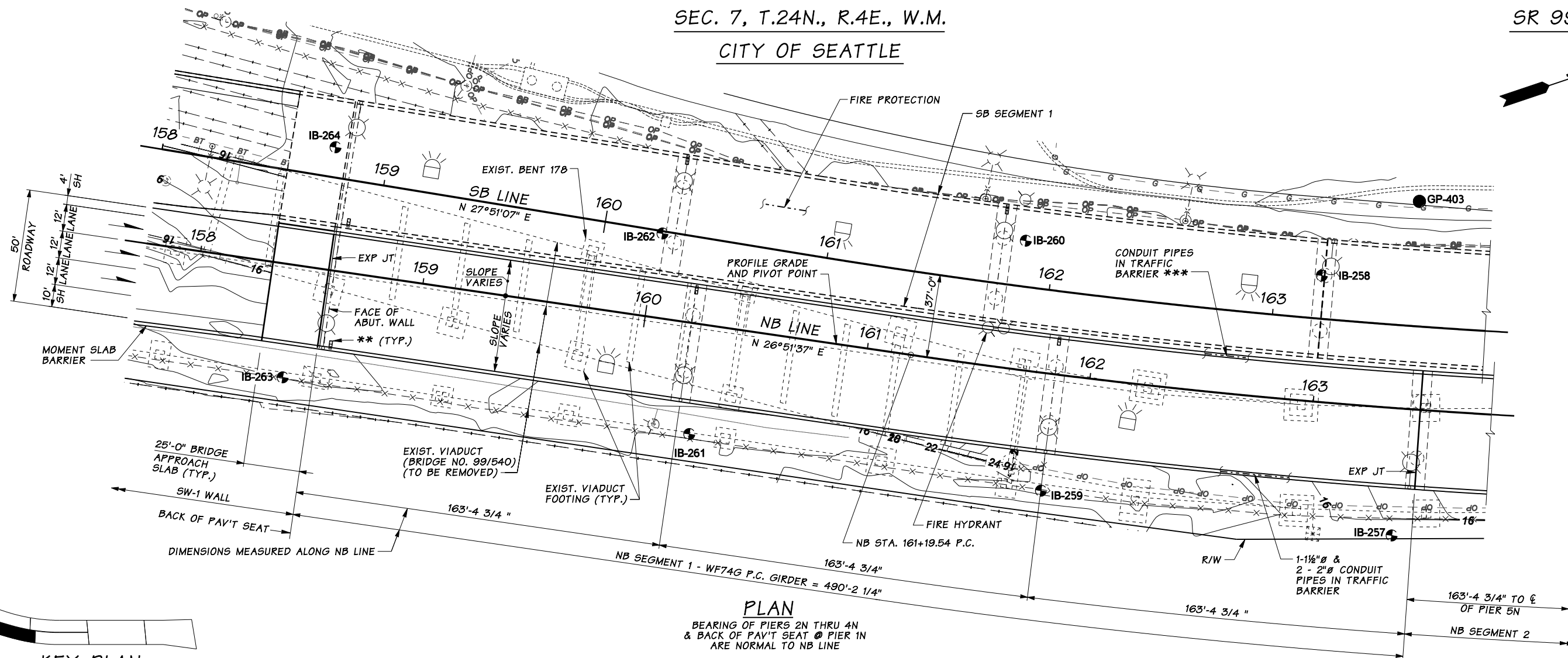

- BORING NUMBER AND APPROXIMATE LOCATION.
- GEOPROBE NUMBER AND APPROXIMATE LOCATION.
- LUMINAIRE
- BRIDGE DRAIN
- UNDERDECK LUMINAIRE
- FIRE HYDRANT

*** SEE CONDUIT SCHEDULE, BR. SH. BG 272
** BRIDGE DRAIN, SEE "BRIDGE DRAIN DETAILS".

NOTES:
1. JUNCTION BOXES AND CONTROL PANELS NOT SHOWN FOR CLARITY. SEE ITS, ILLUMINATION AND FIRE PROTECTION SYSTEM PLANS FOR JUNCTION BOX AND CONTROL PANEL LOCATIONS.

DATUM
NAVD 1988

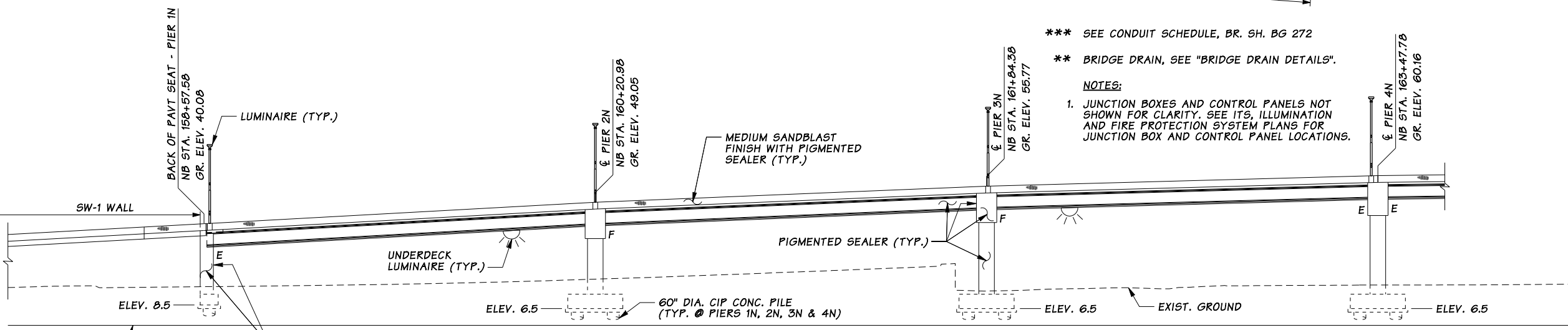

**P.C. GIRDERS (WF74G-WF100G)
CONT. FOR LL, LOADING: HL-93**

SR 99 FILE NO. SHEET_BG005

Bridge Design Engr.	Khaleghi, B	c:\aawork\pwwork\law\evans\dms081801\160073-S00-SBBG003.DLV
Supervisor	Moore, TM	
Designed By	Lee, Chyuan-Shen	10/08
Checked By	Mizumori, A	09/09
Detailed By	Evans, A	10/08
Bridge Projects Engr.		
Prelim. Plan By	2/17/10	REVISED SHEET
Architect/Specialist	DATE	REVISION
	BY	AM TMM
		APPD

REGION NO.	STATE	FED. AID. PROJ. NO.	SHEET NO.	TOTAL SHEETS
10	WASH.			
JOB NUMBER				
09A803				

BRIDGE AND STRUCTURES OFFICE

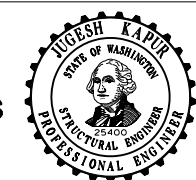

**SR 99
ALASKAN WAY VIADUCT - REPLACEMENT
S HOLGATE ST TO S KING ST - STAGE 2
BRIDGE NO. 99/540 NB & SB**

LAYOUT 3

BRIDGE SHEET NO. BG005
SHEET 851 OF 1475 SHEETS

C.S. 1791 PROJ. NO. XL3237A UCO REGION ~ SR 99 ~ S HOLGATE ST TO S KING ST ~ BRIDGE NO. 99/540 NB & SB REPLACEMENT

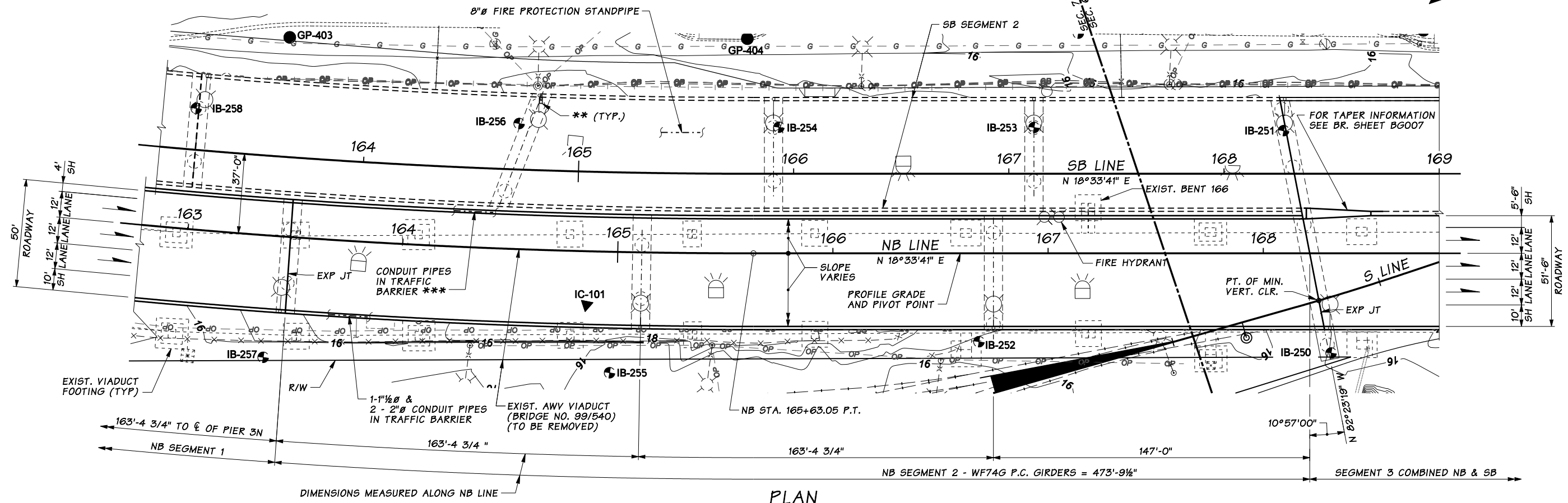

PLAN

BEARING OF PIERS ARE NORMAL TO NB LINE UNLESS OTHERWISE NOTED



KEY PLAN

- BORING NUMBER AND APPROXIMATE LOCATION.
- CONE PENETRATION TEST NUMBER AND APPROXIMATE LOCATION.
- GEOPROBE NUMBER AND APPROXIMATE LOCATION.
- LUMINAIRE
- BRIDGE DRAIN
- UNDERDECK LUMINAIRE
- FIRE HYDRANT

DATUM
NAVD 1988

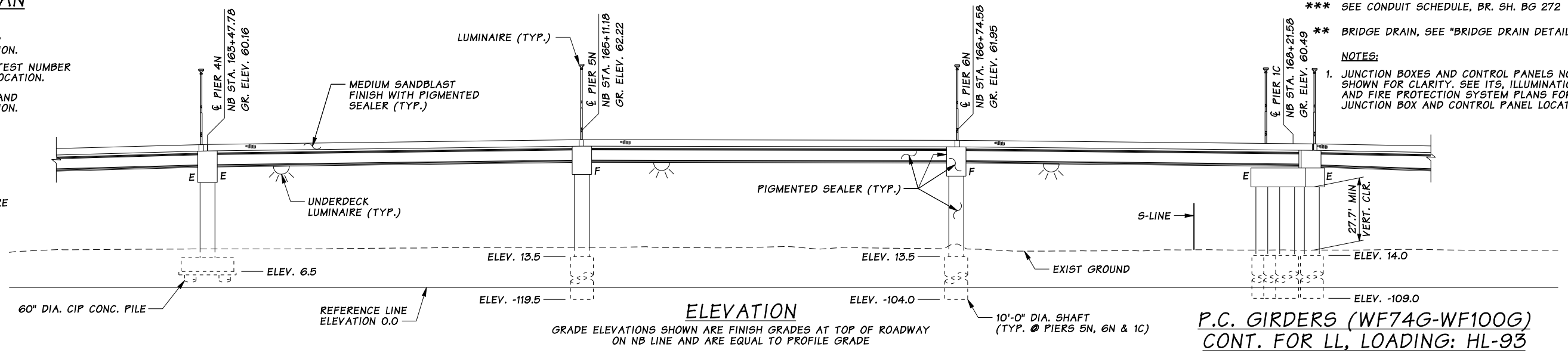

ELEVATION

GRADE ELEVATIONS SHOWN ARE FINISH GRADES AT TOP OF ROADWAY ON NB LINE AND ARE EQUAL TO PROFILE GRADE

- *** SEE CONDUIT SCHEDULE, BR. SH. BG 272
- ** BRIDGE DRAIN, SEE "BRIDGE DRAIN DETAILS".
- NOTES:**
- 1. JUNCTION BOXES AND CONTROL PANELS NOT SHOWN FOR CLARITY. SEE ITS, ILLUMINATION AND FIRE PROTECTION SYSTEM PLANS FOR JUNCTION BOX AND CONTROL PANEL LOCATIONS.

P.C. GIRDERS (WF74G-WF100G)
CONT. FOR LL, LOADING: HL-93

SR 99 FILE NO. SHEET_BG006

Bridge Design Engr.	Khaleghi, B	c:\aawork\pwwork\law\evans\dms081801\160073-S00-SBBG004.DLV	
Supervisor	Moore, TM	REGION NO.	STATE
Designed By	Lee, Chyuan-Shen	10	WASH.
Checked By	Mizumori, A	JOB NUMBER	
Detailed By	Evans, A	09A803	
Bridge Projects Engr.		DATE	REVISION
Prelim. Plan By		2/17/10	REVISED SHEET
Architect/Specialist			

FED. AID. PROJ. NO.	SHEET NO.	TOTAL SHEETS
BY	APPD	

BRIDGE AND STRUCTURES OFFICE



SR 99
ALASKAN WAY VIADUCT - REPLACEMENT
S HOLGATE ST TO S KING ST - STAGE 2
BRIDGE NO. 99/540 NB & SB
LAYOUT 4

BRIDGE SHEET NO.	BG006
SHEET OF	852 OF 1475
SHEETS	

C.S. 1791 PROJ. NO. XL3237A UCO REGION ~ SR 99 ~ S HOLGATE ST TO S KING ST ~ BRIDGE NO. 99/540 NB & SB REPLACEMENT

SEC. 6, T.24N., R.4E., W.M.
CITY OF SEATTLE

SR 99

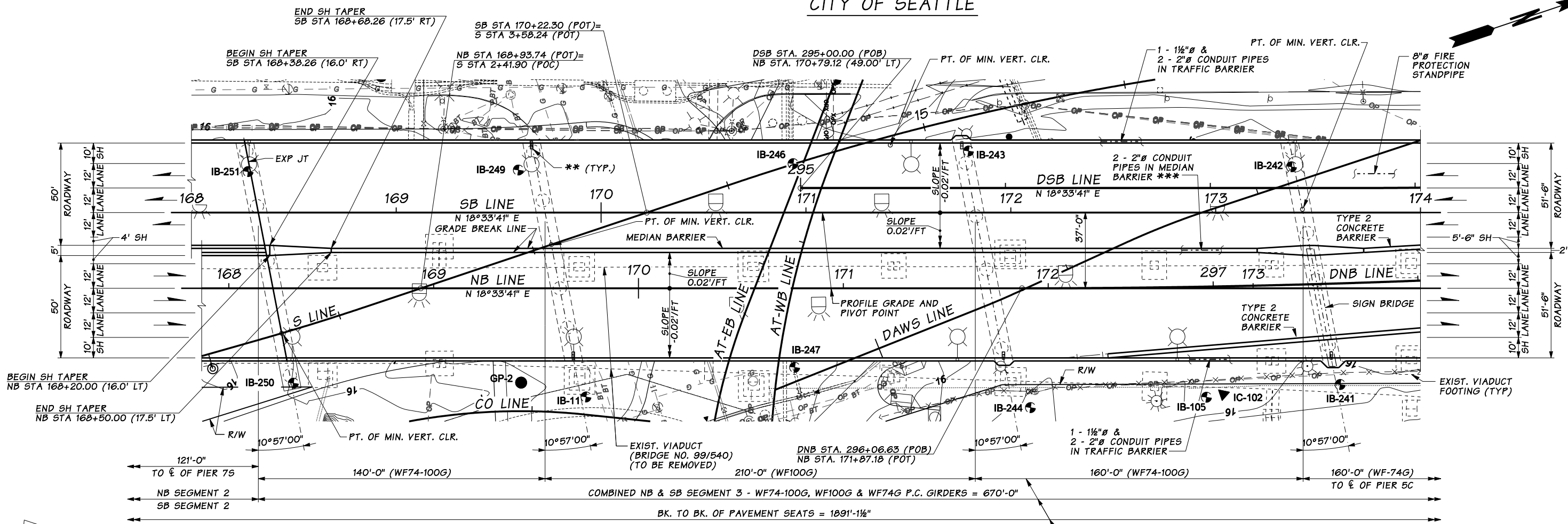

PLAN

BEARING OF ALL PIERS ARE
N 82°23'19" W

DIMENSIONS MEASURED ALONG SB LINE



KEY PLAN

- BORING NUMBER AND APPROXIMATE LOCATION.
- CONE PENETRATION TEST NUMBER AND APPROXIMATE LOCATION.
- GEOPROBE NUMBER AND APPROXIMATE LOCATION.
- LUMINAIRE
- BRIDGE DRAIN
- UNDERDECK LUMINAIRE
- FIRE HYDRANT

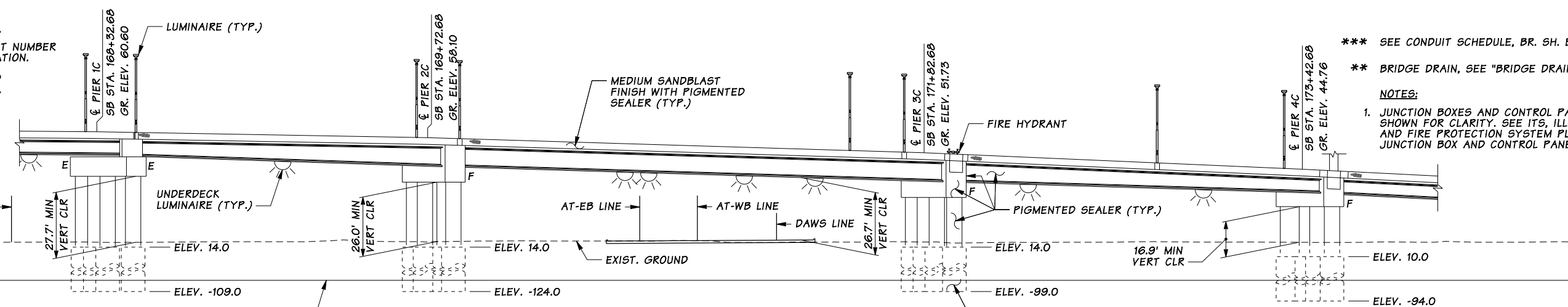

ELEVATION

GRADE ELEVATIONS SHOWN ARE FINISH GRADES AT TOP OF ROADWAY ON SB LINE AND ARE EQUAL TO PROFILE GRADE

P.C. GIRDERS (WF74G-WF100G)
CONT. FOR LL, LOADING: HL-93

- *** SEE CONDUIT SCHEDULE, BR. SH. BG272
- ** BRIDGE DRAIN, SEE "BRIDGE DRAIN DETAILS".
- NOTES:
- 1. JUNCTION BOXES AND CONTROL PANELS NOT SHOWN FOR CLARITY. SEE ITS, ILLUMINATION AND FIRE PROTECTION SYSTEM PLANS FOR JUNCTION BOX AND CONTROL PANEL LOCATIONS.

SR 99 FILE NO. SHEET BG007

Bridge Design Engr.	Khaleghi, B	c:\aawork\pwwork\law\evans\adms08180160073-S00-SBBG005.DLV
Supervisor	Moore, TM	
Designed By	Mizumori, A	10/08
Checked By	Lee, Chyuan-Shen	09/09
Detailed By	Evans, A	10/08
Bridge Projects Engr.		
Prelim. Plan By	2/17/10	REVISED SHEET
Architect/Specialist	DATE	REVISION

REGION NO.	STATE	FED. AID. PROJ. NO.	SHEET NO.	TOTAL SHEETS
10	WASH.			
JOB NUMBER		09A803		

BRIDGE AND STRUCTURES OFFICE



SR 99
ALASKAN WAY VIADUCT - REPLACEMENT
S HOLGATE ST TO S KING ST - STAGE 2
BRIDGE NO. 99/540 NB & SB

LAYOUT 5

BRIDGE SHEET NO.	BG007
SHEET	853
OF	1475
SHEETS	

C.S. 1791 PROJ. NO. XL3237A UCO REGION - SR 99 - S HOLGATE ST TO S KING ST - BRIDGE NO. 99/540 NB & SB REPLACEMENT

SEC. 6, T.24N., R.4E., W.M.

CITY OF SEATTLE

SR 99

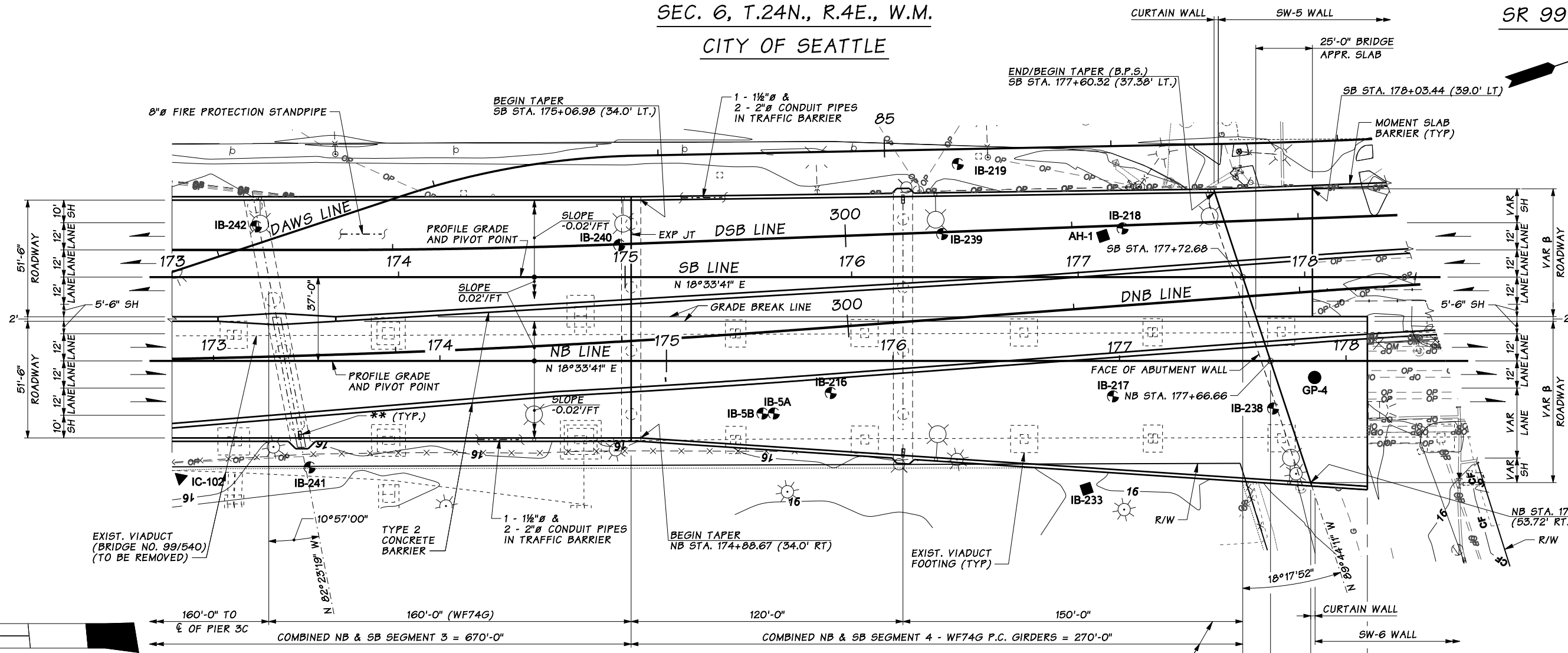

KEY PLAN

PLAN

BEARING OF ALL PIERS ARE NORMAL TO SB LINE UNLESS OTHERWISE NOTED

DIMENSIONS MEASURED ALONG SB LINE

- BORING NUMBER AND APPROXIMATE LOCATION.
- SONIC CORE BORING TEST NUMBER AND APPROXIMATE LOCATION.
- CONE PENETRATION TEST NUMBER AND APPROXIMATE LOCATION.
- GEOPROBE NUMBER AND APPROXIMATE LOCATION.
- LUMINAIRE
- BRIDGE DRAIN
- FIRE HYDRANT

β SEE CIVIL PLANS FOR RDWY. CHANNELIZATION AT END OF CONTRACT

** BRIDGE DRAIN, SEE "BRIDGE DRAIN DETAILS".

NOTES:
1. JUNCTION BOXES AND CONTROL PANELS NOT SHOWN FOR CLARITY. SEE ITS, ILLUMINATION AND FIRE PROTECTION SYSTEM PLANS FOR JUNCTION BOX AND CONTROL PANEL LOCATIONS.

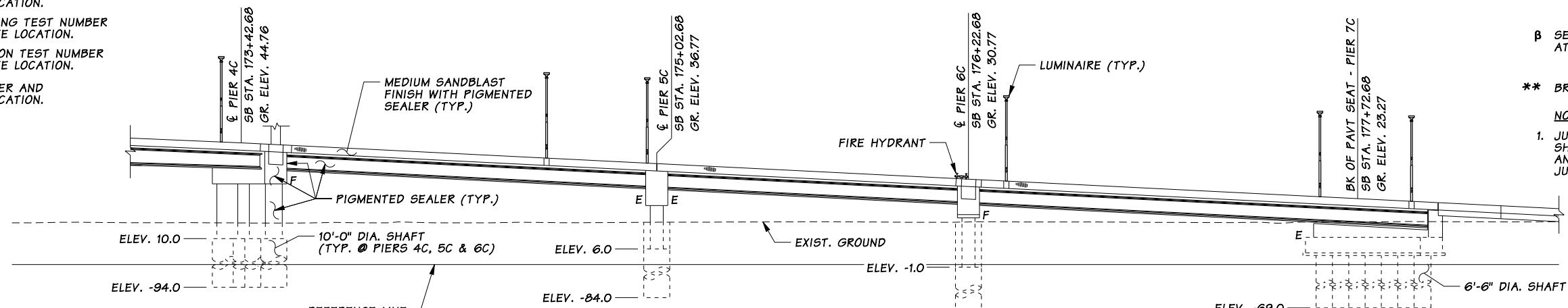

ELEVATION

GRADE ELEVATIONS SHOWN ARE FINISH GRADES AT TOP OF ROADWAY ON SB LINE AND ARE EQUAL TO PROFILE GRADE

P.C. GIRDERS (WF74G-WF100G)
CONT. FOR LL, LOADING: HL-93

DATUM
NAVD 1988

Bridge Design Engr.	Khaleghi, B	c:\aawork\pwwork\law\evans\dms08180160073-S00-SBBG006.DLV	
Supervisor	Moore, TM	REGION NO.	STATE
Designed By	Mizumori, A	10	WASH.
Checked By	Lee, Chyuan-Shen	JOB NUMBER	
Detailed By	Evans, A	09A803	
Bridge Projects Engr.		DATE	REVISION
Prelim. Plan By		2/17/10	REVISED SHEET
Architect/Specialist		DATE	REVISION
		BY	AM TMM
			APPD

BRIDGE AND STRUCTURES OFFICE



SR 99
ALASKAN WAY VIADUCT - REPLACEMENT
S HOLGATE ST TO S KING ST - STAGE 2
BRIDGE NO. 99/540 NB & SB

LAYOUT 6

BRIDGE SHEET NO.	BG008
SHEET OF	854 OF 1475
SHEETS	

SK 99 FILE NO. SHEET BG008

C.S. 1791 PROJ. NO. XL3237A UCO REGION - SR 99 - S HOLGATE ST TO S KING ST - BRIDGE NO. 99/540 NB & SB REPLACEMENT

GENERAL NOTES

1. ALL MATERIAL AND WORKMANSHIP SHALL BE IN ACCORDANCE WITH THE REQUIREMENTS OF THE WASHINGTON STATE DEPARTMENT OF TRANSPORTATION STANDARD SPECIFICATIONS FOR ROAD, BRIDGE AND MUNICIPAL CONSTRUCTION DATED 2008, AND AMENDMENTS.
 2. THIS STRUCTURE HAS BEEN DESIGNED IN ACCORDANCE WITH THE REQUIREMENTS OF THE AASHTO LRFD BRIDGE DESIGN SPECIFICATIONS 4TH EDITION AND INTERIMS THROUGH 2008. THE SEISMIC DESIGN OF THIS STRUCTURE HAS BEEN COMPLETED IN ACCORDANCE WITH THE REQUIREMENTS OF THE AASHTO GUIDE SPECIFICATIONS FOR LRFD SEISMIC BRIDGE DESIGN 1ST EDITION USING SEISMIC DESIGN CATEGORY D, SITE CLASS F, AND SITE-SPECIFIC RESPONSE SPECTRA. DEAD LOAD INCLUDES ADDITIONAL FUTURE WEARING SURFACE OF 25 POUNDS PER SQUARE FOOT.
 3. THE CONCRETE IN THE BRIDGE DECK SHALL BE CLASS 4000D. THE CONCRETE IN SHAFTS (PILES) SHALL BE CLASS 4000P. CONCRETE IN THE SEALS SHALL BE CLASS 4000W. CONCRETE IN THE APPROACH SLABS SHALL BE CLASS 4000A. ALL OTHER CAST-IN-PLACE CONCRETE SHALL BE CLASS 4000.
 4. THE BACKFILL BEHIND THE ABUTMENTS MAY BE PLACED PRIOR TO PLACEMENT OF THE SUPERSTRUCTURE.
 5. UNLESS OTHERWISE SHOWN IN THE PLANS, CONCRETE COVER MEASURED FROM THE FACE OF THE CONCRETE TO THE FACE OF ANY REINFORCING STEEL SHALL BE 2½" AT THE TOP OF THE BRIDGE DECK, 1" AT THE BOTTOM OF THE BRIDGE DECK, 3" AT THE BOTTOM OF FOOTING (SHAFT/PILE CAP), 2" AT THE TOP OF FOOTING (SHAFT/PILE CAP) AND 1½" AT ALL OTHER LOCATIONS.
 6. FALSEWORK SHALL BE CAREFULLY RELEASED TO PREVENT IMPACT OR UNDUE STRESS IN THE STRUCTURE.
 7. CONDUITS, JUNCTION BOXES, AND UTILITIES ARE SHOWN FOR REFERENCE ONLY. THE CONTRACTOR SHALL COORDINATE THESE PLANS WITH THE FIRE PROTECTION SYSTEM, ELECTRICAL, I.T.S. AND OTHER CIVIL PLANS.
 8. EXISTING FEATURES AND DIMENSIONS ARE BASED ON INSPECTION REPORTS AND AS-BUILT PLANS. ALL DIMENSIONS NOTED WITH AN ASTERISK (*) SHALL BE FIELD MEASURED BY THE CONTRACTOR PRIOR TO ORDERING MATERIALS AND PROCEEDING WITH CONSTRUCTION.
 9. THE CONCRETE SEALS ARE DESIGNED FOR A SEAL VENT ELEVATION OF 10.0. AFTER THE SEALS ARE PLACED, COFFERDAMS SHALL NOT BE DEWATERED WHEN THE WATER SURFACE IS ABOVE THE DESIGN ELEVATION. PROVISIONS SHALL BE MADE TO FLOOD THE COFFERDAM IN THE EVENT THAT THE WATER SURFACE RISES ABOVE THE DESIGN ELEVATION. IF, IN THE OPINION OF THE ENGINEER, WATER CONDITIONS AT THE TIME OF CONSTRUCTION DO NOT REQUIRE SEALS FOR SHAFT/PILE CAP CONSTRUCTION, THE ENGINEER MAY DELETE THE SEALS, AND EXCAVATION SHALL PROCEED ONLY TO THE BOTTOM OF THE SHAFT/PILE CAP.
10. NOMINAL SHAFT CAPACITY SHALL BE TAKEN AS FOLLOWS:

SERVICE LIMIT STATE		
PIER NO.	SKIN FRICTION CAPACITY	END BEARING CAPACITY
5N	3900 KIPS	1250 KIPS
6N	3750 KIPS	2400 KIPS
5S	5000 KIPS	2950 KIPS
6S	4600 KIPS	2300 KIPS
7S	3750 KIPS	2400 KIPS
1C	5850 KIPS	3100 KIPS
2C	8600 KIPS	2700 KIPS
3C	6000 KIPS	3050 KIPS
4C	4700 KIPS	3650 KIPS
5C	3600 KIPS	3900 KIPS
6C	5600 KIPS	3850 KIPS
7C	2050 KIPS	1500 KIPS

10. (CONTINUED)



STRENGTH LIMIT STATE AND EXTREME EVENT LIMIT STATE W/O LIQUEFACTION		
PIER NO.	SKIN FRICTION CAPACITY	END BEARING CAPACITY
5N	3900 KIPS	4800 KIPS
6N	3750 KIPS	4650 KIPS
5S	5000 KIPS	5800 KIPS
6S	4600 KIPS	4500 KIPS
7S	3750 KIPS	4650 KIPS
1C	5850 KIPS	6250 KIPS
2C	8600 KIPS	5500 KIPS
3C	6000 KIPS	6300 KIPS
4C	4700 KIPS	7350 KIPS
5C	3600 KIPS	7800 KIPS
6C	5600 KIPS	7900 KIPS
7C	2050 KIPS	2350 KIPS

EXTREME EVENT LIMIT STATE WITH LIQUEFACTION		
PIER NO.	SKIN FRICTION CAPACITY	END BEARING CAPACITY
5N	1600 KIPS	4800 KIPS
6N	1650 KIPS	4650 KIPS
5S	2600 KIPS	5800 KIPS
6S	1900 KIPS	4500 KIPS
7S	1650 KIPS	4650 KIPS
1C	4050 KIPS	6250 KIPS
2C	7200 KIPS	5500 KIPS
3C	4600 KIPS	6300 KIPS
4C	3350 KIPS	7350 KIPS
5C	2650 KIPS	7800 KIPS
6C	4600 KIPS	7900 KIPS
7C	1450 KIPS	2350 KIPS

11. PILES SHALL BE DRIVEN TO AN ULTIMATE RESISTANCE AS FOLLOWS:

ULTIMATE BEARING RESISTANCE		
PIER NO.	36" DIA.	60" DIA.
1N	NA	1480 TONS
2N	NA	1590 TONS
3N	NA	1620 TONS
4N	NA	1420 TONS
1S	1480 TONS	940 TONS
2S	1420 TONS	580 TONS
3S	NA	1650 TONS
4S	NA	1420 TONS

LEGEND

-  IDENTIFIES SECTION, VIEW OR DETAIL
-  TAKEN OR SHOWN ON BRIDGE SHEET 15
-  TAKEN OR SHOWN ON THE SAME SHEET

SR 99 FILE NO. SHEET BG009

Bridge Design Engr. Khaleghi, B	M:\Y-Team\AWV SOUTH INTERCHANGE\window files\GENERAL NOTES.WND			
Supervisor Moore, TM				
Designed By Lee, CS	09/08			
Checked By Mizumori, A	09/09			
Detailed By Hanson, CE	09/08			
Bridge Projects Engr.				
Prelim. Plan By	2/17/10	REVISED SHEET	CSL	TMM
Architect/Specialist	DATE	REVISION	BY	APPD



BRIDGE AND STRUCTURES OFFICE



**SR 99
ALASKAN WAY VIADUCT - REPLACEMENT
S HOLGATE ST TO S KING ST - PHASE 2
BRIDGE NO. 99/540 NB & SB**

GENERAL NOTES

BRIDGE SHEET NO. **BG009**
SHEET OF **855**
1475 SHEETS

CURVE DATA					
P.I. STATION	DELTA	RADIUS	TANGENT	LENGTH	BACK TANGENT BEARING
SB STA. 163+36.60	09°17'25" LT.	3025.00'	245.79'	490.49'	N 27°51'07" E
NB STA. 163+41.68	08°17'56" LT.	3062.00'	222.14'	443.51'	N 26°51'37" E

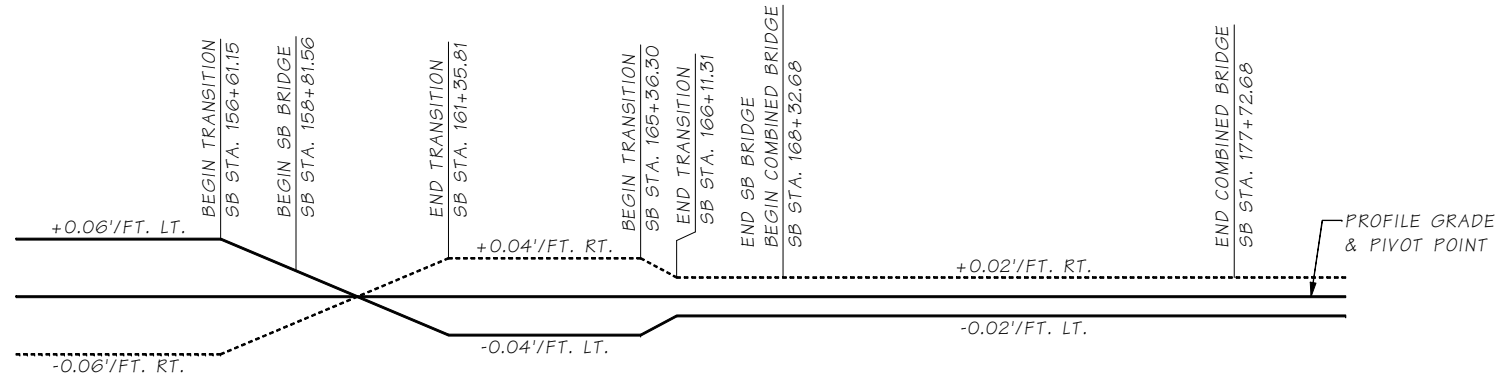

SB LINE SUPERELEVATION DIAGRAM

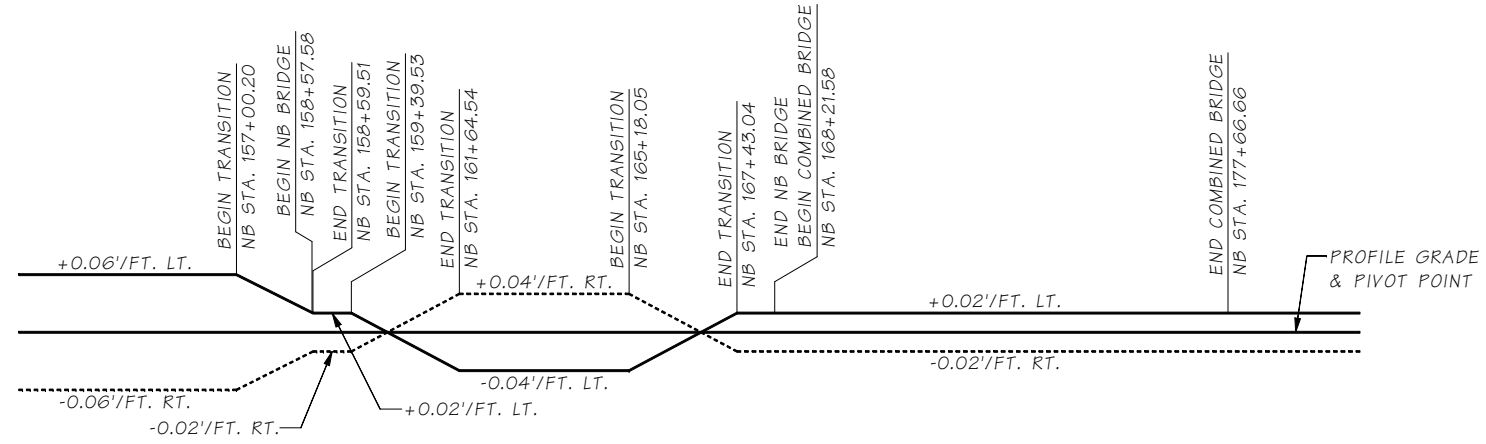

NB LINE SUPERELEVATION DIAGRAM

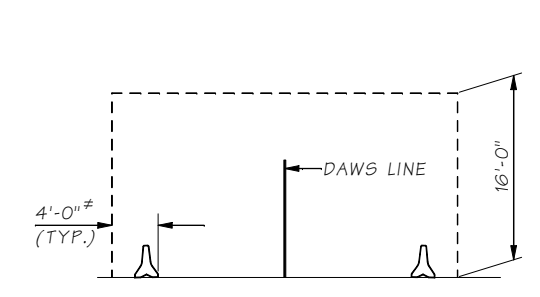

TEMPORARY FALSEWORK OPENING

* EXCEPT AT COLUMNS 3C & 4A, SEE PAVING DETAILS

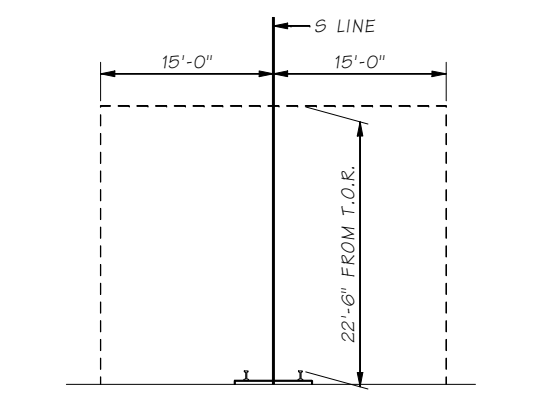

TEMPORARY FALSEWORK OPENING

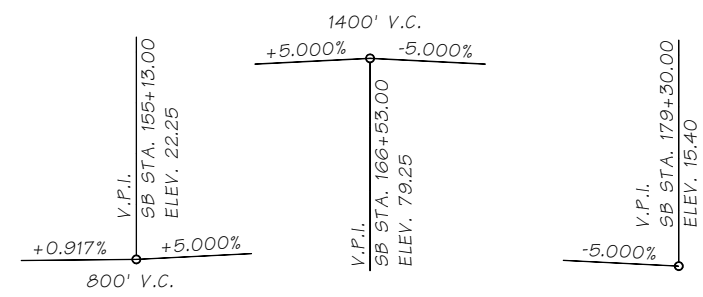

SB LINE PROFILES

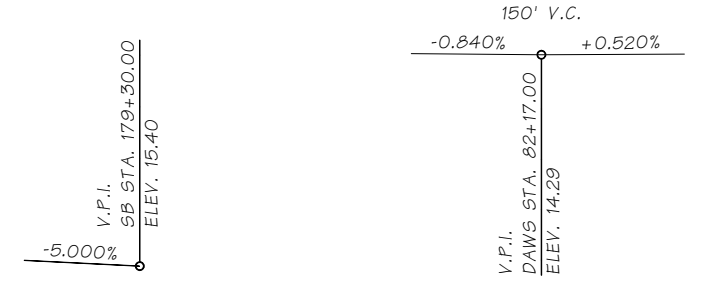

DAWS LINE PROFILE

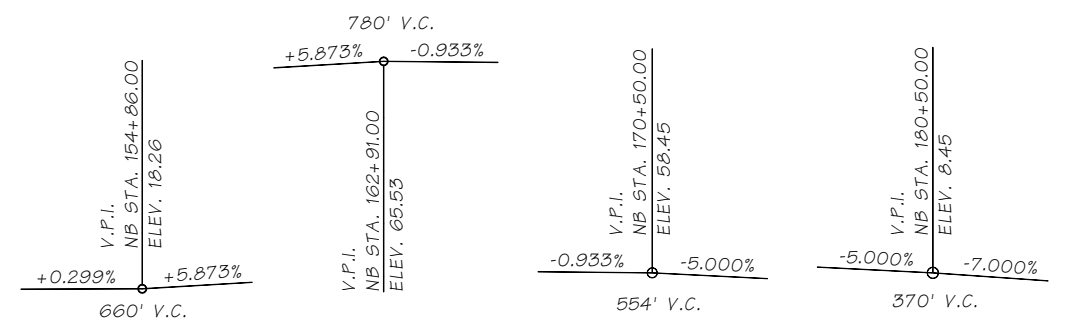

NB LINE PROFILES

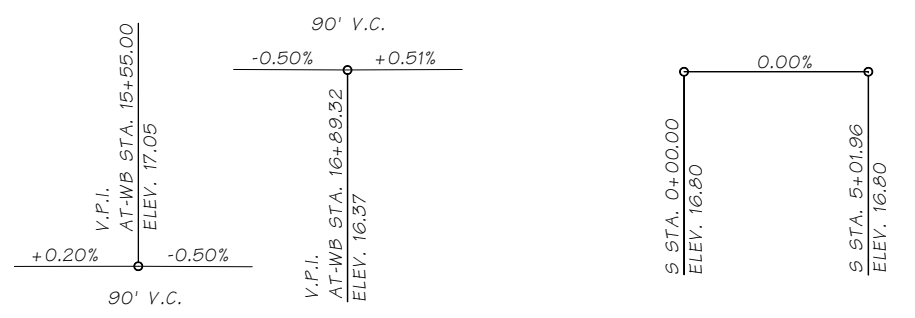

AT-WB LINE PROFILES

S LINE PROFILE

SR 99 FILE NO. SHEET BG010

Bridge Design Engr. Khaleghi, B	M:\Y-Team\AWV SOUTH INTERCHANGE\window files\Geometric Data.WND	REGION NO.	STATE	FED. AID PROJ. NO.	SHEET NO.	TOTAL SHEETS
Supervisor Moore, TM		10	WASH.			
Designed By Lee, CS	10/08	JOB NUMBER 09A803				
Checked By Mizumori, A	09/09					
Detailed By Hanson, CE	10/08					
Bridge Projects Engr.						
Prelim. Plan By	2/17/10	REVISED SHEET	AM	TMM		
Architect/Specialist	DATE	REVISION	BY	APPD		



BRIDGE AND STRUCTURES OFFICE

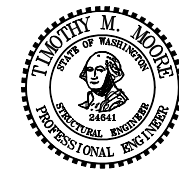

SR 99
ALASKAN WAY VIADUCT - REPLACEMENT
S HOLGATE ST TO S KING ST - PHASE 2
BRIDGE NO. 99/540 NB & SB

GEOMETRIC DATA

BRIDGE SHEET NO. BG010
SHEET 856 OF 1475 SHEETS

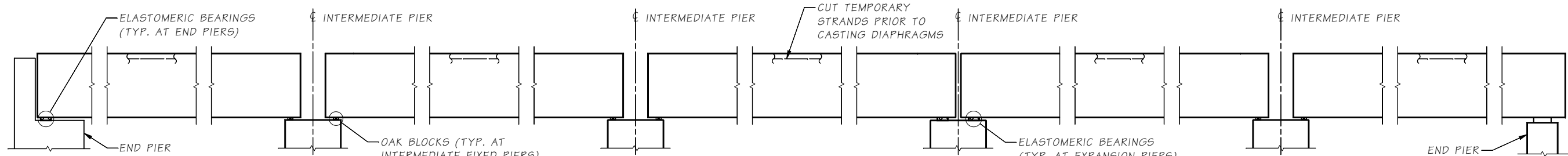

STAGE 1 ~ SET GIRDERS IN PLACE

THE CONTRACTOR SHALL PROVIDE ADEQUATE BRACING TO ENSURE THE STABILITY OF GIRDERS LONGITUDINALLY AND TRANSVERSELY. GROUT TEMPORARY STRAND RECESSES AFTER CUTTING.

NOTE:
GIRDERS SHALL NOT BE PLACED ON PIERS AND CROSSBEAMS UNTIL THE CONCRETE COMPRESSIVE STRENGTH IN PIERS AND CROSSBEAMS HAS REACHED 4000 PSI.

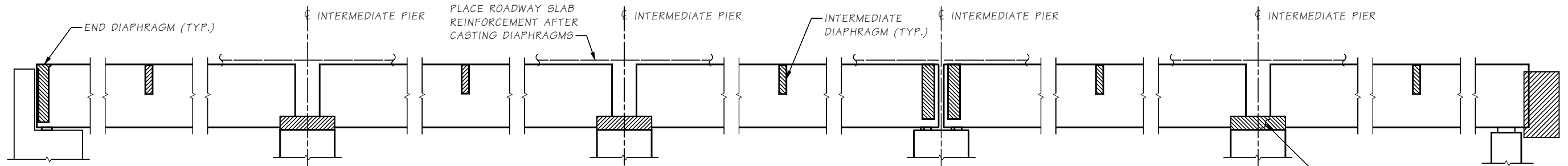

STAGE 2 ~ CAST DIAPHRAGMS AND PLACE ROADWAY SLAB REINFORCEMENT

BOTTOM PORTION OF PIER DIAPHRAGM SHALL NOT BE CAST UNTIL 30 DAYS (MIN.) AFTER GIRDER FABRICATION.

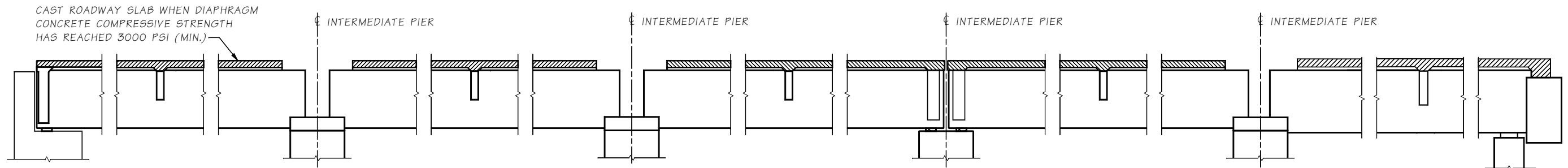

STAGE 3 ~ CAST ROADWAY SLAB

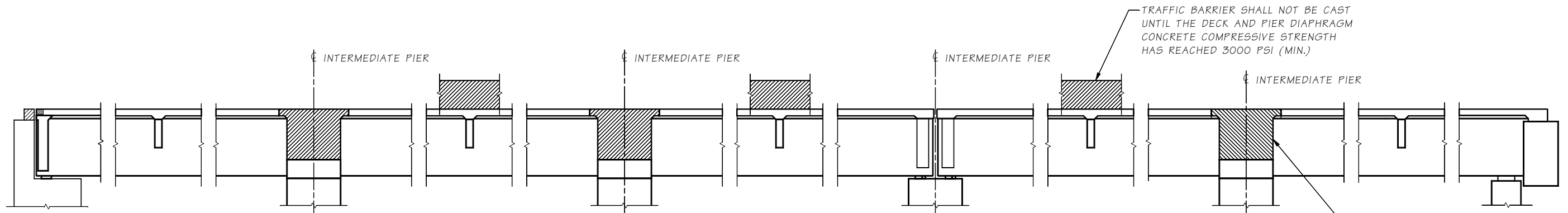

STAGE 4 ~ COMPLETE DIAPHRAGMS

NOTE:
NO LIVE LOAD SHALL BE ALLOWED ON THE SPANS UNTIL THE TOP PORTION OF THE PIER DIAPHRAGM CONCRETE COMPRESSIVE STRENGTH HAS REACHED 3000 PSI (MIN.).

CONSTRUCTION SEQUENCE ~ SUPERSTRUCTURE

SR 99 FILE NO. SHEET BG011

Bridge Design Engr.	Khaleghi, B	M:\Y-Team\AWV SOUTH INTERCHANGE\window files\Const Sequence.WND				REGION NO.	STATE	FED. AID PROJ. NO.	SHEET NO.	TOTAL SHEETS
Supervisor	Moore, TM					10	WASH.			
Designed By	Lee, CS	10/08								
Checked By	Mizumori, A	09/09								
Detailed By	Hanson, CE	10/08								
Bridge Projects Engr.						JOB NUMBER				
Prelim. Plan By						09A803				
Architect/Specialist		DATE	REVISION	BY	APPD					



BRIDGE AND STRUCTURES OFFICE

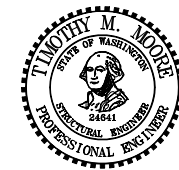

SR 99
ALASKAN WAY VIADUCT - REPLACEMENT
S HOLGATE ST TO S KING ST - PHASE 2
BRIDGE NO. 99/540 NB & SB

CONSTRUCTION SEQUENCE

BRIDGE SHEET NO. BG011
SHEET 857 OF 1475 SHEETS

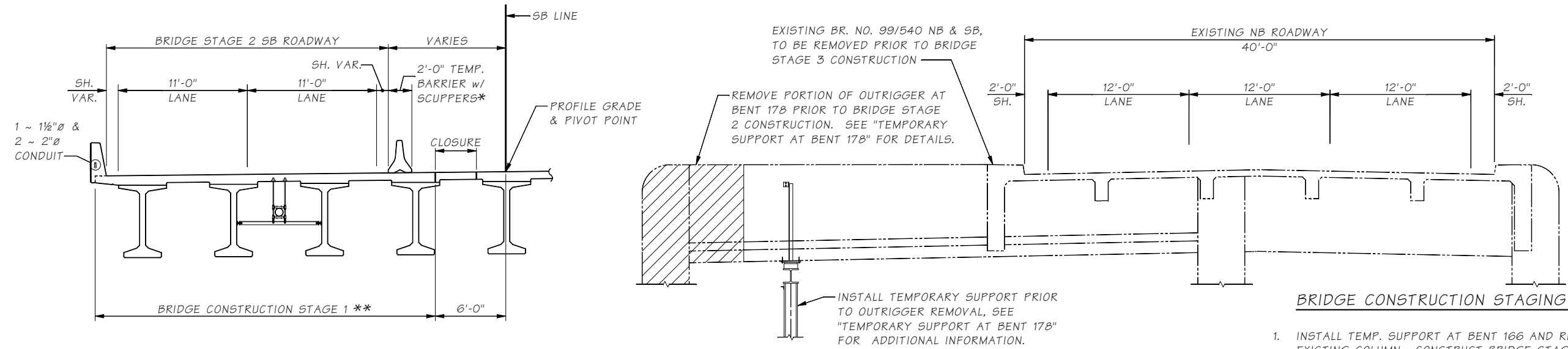

CONSTRUCTION STAGING ~ NB & SB STRUCTURES

SPAN 15 SHOWN, SPANS 25 & 35 SIMILAR.
 * FOR TEMPORARY CONCRETE BARRIER ANCHORING, SEE STD. PLAN K-80.35-00.
 ** SPANS 45 - 75 ARE BUILT FULL WIDTH DURING BRIDGE STAGE 1.

BRIDGE CONSTRUCTION STAGING NOTES

1. INSTALL TEMP. SUPPORT AT BENT 166 AND REMOVE PORTION OF EXISTING COLUMN. CONSTRUCT BRIDGE STAGE 1 SOUTHBOUND SUBSTRUCTURE. INTERMEDIATE PIER FOOTINGS, SHAFTS, COLUMNS AND CROSSBEAM SHALL BE CONSTRUCTED IN ONE STAGE.
2. CONSTRUCT BRIDGE STAGE 1 SUPERSTRUCTURE AND INSTALL TEMPORARY BARRIERS, SEE "CONSTRUCTION SEQUENCE" FOR DETAILS. CONTRACTOR MAY SET BRIDGE STAGE 2 GIRDERS, PLACE BOTTOM PORTION OF PIER DIAPHRAGM CONCRETE, CAST INTERMEDIATE DIAPHRAGM AND END DIAPHRAGM CONCRETE TO EDGE OF CLOSURE IN SPANS 25 AND 35 DURING BRIDGE STAGE 1 CONSTRUCTION.
3. MOVE SOUTHBOUND SR 99 TRAFFIC FROM EXISTING VIADUCT TO NEWLY CONSTRUCTED BRIDGE STAGE 1 SB STRUCTURE AFTER THE TRAFFIC BARRIER CONCRETE COMPRESSIVE STRENGTH HAS REACHED 3000 PSI (MIN).
4. INSTALL TEMPORARY SUPPORT AT EXISTING BRIDGE OUTRIGGER BENT 178, SEE "TEMPORARY SUPPORT AT BENT 178" FOR DETAILS.
5. REMOVE PORTION OF OUTRIGGER AT EXISTING BRIDGE BENT 178.
6. CONSTRUCT BRIDGE STAGE 2 ABUTMENT AND SET STAGE 2 PRECAST GIRDERS.
7. CAST BOTTOM PORTION OF PIER DIAPHRAGMS.
8. CAST INTERMEDIATE DIAPHRAGMS AND END DIAPHRAGMS TO EDGE OF CLOSURE.
9. CAST ROADWAY DECK CONCRETE TO EDGE OF CLOSURE WHEN DIAPHRAGM CONCRETE STRENGTH HAS REACHED 3000 PSI (MIN).
10. PLACE INTERMEDIATE DIAPHRAGM, END DIAPHRAGM AND SLAB CLOSURES 24 HOURS MINIMUM AFTER PLACING ROADWAY DECK CONCRETE.
11. PLACE TOP PORTION OF PIER DIAPHRAGM 10 DAYS MINIMUM AFTER PLACEMENT OF BRIDGE STAGE 2 ROADWAY DECK CONCRETE.
12. MOVE NORTHBOUND SR 99 TRAFFIC FROM EXISTING VIADUCT TO NEWLY CONSTRUCTED SB STRUCTURE AFTER THE BRIDGE STAGE 2 TRAFFIC BARRIER CONCRETE COMPRESSIVE STRENGTH HAS REACHED 3000 PSI (MIN).
13. DEMOLISH EXISTING VIADUCT.
14. CONSTRUCT NB STRUCTURE, (BRIDGE CONSTRUCTION STAGE 3).
15. REMOVE TEMPORARY BARRIERS AND MOVE TRAFFIC ONTO NEWLY FINISHED STRUCTURES.

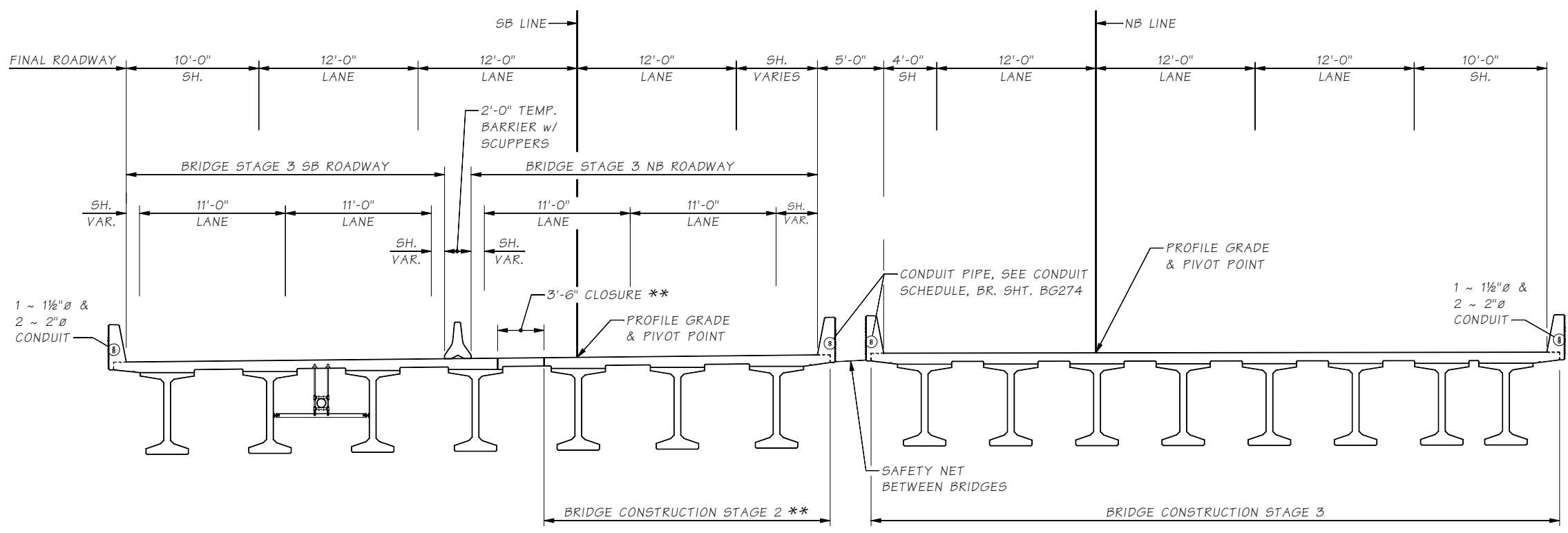

CONSTRUCTION STAGING ~ NB & SB STRUCTURES

** SPANS 15, 25 AND 35 ONLY. SPANS 45 - 75 ARE BUILT FULL WIDTH DURING BRIDGE STAGE 1.

SR 99 FILE NO. SHEET BG012

Bridge Design Engr.	Khaleghi, B	M:\Y-Team\AW SOUTH INTERCHANGE\window files\CONSTR STAGING SEQ 1.WND			
Supervisor	Moore, TM	REGION NO.	STATE	FED. AID PROJ. NO.	SHEET NO.
Designed By	Lee, CS 10/08	10	WASH.		TOTAL SHEETS
Checked By	Mizumori, A 09/09	JOB NUMBER 09A803			
Detailed By	Hanson, CE 10/08				
Bridge Projects Engr.					
Prelim. Plan By					
Architect/Specialist		DATE	REVISION	BY	APPD



BRIDGE AND STRUCTURES OFFICE

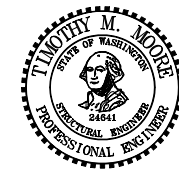

SR 99
ALASKAN WAY VIADUCT - REPLACEMENT
S HOLGATE ST TO S KING ST - PHASE 2
 BRIDGE NO. 99/540 NB & SB
 CONSTRUCTION STAGING
 DETAILS 1 OF 2

BRIDGE SHEET NO. BG012
 SHEET 858 OF 1475 SHEETS

BRIDGE CONSTRUCTION STAGING NOTES

1. CONSTRUCT BRIDGE STAGE 1 COMBINED STRUCTURE SUBSTRUCTURE.
2. CONSTRUCT BRIDGE STAGE 1 SUPERSTRUCTURE TO LIMIT OF STAGE 1 CONSTRUCTION AND INSTALL TEMPORARY BARRIERS, SEE "CONSTRUCTION SEQUENCE" FOR DETAILS.
3. MOVE SOUTHBOUND SR 99 TRAFFIC FROM EXISTING VIADUCT TO NEWLY CONSTRUCTED BRIDGE STAGE 1 COMBINED STRUCTURE AFTER THE TRAFFIC BARRIER CONCRETE COMPRESSIVE STRENGTH HAS REACHED 3000 PSI (MIN).
4. MOVE NORTHBOUND SR 99 TRAFFIC FROM EXISTING VIADUCT TO BRIDGE STAGE 1 COMBINED STRUCTURE AFTER THE BRIDGE STAGE 2 SOUTHBOUND STRUCTURE TRAFFIC BARRIER CONCRETE COMPRESSIVE STRENGTH HAS REACHED 3000 PSI (MIN).
5. DEMOLISH THE EXISTING VIADUCT
6. CONSTRUCT BRIDGE STAGE 3 COMBINED STRUCTURE SUBSTRUCTURE.
7. SET STAGE 3 PRECAST GIRDERS.
8. CAST BOTTOM PORTION OF BRIDGE STAGE 3 PIER DIAPHRAGMS.
9. CAST INTERMEDIATE DIAPHRAGMS AND END DIAPHRAGMS TO EDGE OF CLOSURE.
10. CAST BRIDGE STAGE 3 ROADWAY DECK CONCRETE TO EDGE OF CLOSURE WHEN DIAPHRAGM CONCRETE STRENGTH HAS REACHED 3000 PSI (MIN).
11. PLACE INTERMEDIATE DIAPHRAGM, END DIAPHRAGM AND SLAB CLOSURES 24 HOURS MINIMUM AFTER PLACING ROADWAY DECK CONCRETE.
12. PLACE TOP PORTION OF PIER DIAPHRAGMS 10 DAYS MINIMUM AFTER PLACEMENT OF BRIDGE STAGE 3 ROADWAY DECK CONCRETE.
13. CAST/PLACE MEDIAN BARRIERS AFTER DECK AND PIER DIAPHRAGM CONCRETE COMPRESSIVE STRENGTH HAS REACHED 3000 PSI (MIN).
14. REMOVE TEMPORARY BARRIERS, THEN MOVE TRAFFIC TO FULL COMBINED STRUCTURE.

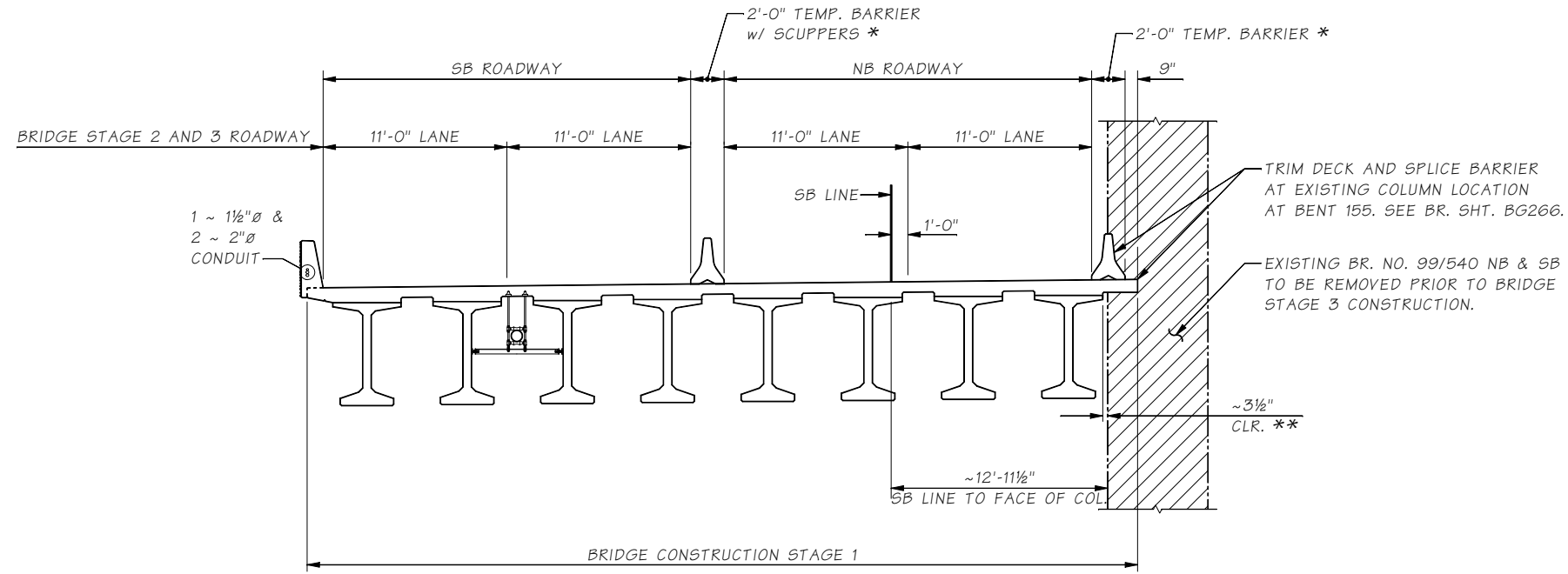

CONSTRUCTION STAGING ~ COMBINED NB/SB STRUCTURE

SPANS 1C - 4C SHOWN, SPANS 5C & 6C SIMILAR.
 * FOR TEMPORARY CONCRETE BARRIER ANCHORING, SEE STD. PLAN K-80.35-00.
 ** EXISTING COLUMN SHOWN IN SPAN 4C.

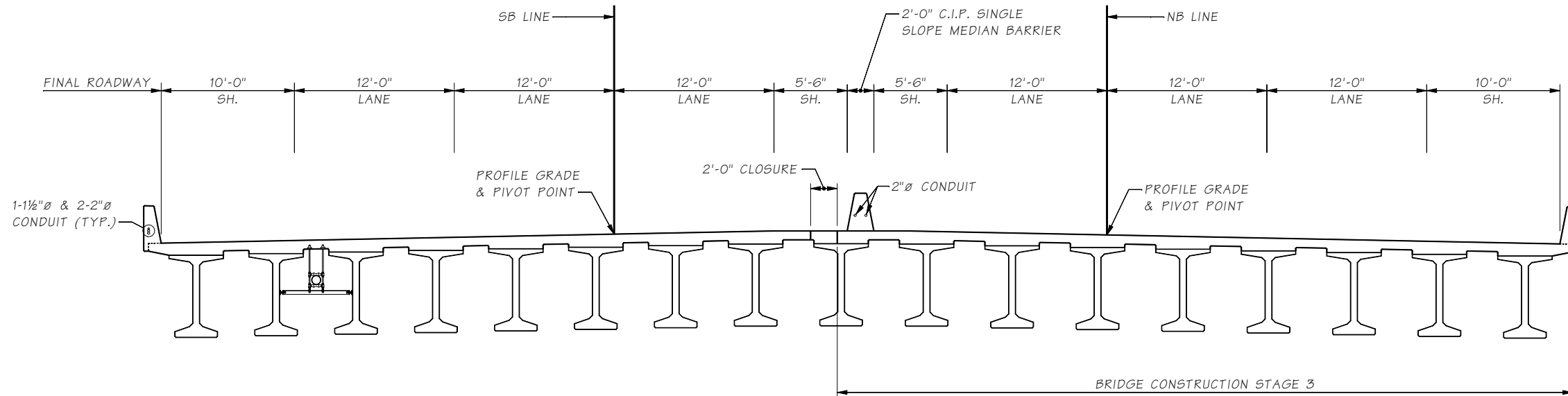

CONSTRUCTION STAGING ~ COMBINED NB/SB STRUCTURE

SPANS 1C-4C SHOWN, SPANS 5C & 6C SIMILAR.
 NOTE: EXTERIOR SHOULDER WIDTHS VARY IN SPANS 5C & 6C.

SR 99 FILE NO. SHEET BG013

Bridge Design Engr.	Khaleghi, B	M:\Y-Team\AWV SOUTH INTERCHANGE\window files\CONSTR STAGING SEQ 2.WND			
Supervisor	Moore, TM	REGION NO.	STATE	FED. AID PROJ. NO.	SHEET NO.
Designed By	Mizumori, A 10/08	10	WASH.		TOTAL SHEETS
Checked By	Lee, CS 09/09				
Detailed By	Hanson, CE 10/08				
Bridge Projects Engr.		JOB NUMBER			
Prelim. Plan By		09A803			
Architect/Specialist	DATE	REVISION	BY	APPD	



BRIDGE AND STRUCTURES OFFICE

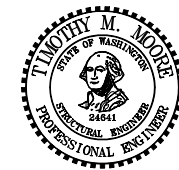

SR 99
ALASKAN WAY VIADUCT - REPLACEMENT
S HOLGATE ST TO S KING ST - PHASE 2
 BRIDGE NO. 99/540 NB & SB

CONSTRUCTION STAGING
 DETAILS 2 OF 2

BRIDGE SHEET NO. BG013
 SHEET 859 OF 1475 SHEETS

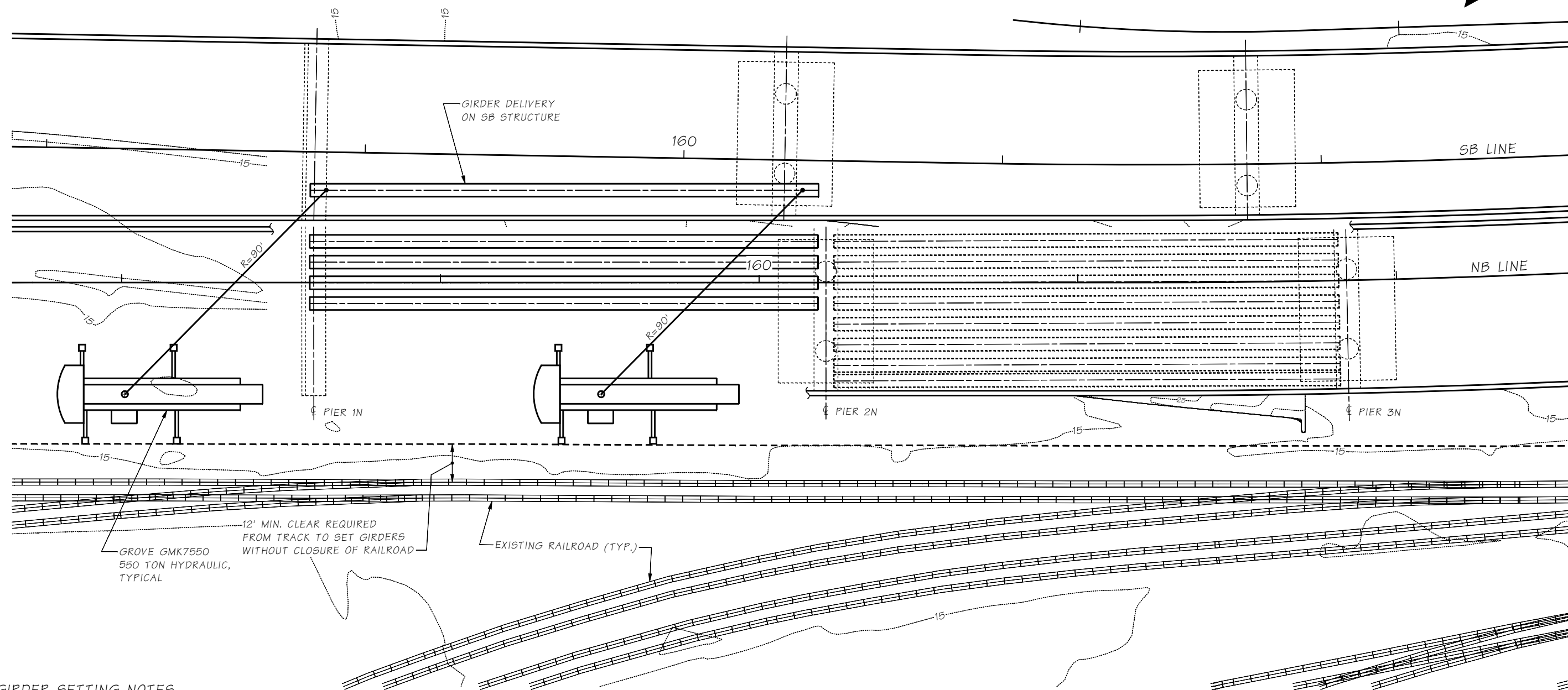
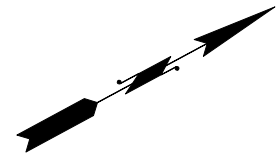

GIRDER SETTING NOTES

1. CONTRACTOR TO SET AS MANY GIRDERS AS POSSIBLE IN PHASE 1 TO MINIMIZE THE NUMBER OF RAILROAD CLOSURES.
2. CRANES IDENTIFIED ARE FOR ILLUSTRATION PURPOSES ONLY. THE CONTRACTOR IS FULLY RESPONSIBLE FOR SELECTING, LOCATING AND OPERATING CRANES IN SUCH A MANNER TO SAFELY PICK AND SET GIRDERS.
3. DELIVERY SYSTEM OF NEW GIRDERS SHALL MEET ALL APPLICABLE SHIPPING REGULATIONS.
4. PROTECTION OF RAILROAD TRACKS FOR CRANE SUPPORT WILL BE PERFORMED BY THE RAILROAD. THE CONTRACTOR SHALL COORDINATE WITH THE RAILROAD PER THE REQUIREMENTS OF THE SPECIAL PROVISIONS.

**PLAN
CONSTRUCTION SEQUENCE 3 ~ PHASE 1**

NB STA. 160+21 TO NB STA. 161+84
SETTING AS MANY GIRDERS WITHOUT RAILROAD CLOSURE.

SR 99 FILE NO. SHEET BG014

Bridge Design Engr.	Khaleghi, B	M:\Y-Team\AWV SOUTH INTERCHANGE\window files\Crane Location 1.WND			
Supervisor	Moore, TM	REGION NO.	STATE	FED. AID PROJ. NO.	SHEET NO.
Designed By	Moore, TM	10	WASH.		TOTAL SHEETS
Checked By	Lee, CS	JOB NUMBER			
Detailed By	Williams, M	09A803			
Bridge Projects Engr.		DATE	REVISION	BY	APPD
Prelim. Plan By					
Architect/Specialist					



BRIDGE AND STRUCTURES OFFICE



SR 99
ALASKAN WAY VIADUCT - REPLACEMENT
S HOLGATE ST TO S KING ST - PHASE 2
BRIDGE NO. 99/540 NB & SB

CRANE LOCATION FOR GIRDER PLACEMENT
PHASE 1

BRIDGE SHEET NO. BG014
SHEET 860 OF 1475 SHEETS

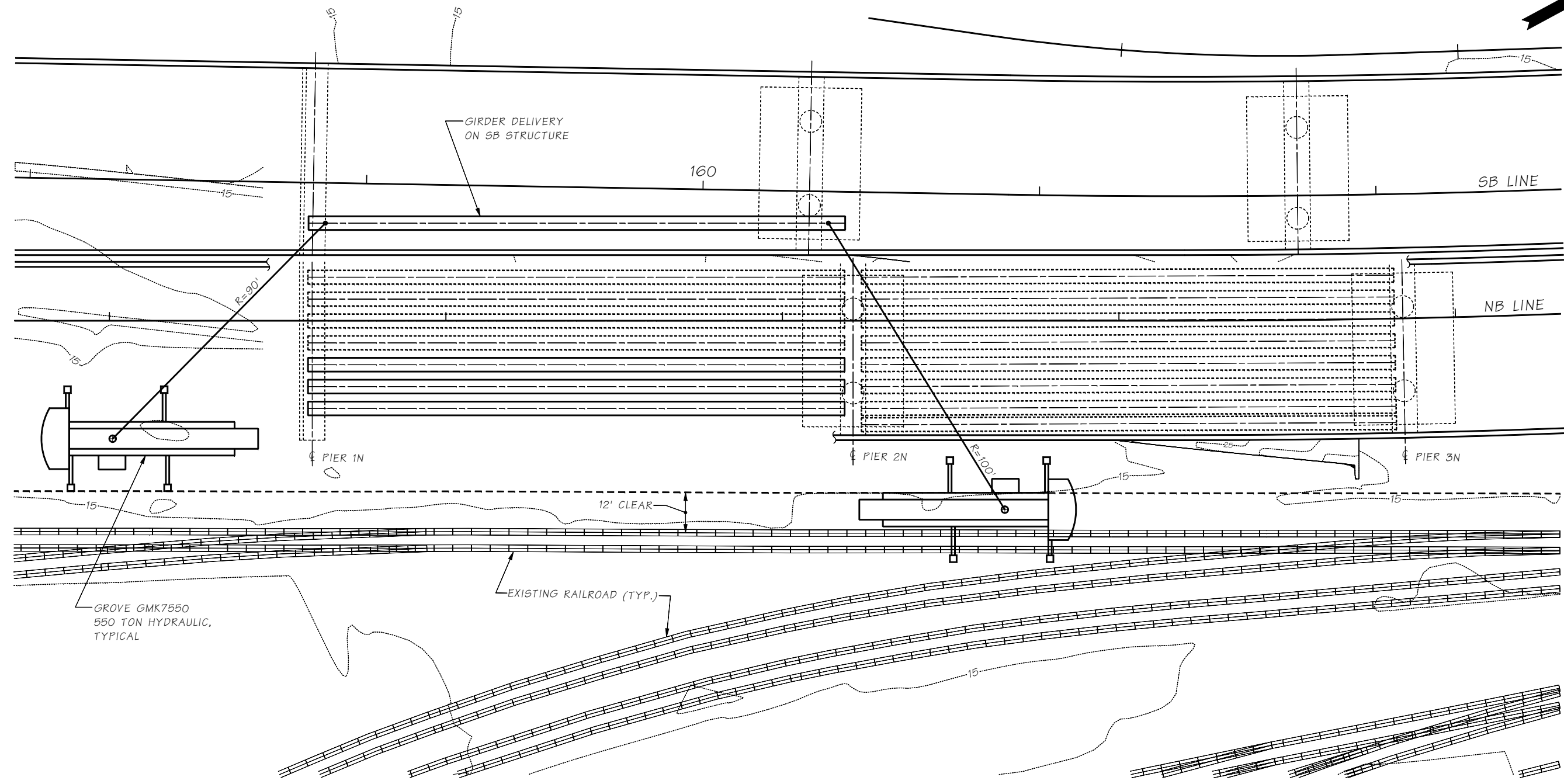
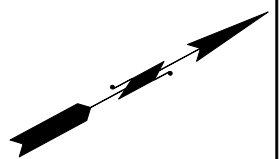

PLAN
CONSTRUCTION SEQUENCE 3 ~ PHASE 2

NB STA. 161+84 TO NB STA. 163+48
 SETTING REMAINING GIRDERS.

SR 99 FILE NO. SHEET BG015

Bridge Design Engr.	Khaleghi, B	M:\Y-Team\AW SOUTH INTERCHANGE\window files\Crane Location 2.WND			
Supervisor	Moore, TM				
Designed By	Moore, TM	05/09			
Checked By	Lee, CS	09/09			
Detailed By	Williams, M	05/09			
Bridge Projects Engr.					
Prelim. Plan By					
Architect/Specialist					
	DATE	REVISION	BY	APPD	



BRIDGE AND STRUCTURES OFFICE

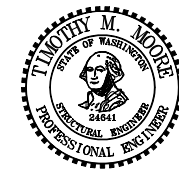

SR 99
ALASKAN WAY VIADUCT - REPLACEMENT
S HOLGATE ST TO S KING ST - PHASE 2
 BRIDGE NO. 99/540 NB & SB

CRANE LOCATION FOR GIRDER PLACEMENT
 PHASE 2

BRIDGE SHEET NO. BG015
 SHEET 861 OF 1475 SHEETS

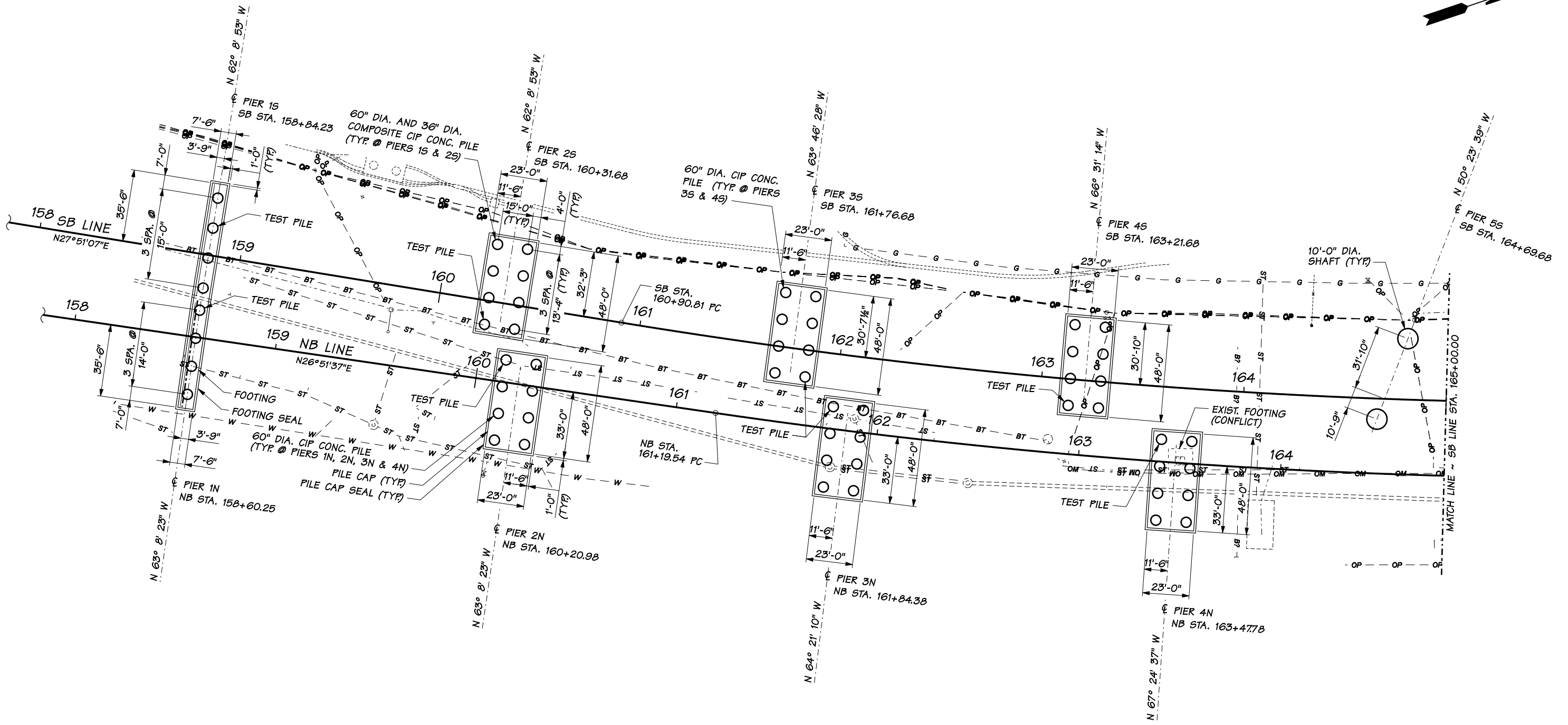
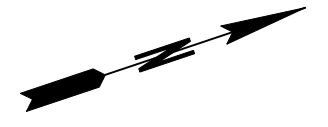

FOUNDATION LAYOUT
 WITH EXISTING UTILITIES, SEE UE SERIES
 SHEETS FOR COMPLETE UTILITY PLAN.

NOTE:
 TRANSVERSE DIMENSIONS ARE
 MEASURED ALONG & PIERS

SR 99 FILE NO. SHEET BG016

Bridge Design Engr.	Khaleghi, B	c:\aawork\pwwork\law\evans\dms08180160073-S00-SBBG101.DLV		REGION NO.	STATE	FED. AID. PROJ. NO.	SHEET NO.	TOTAL SHEETS
Supervisor	Moore, TM			10	WASH.			
Designed By	Mizumori, A	10/08						
Checked By	Lee, Chyuan-Shen	09/09						
Detailed By	Evans, A	10/08						
Bridge Projects Engr.								
Prelim. Plan By								
Architect/Specialist		DATE	REVISION	BY	APPD			

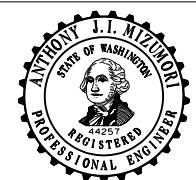

**BRIDGE
 AND
 STRUCTURES
 OFFICE**

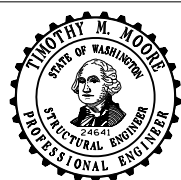

**SR 99
 ALASKAN WAY VIADUCT - REPLACEMENT
 S HOLGATE ST TO S KING ST - STAGE 2
 BRIDGE NO. 99/540 NB & SB**

FOUNDATION PLAN 1 OF 3

BRIDGE SHEET NO.
BG016
 SHEET
 862
 OF
 1475
 SHEETS

C.S. 1791 PROJ. NO. XL3237A UCO REGION ~ SR 99 ~ S HOLGATE ST TO S KING ST ~ BRIDGE NO. 99/540 NB & SB REPLACEMENT

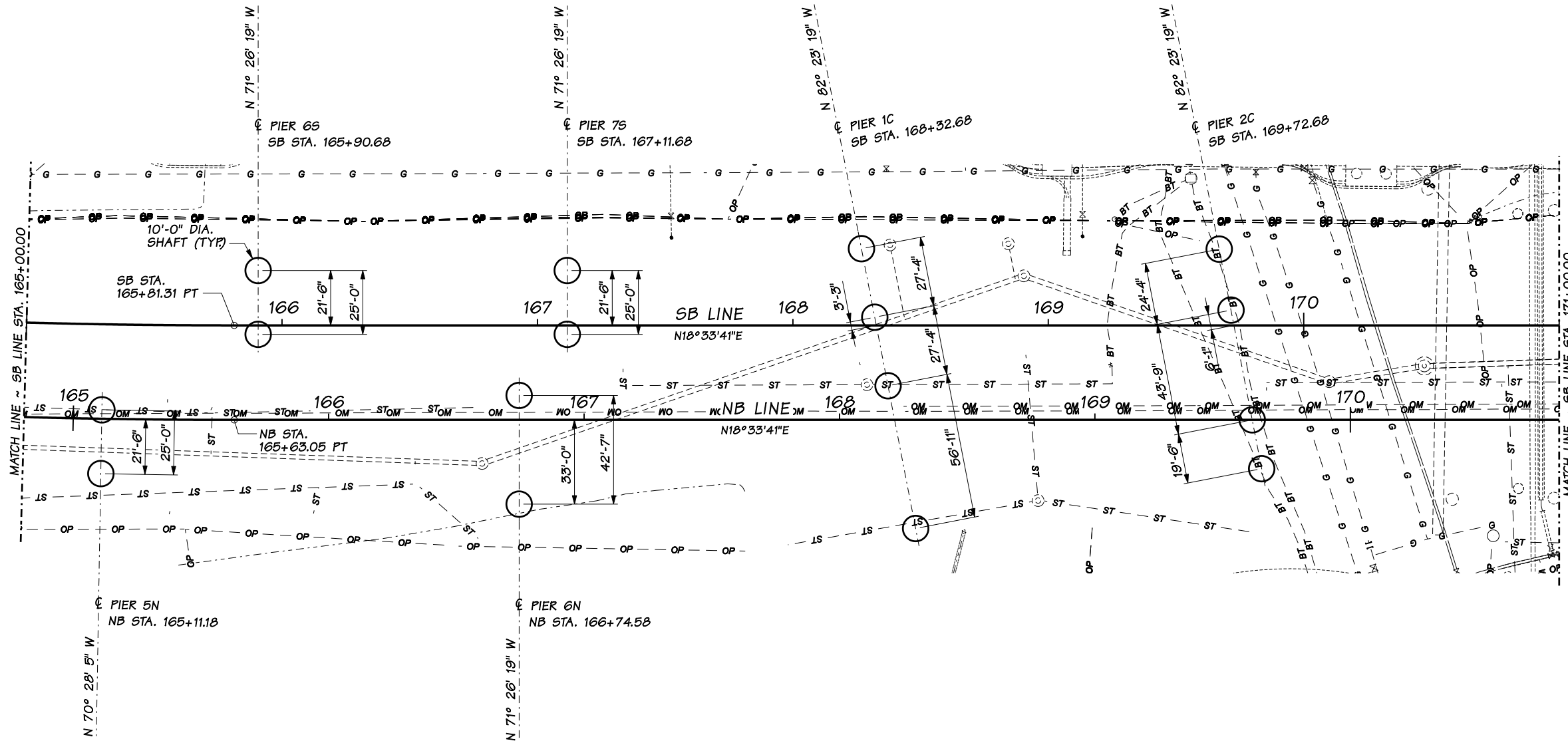

FOUNDATION LAYOUT

WITH EXISTING UTILITIES, SEE UE SERIES SHEETS FOR COMPLETE UTILITY PLAN.

NOTE:
TRANSVERSE DIMENSIONS ARE MEASURED ALONG & PIERS

SR 99 FILE NO. SHEET BGO17

Bridge Design Engr.	Khaleghi, B	c:\aawork\pwwork\law\levansa\dms081801\160073-S00-SBBG102.DLV	
Supervisor	Moore, TM	REGION NO.	STATE
Designed By	Mizumori, A	10	WASH.
Checked By	Lee, Chyuan-Shen	JOB NUMBER	
Detailed By	Evans, A	09A803	
Bridge Projects Engr.		DATE	REVISION
Prelim. Plan By		BY	APPD
Architect/Specialist			

FED. AID. PROJ. NO.	SHEET NO.	TOTAL SHEETS



BRIDGE AND STRUCTURES OFFICE

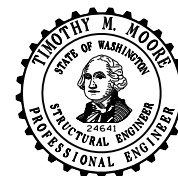

Washington State Department of Transportation

**SR 99
ALASKAN WAY VIADUCT - REPLACEMENT
S HOLGATE ST TO S KING ST - STAGE 2
BRIDGE NO. 99/540 NB & SB**

FOUNDATION PLAN 2 OF 3

BRIDGE SHEET NO.	BGO17
SHEET	863
OF	1475
SHEETS	

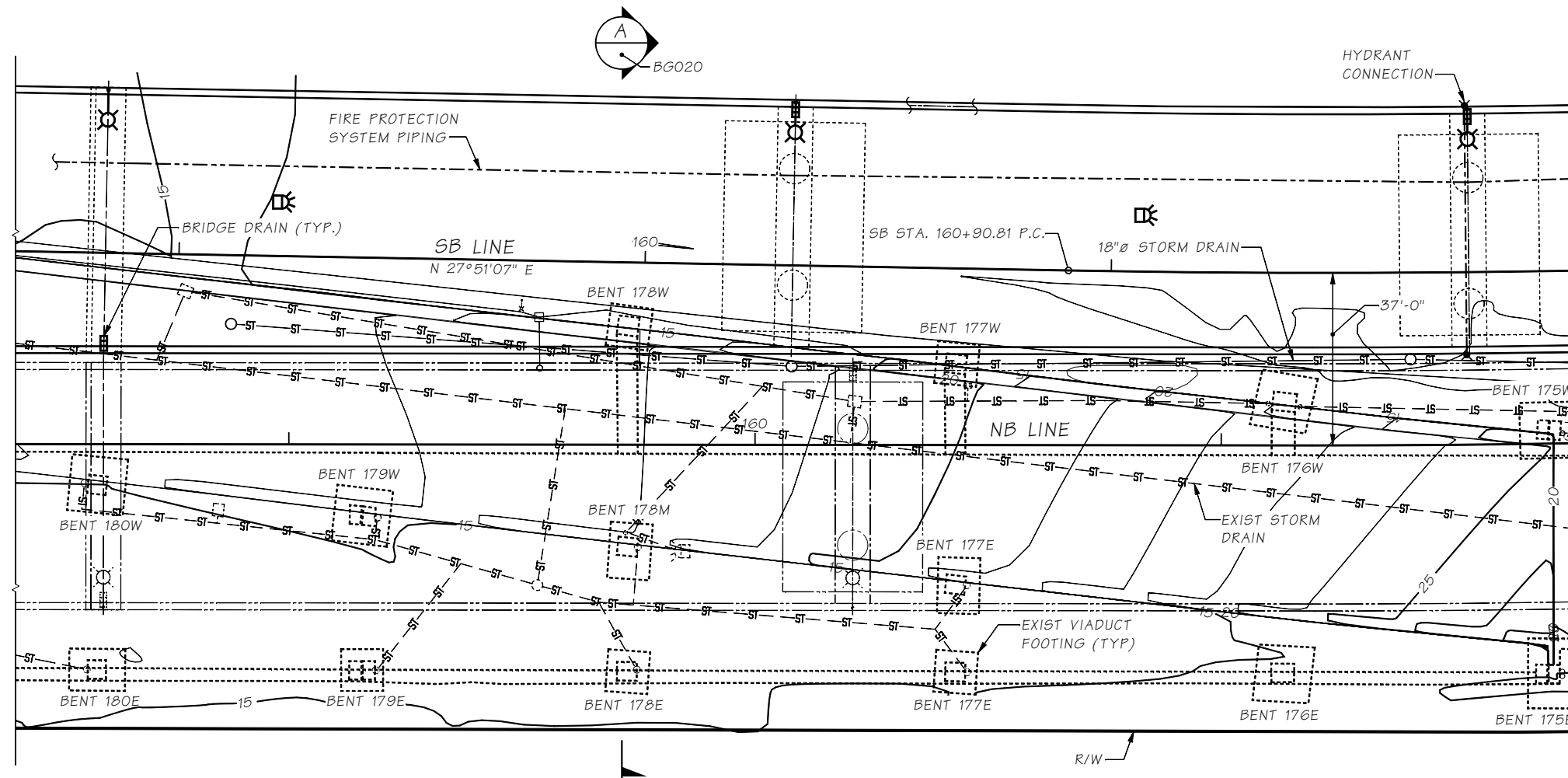
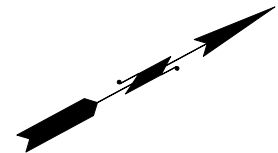

PLAN

SR 99 FILE NO. SHEET BG019

Bridge Design Engr.	Khaleghi, B	M:\Y-Team\AWV SOUTH INTERCHANGE\window files\TEMP COLUMN SUPPORT 1.WND				REGION NO.	STATE	FED. AID PROJ. NO.	SHEET NO.	TOTAL SHEETS
Supervisor	Moore, TM				10	WASH.				
Designed By	Zhang, H	04/09								
Checked By	Talukdar, M	09/09								
Detailed By	Hanson, CE	04/09								
Bridge Projects Engr.										
Prelim. Plan By		2/17/10	REVISED SHEET	CSL	TMM					
Architect/Specialist		DATE	REVISION	BY	APPD					



BRIDGE AND STRUCTURES OFFICE

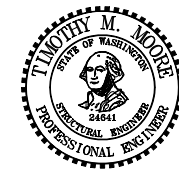

SR 99
ALASKAN WAY VIADUCT - REPLACEMENT
S HOLGATE ST TO S KING ST - PHASE 2
BRIDGE NO. 99/540 NB & SB
TEMPORARY SUPPORT AT BENT 178
DETAILS 1 OF 4

BRIDGE SHEET NO. BG019
SHEET 865 OF 1475 SHEETS

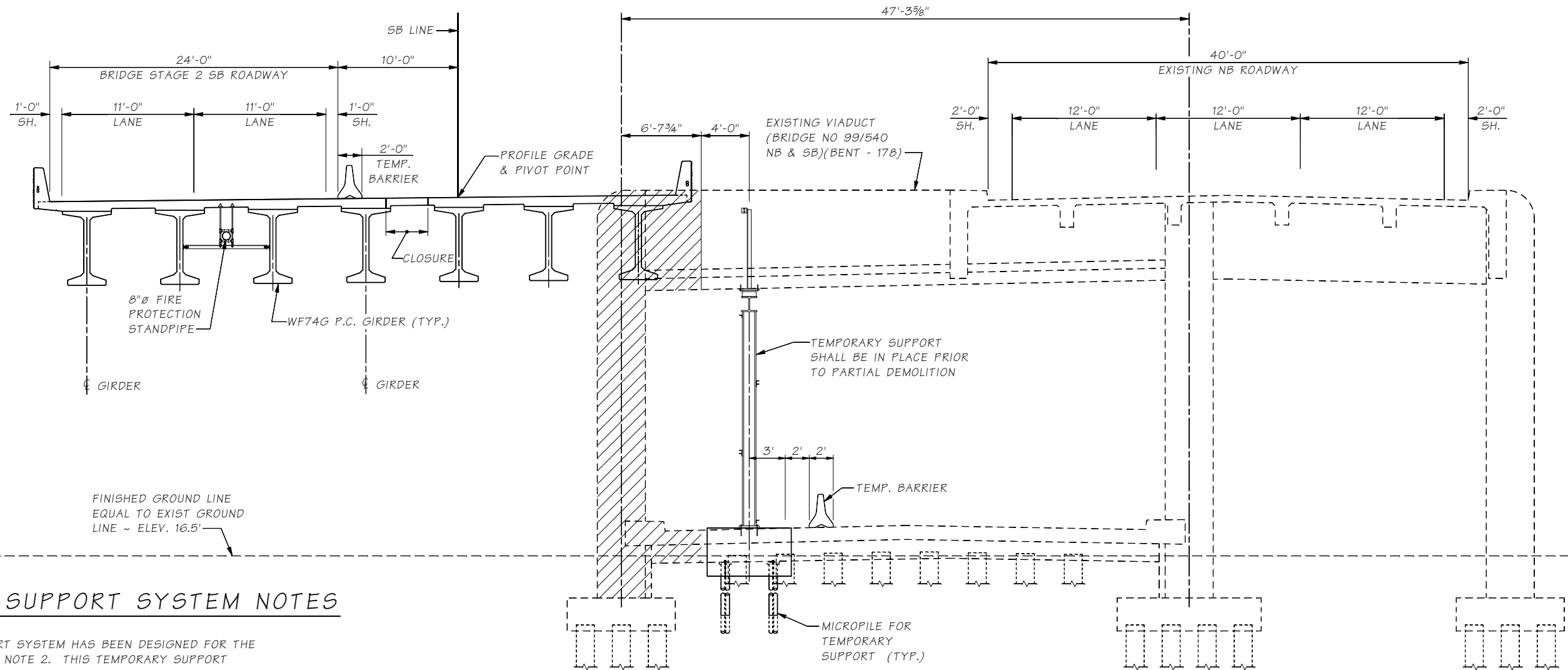

TEMPORARY SUPPORT SYSTEM NOTES

1. THE TEMPORARY SUPPORT SYSTEM HAS BEEN DESIGNED FOR THE LOADS AS DESCRIBED IN NOTE 2. THIS TEMPORARY SUPPORT SYSTEM IS A PROPOSED SYSTEM. THE CONTRACTOR MAY PROPOSE ALTERNATE MEMBER SIZES, CONNECTIONS OR OTHER MODIFICATIONS TO THE SUPPORT SYSTEM IN ACCORDANCE WITH SECTION 6-01.9 OF THE STANDARD SPECIFICATIONS.
2. THE TEMPORARY SUPPORT SYSTEM UNIT AT BENT 178W HAS BEEN DESIGNED FOR THE FOLLOWING LOADS:
 ULTIMATE VERTICAL LOAD = DL 314 KIPS
 LL 127 KIPS
 SERVICE VERTICAL LOAD = DL 251 KIPS
 LL 73 KIPS
 SERVICE WIND LOAD = 50 PSF
 LATERAL LOAD = 5% OF VERTICAL LOAD
3. MICROPILE SHALL BE DESIGNED FOR A SERVICE LOAD OF 60 TONS OR AN ULTIMATE LOAD OF 80 TONS. THE CONTRACTOR SHALL SUBMIT WORKING DRAWINGS AND DESIGN CALCULATIONS TO THE ENGINEER FOR APPROVAL AS SPECIFIED IN THE SPECIAL PROVISIONS.

LEGEND

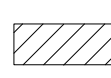
 LIMITS OF PARTIAL DEMOLITION (TO BE PERFORMED AFTER SB TRAFFIC MOVED ONTO NEW PARTIALLY COMPLETED SB BRIDGE AND APPROACH)

SECTION A

BG019

CONSTRUCTION STAGING NOTES

- STAGE 1 - MAINTAIN NORTHBOUND AND SOUTHBOUND SR 99 TRAFFIC ON EXIST VIADUCT. CONSTRUCT ENOUGH OF THE NEW SOUTHBOUND STRUCTURE TO SUPPORT 2 LANES OF TEMPORARY SOUTHBOUND TRAFFIC FOR BRIDGE CONSTRUCTION STAGE 2.
- STAGE 2 - MAINTAIN NORTHBOUND SR 99 TRAFFIC ON EXISTING VIADUCT. MOVE SOUTHBOUND SR 99 TRAFFIC ONTO NEWLY CONSTRUCTED PORTION OF THE NEW SOUTHBOUND STRUCTURE FROM STAGE 1. PROVIDE TEMPORARY SUPPORT FOR OUTRIGGER AT BENT 178. DEMOLISH EXISTING OUTRIGGER, WESTERNMOST COLUMN AND SOUTHBOUND STRUCTURE TO SPECIFIED LIMITS. REFER TO "CONSTRUCTION STAGING" BR. SHT. BG012 FOR DETAILS. FINISH CONSTRUCTING REMAINING PORTION OF NEW SOUTHBOUND STRUCTURE.
- STAGE 3 - MOVE NORTHBOUND SR 99 TRAFFIC ONTO NEWLY CONSTRUCTED SOUTHBOUND STRUCTURE. TWO TEMPORARY SOUTHBOUND LANES AND TWO TEMPORARY NORTHBOUND LANES WILL BE SUPPORTED ON THE NEW SOUTHBOUND STRUCTURE. DEMOLISH THE EXISTING VIADUCT. CONSTRUCT THE NEW NORTHBOUND STRUCTURE. REFER TO "CONSTRUCTION STAGING" BR. SHT. BG012 FOR DETAILS.

GENERAL NOTES

1. STRUCTURAL STEEL FOR STRUCTURAL SHAPES SHALL CONFORM TO ASTM A992. ALL OTHER STEEL SHALL CONFORM TO ASTM A36.
2. ALL HIGH STRENGTH REBARS SHALL BE ACCORDING TO SECTION 9-07.11 OF THE STANDARD SPECIFICATIONS FOR ROAD, BRIDGE AND MUNICIPAL CONSTRUCTION 2008.
3. THE CONCRETE IN THE MICROPILE CAP SHALL BE CLASS 4000.
4. ALL WELDING SHALL BE DONE TO MINIMIZE DISTORTION. THE WELDING SEQUENCES AND PROCEDURES TO BE USED SHALL BE SUBMITTED TO THE ENGINEER FOR APPROVAL PRIOR TO THE START OF WELDING.
5. THE WELDING OF STEEL WEDGE TO STEEL WEDGE, STEEL WEDGE TO HORIZONTAL BEAM, STEEL WEDGE TO THE TOP STEEL PLATE SHALL BE FIELD WELDING.
6. ALL STRUCTURAL STEEL SHALL BE UNPAINTED UNLESS OTHERWISE NOTED.
7. ALL DIMENSIONS ARE HORIZONTAL AND VERTICAL UNLESS OTHERWISE SHOWN.

SR 99 FILE NO. SHEET BG020

Bridge Design Engr.	Khaleghi, B	M:\Y-Team\AWV SOUTH INTERCHANGE\window files\TEMP COLUMN SUPPORT 2.WND				REGION NO.	STATE	FED. AID PROJ. NO.	SHEET NO.	TOTAL SHEETS
Supervisor	Moore, TM					10	WASH.			
Designed By	Zhang, H	04/09								
Checked By	Talukdar, M	09/09								
Detailed By	Lemcke, DR	09/09								
Bridge Projects Engr.										
Prelim. Plan By										
Architect/Specialist		DATE	REVISION	BY	APPD					



BRIDGE AND STRUCTURES OFFICE

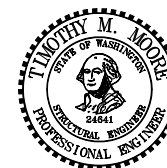

SR 99
ALASKAN WAY VIADUCT - REPLACEMENT
S HOLGATE ST TO S KING ST - PHASE 2
BRIDGE NO. 99/540 NB & SB
TERMPORARY SUPPORT AT BENT 178
DETAILS 2 OF 4

BRIDGE SHEET NO. BG020
SHEET 866 OF 1475 SHEETS

SR 99 FILE NO. SHEET BG021

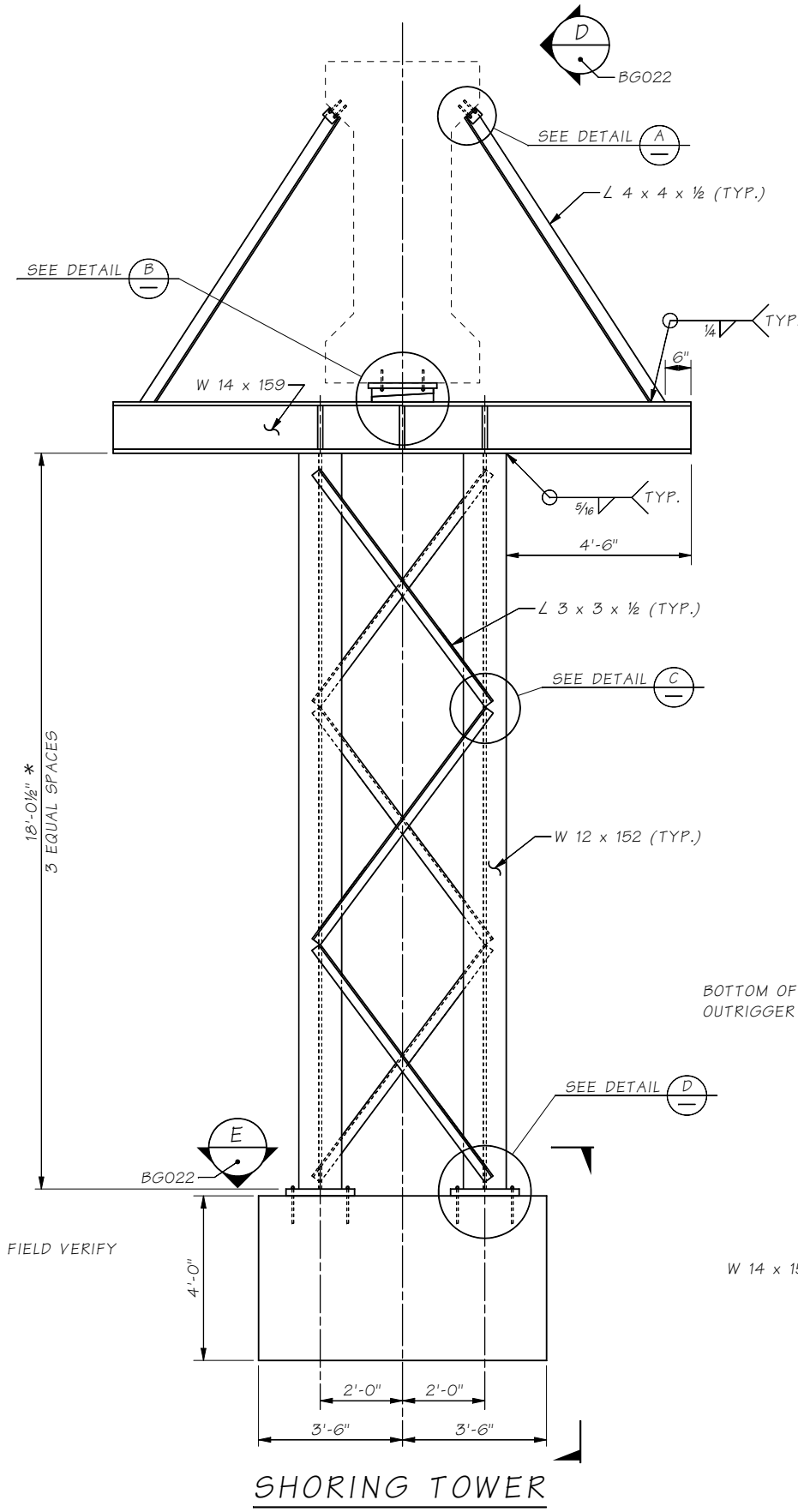

SHORING TOWER

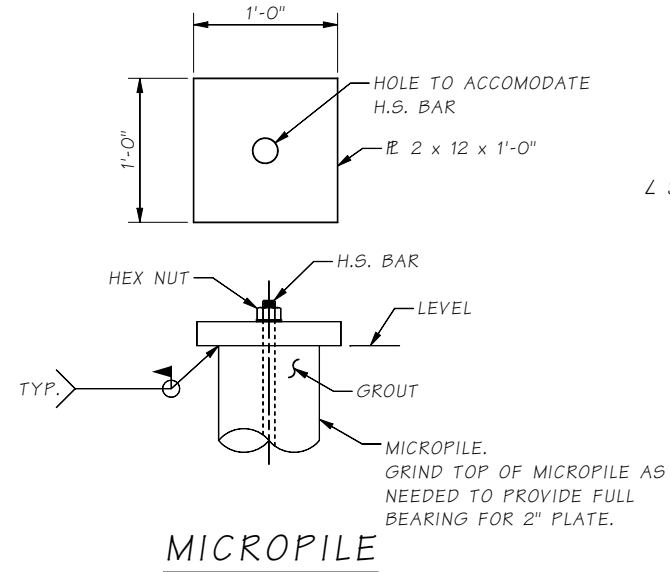

MICROPILE

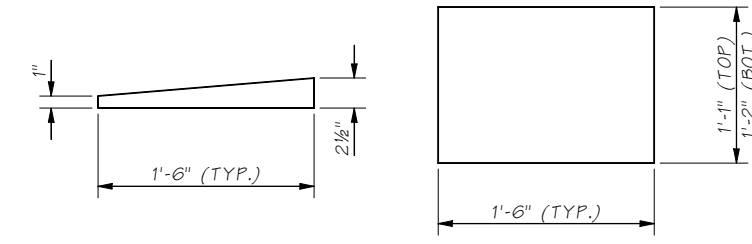

STEEL WEDGE DETAIL

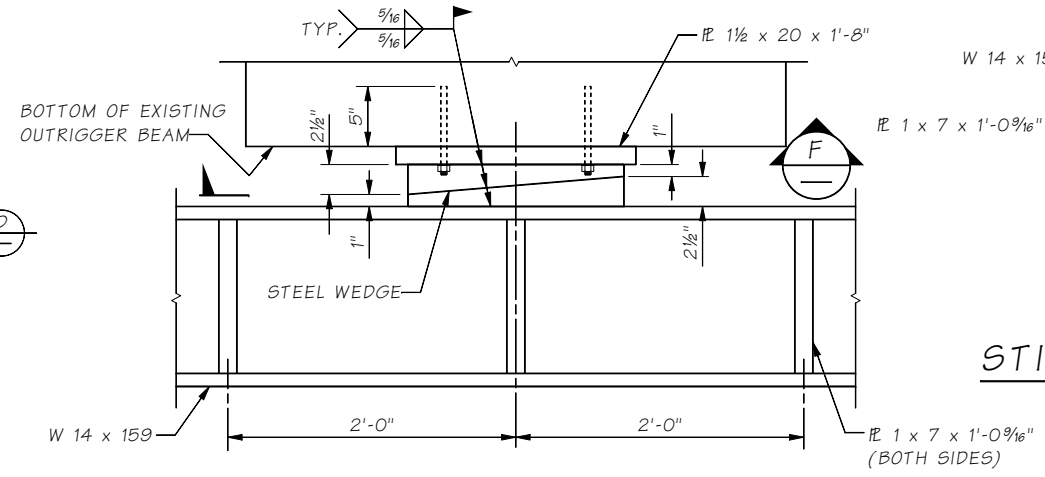

DETAIL B

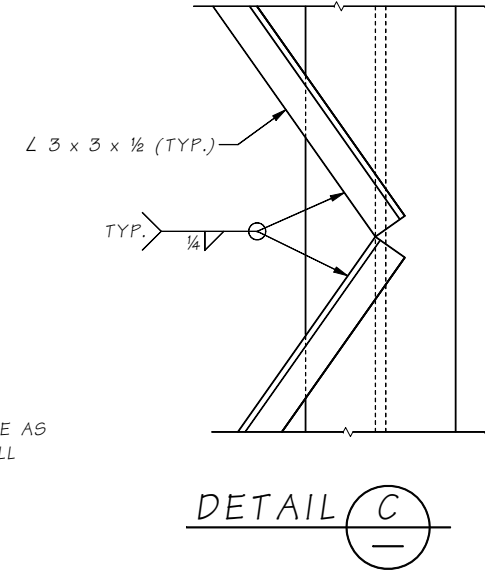

DETAIL C

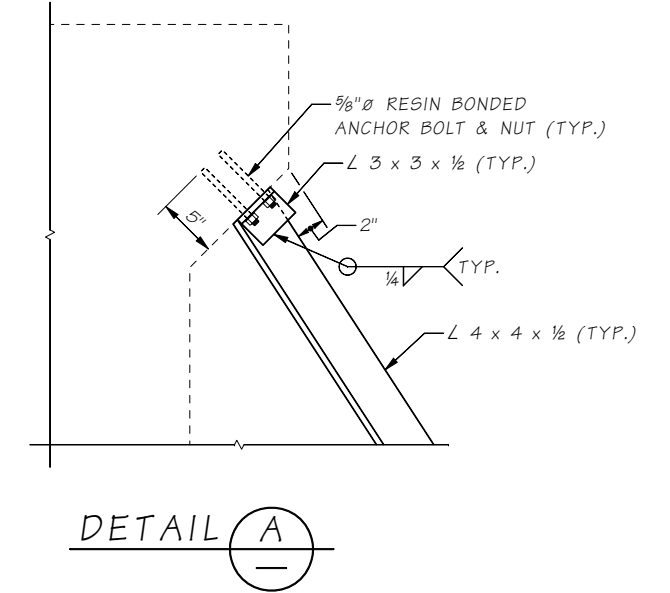

DETAIL A

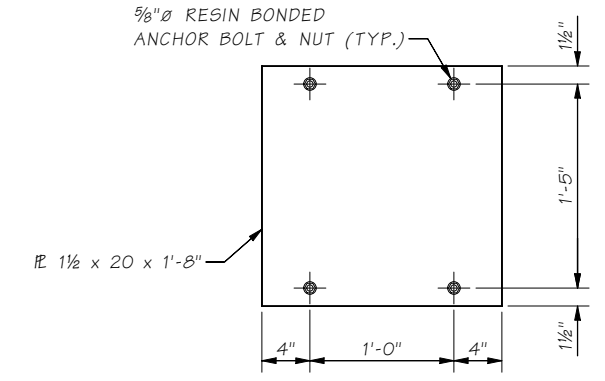

SECTION F

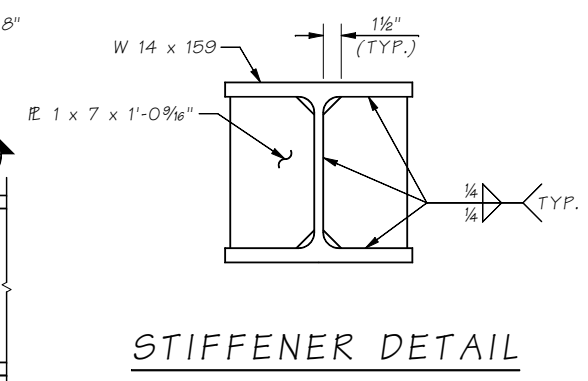

STIFFENER DETAIL

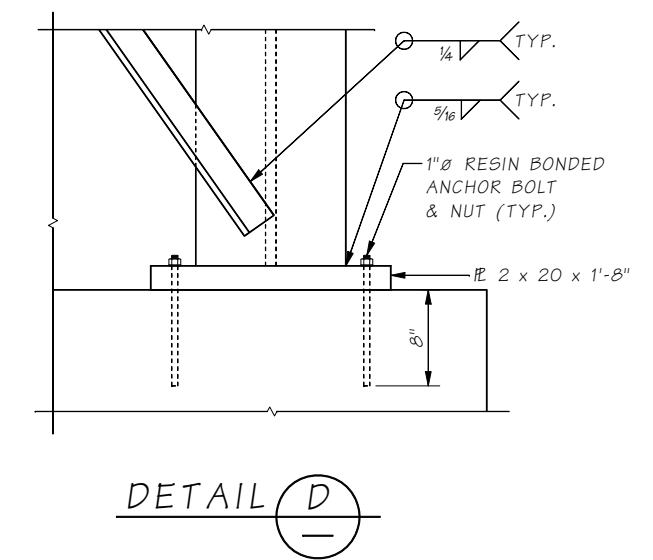

DETAIL D

Bridge Design Engr.	Khaleghi, B	M:\Y-Team\AWV SOUTH INTERCHANGE\window files\TEMP COLUMN SUPPORT 3.WND			
Supervisor	Moore, TM	REGION NO.	STATE	FED. AID PROJ. NO.	SHEET NO.
Designed By	Zhang, H	10	WASH.		TOTAL SHEETS
Checked By	Talukdar, M	JOB NUMBER 09A803			
Detailed By	Lemcke, DR				
Bridge Projects Engr.					
Prelim. Plan By					
Architect/Specialist		DATE	REVISION	BY	APPD



BRIDGE AND STRUCTURES OFFICE

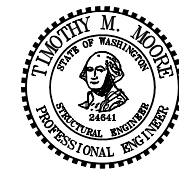

SR 99
ALASKAN WAY VIADUCT - REPLACEMENT
S HOLGATE ST TO S KING ST - PHASE 2
BRIDGE NO. 99/540 NB & SB
TEMPORARY SUPPORT AT BENT 178
DETAILS 3 OF 4

BRIDGE SHEET NO. BG021
SHEET 867 OF 1475 SHEETS

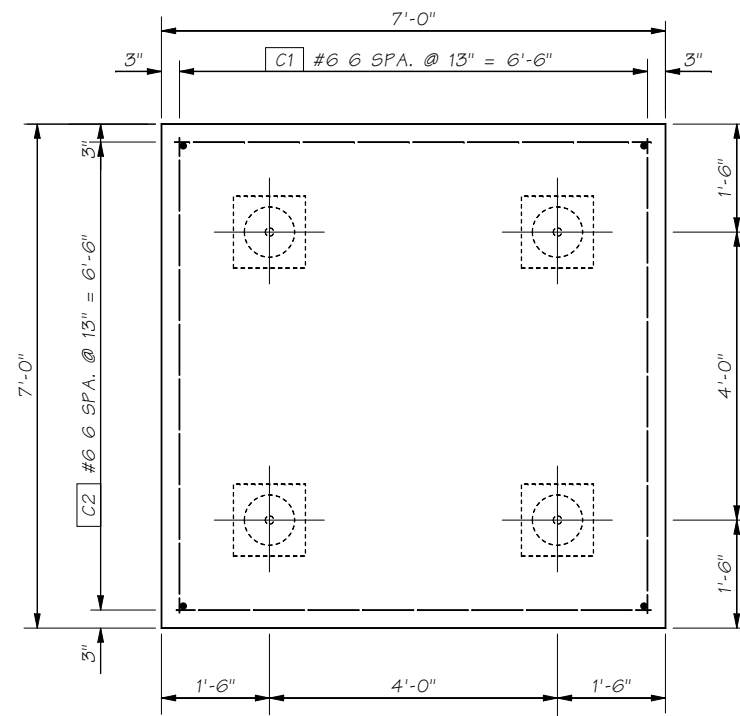

MICROPILE CAP PLAN
TOP MAT

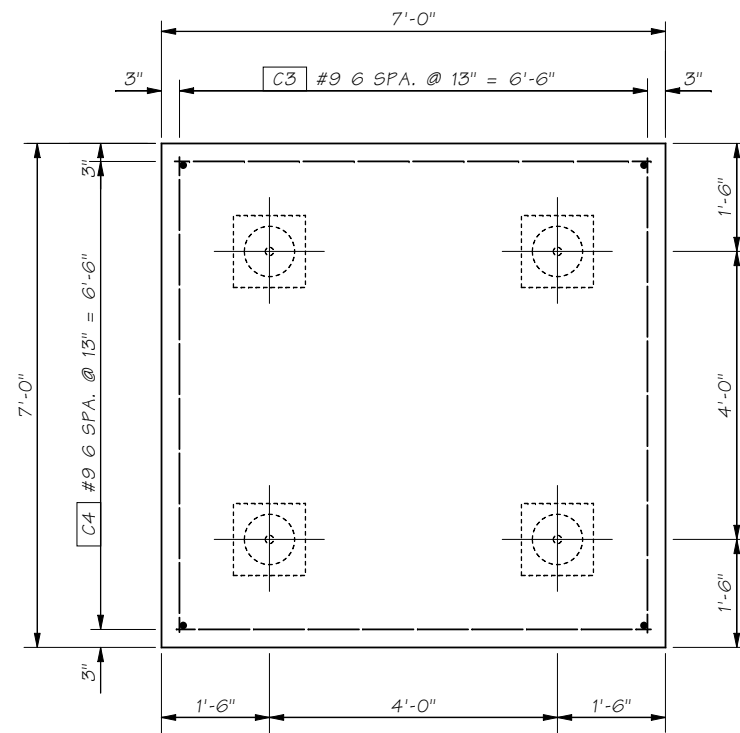

MICROPILE CAP PLAN
BOTTOM MAT

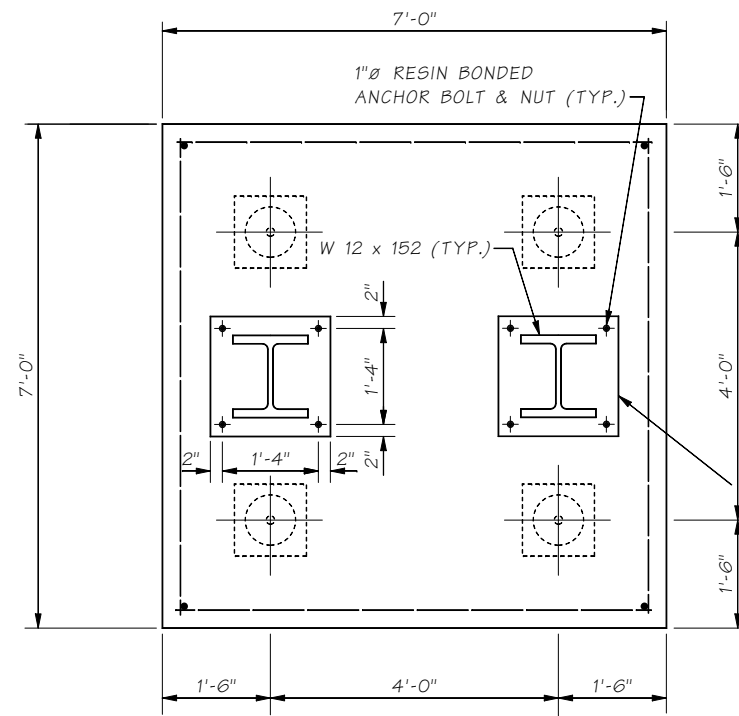

SECTION E
BG021

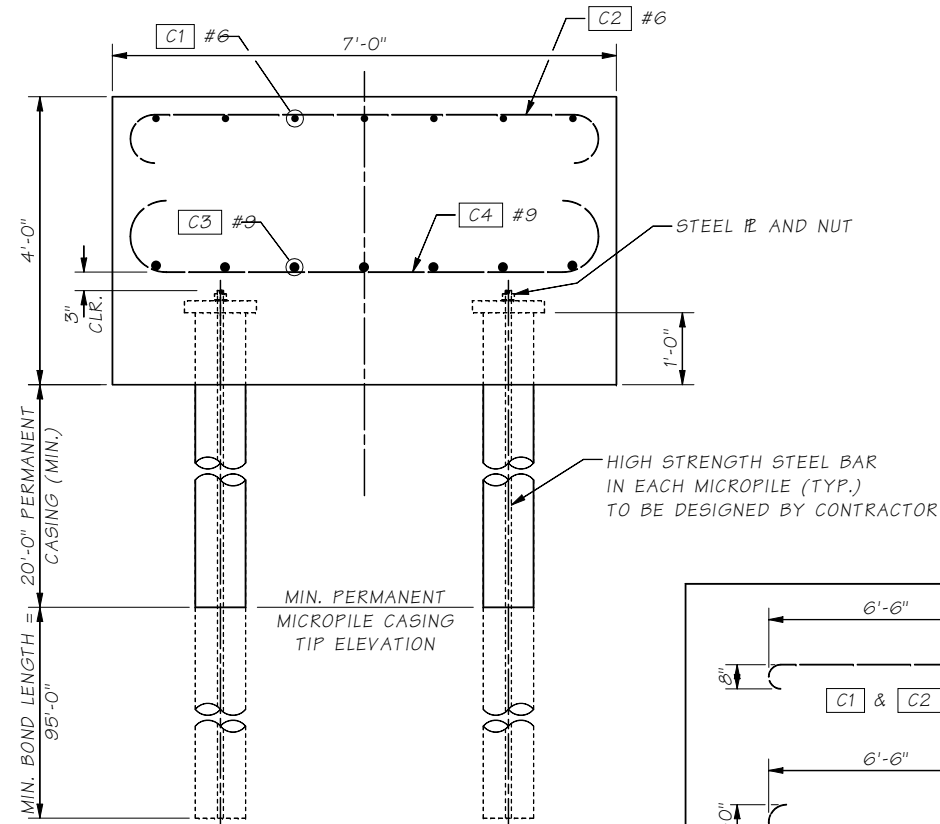

MICROPILE & CAP

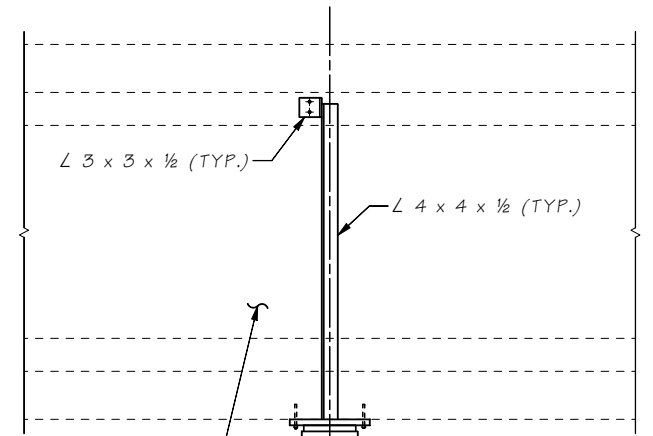
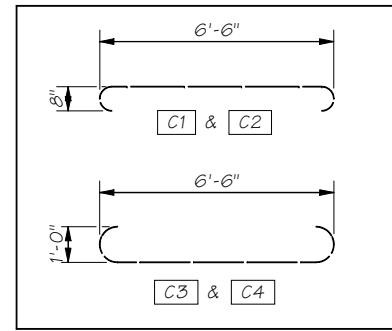

SECTION D
BG021, BG023

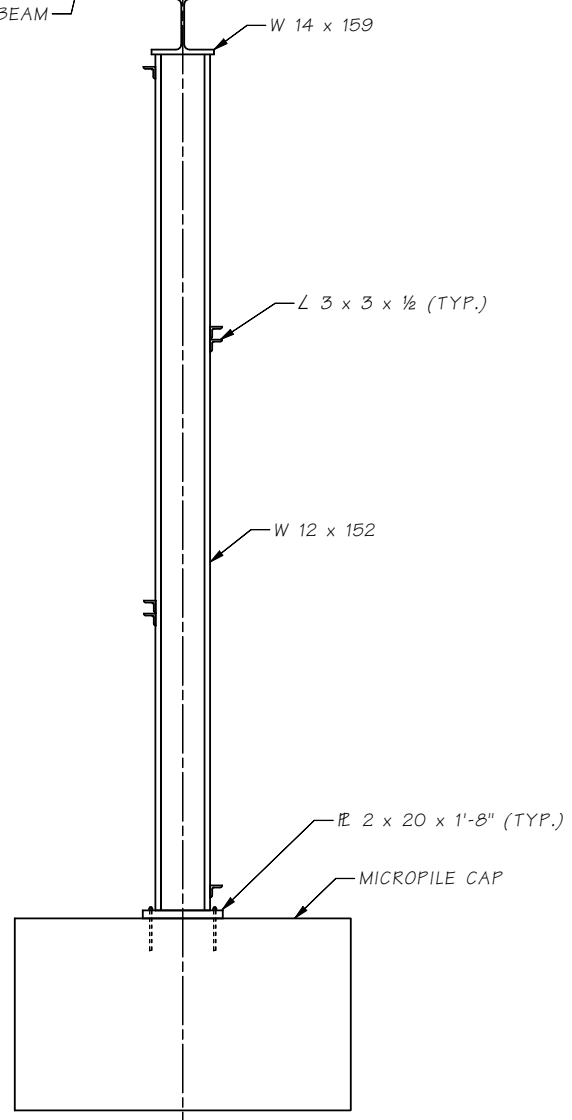

SR 99 FILE NO. SHEET BG022

Bridge Design Engr.	Khaleghi, B	M:\Y-Team\AWV SOUTH INTERCHANGE\window files\TEMP COLUMN SUPPORT 4.WND			
Supervisor	Moore, TM	REGION NO.	STATE	FED. AID PROJ. NO.	SHEET NO.
Designed By	Zhang, H 04/09	10	WASH.		TOTAL SHEETS
Checked By	Talukdar, M 09/09	JOB NUMBER 09A803			
Detailed By	Lemcke, DR 06/09				
Bridge Projects Engr.					
Prelim. Plan By					
Architect/Specialist		DATE	REVISION	BY	APPD



BRIDGE AND STRUCTURES OFFICE

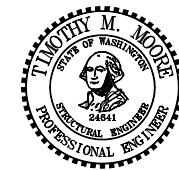

SR 99
ALASKAN WAY VIADUCT - REPLACEMENT
S HOLGATE ST TO S KING ST - PHASE 2
BRIDGE NO. 99/540 NB & SB

TEMPORARY SUPPORT AT BENT 178
DETAILS 4 OF 4

BRIDGE SHEET NO. BG022
SHEET 868 OF 1475 SHEETS

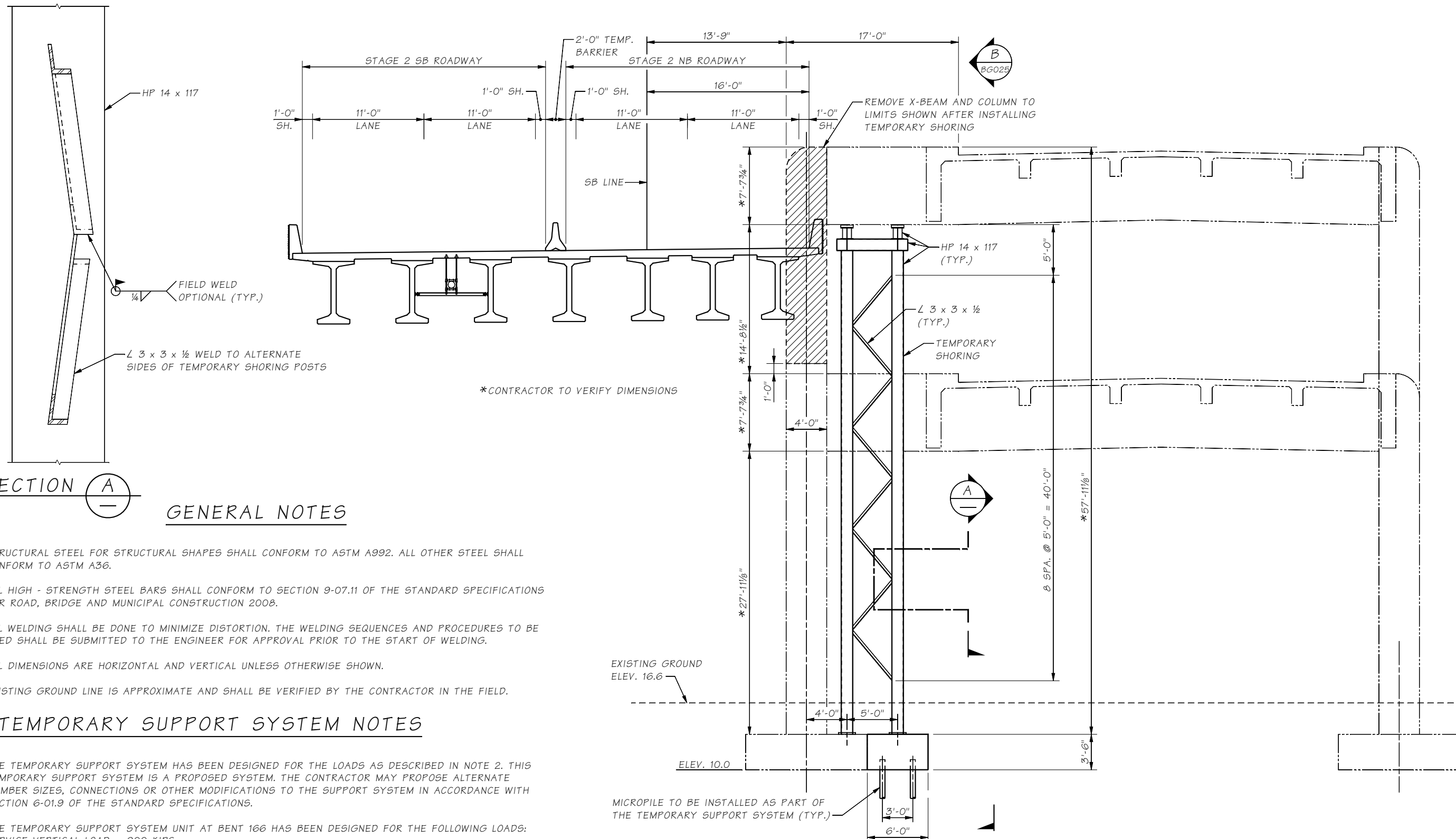

SECTION A

GENERAL NOTES

1. STRUCTURAL STEEL FOR STRUCTURAL SHAPES SHALL CONFORM TO ASTM A992. ALL OTHER STEEL SHALL CONFORM TO ASTM A36.
2. ALL HIGH - STRENGTH STEEL BARS SHALL CONFORM TO SECTION 9-07.11 OF THE STANDARD SPECIFICATIONS FOR ROAD, BRIDGE AND MUNICIPAL CONSTRUCTION 2008.
3. ALL WELDING SHALL BE DONE TO MINIMIZE DISTORTION. THE WELDING SEQUENCES AND PROCEDURES TO BE USED SHALL BE SUBMITTED TO THE ENGINEER FOR APPROVAL PRIOR TO THE START OF WELDING.
4. ALL DIMENSIONS ARE HORIZONTAL AND VERTICAL UNLESS OTHERWISE SHOWN.
5. EXISTING GROUND LINE IS APPROXIMATE AND SHALL BE VERIFIED BY THE CONTRACTOR IN THE FIELD.

TEMPORARY SUPPORT SYSTEM NOTES

1. THE TEMPORARY SUPPORT SYSTEM HAS BEEN DESIGNED FOR THE LOADS AS DESCRIBED IN NOTE 2. THIS TEMPORARY SUPPORT SYSTEM IS A PROPOSED SYSTEM. THE CONTRACTOR MAY PROPOSE ALTERNATE MEMBER SIZES, CONNECTIONS OR OTHER MODIFICATIONS TO THE SUPPORT SYSTEM IN ACCORDANCE WITH SECTION 6-01.9 OF THE STANDARD SPECIFICATIONS.
2. THE TEMPORARY SUPPORT SYSTEM UNIT AT BENT 166 HAS BEEN DESIGNED FOR THE FOLLOWING LOADS:
 SERVICE VERTICAL LOAD = 900 KIPS
 SERVICE WIND LOAD = 50 PSF
 LATERAL LOAD = 5% OF SERVICE VERTICAL LOAD
3. MICROPILES SHALL BE DESIGNED FOR A SERVICE DESIGN LOAD OF 75 TONS COMPRESSION OR A FACTORED DESIGN LOAD OF 100 TONS COMPRESSION. THE CONTRACTOR SHALL SUBMIT WORKING DRAWINGS AND DESIGN CALCULATIONS TO THE ENGINEER FOR APPROVAL AS SPECIFIED IN THE SPECIAL PROVISIONS.

EXISTING VIADUCT BENT 166

SR 99 FILE NO. SHEET BG023

Bridge Design Engr.	Khaleghi, B	M:\Y-Team\AWV SOUTH INTERCHANGE\window files\Bent 166 Rehab Dtls 1.WND			
Supervisor	Moore, TM	REGION NO.	STATE	FED. AID PROJ. NO.	SHEET NO.
Designed By	Talukdar, M	10	WASH.		TOTAL SHEETS
Checked By	Rodda, NT	JOB NUMBER 09A803			
Detailed By	Evans, A				
Bridge Projects Engr.					
Prelim. Plan By					
Architect/Specialist		DATE	REVISION	BY	APPD



BRIDGE AND STRUCTURES OFFICE

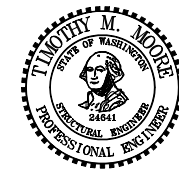

SR 99
ALASKAN WAY VIADUCT - REPLACEMENT
S HOLGATE ST TO S KING ST - PHASE 2
 BRIDGE NO. 99/540 NB & SB
TEMPORARY SUPPORT AT BENT 166
 DETAILS 1 OF 3

BRIDGE SHEET NO. **BG023**
 SHEET 869 OF 1475 SHEETS

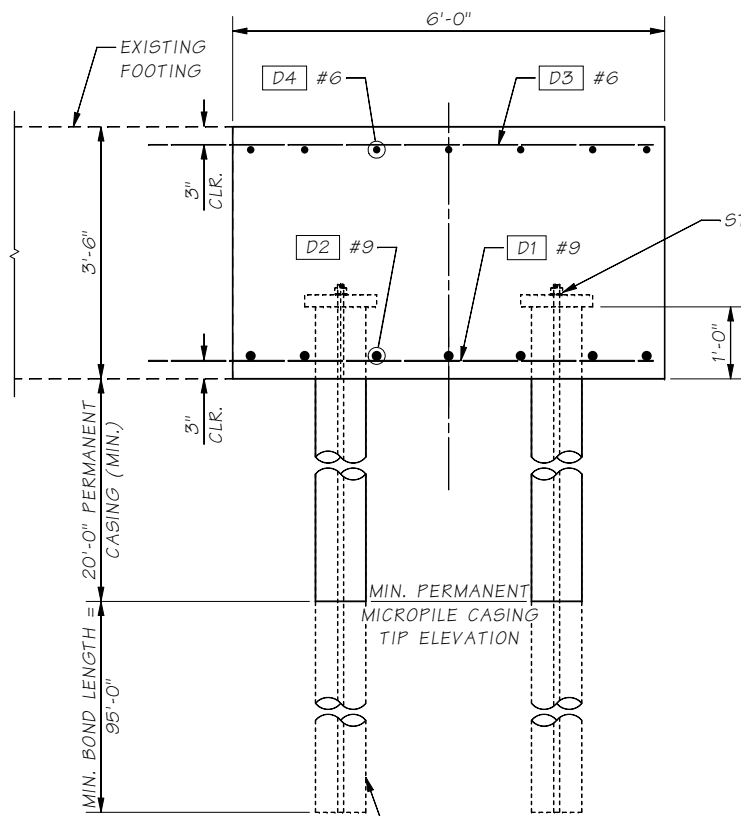

MICROPILE & CAP

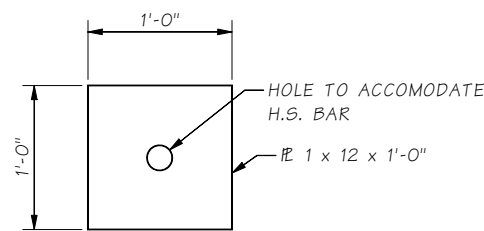

MICROPILE

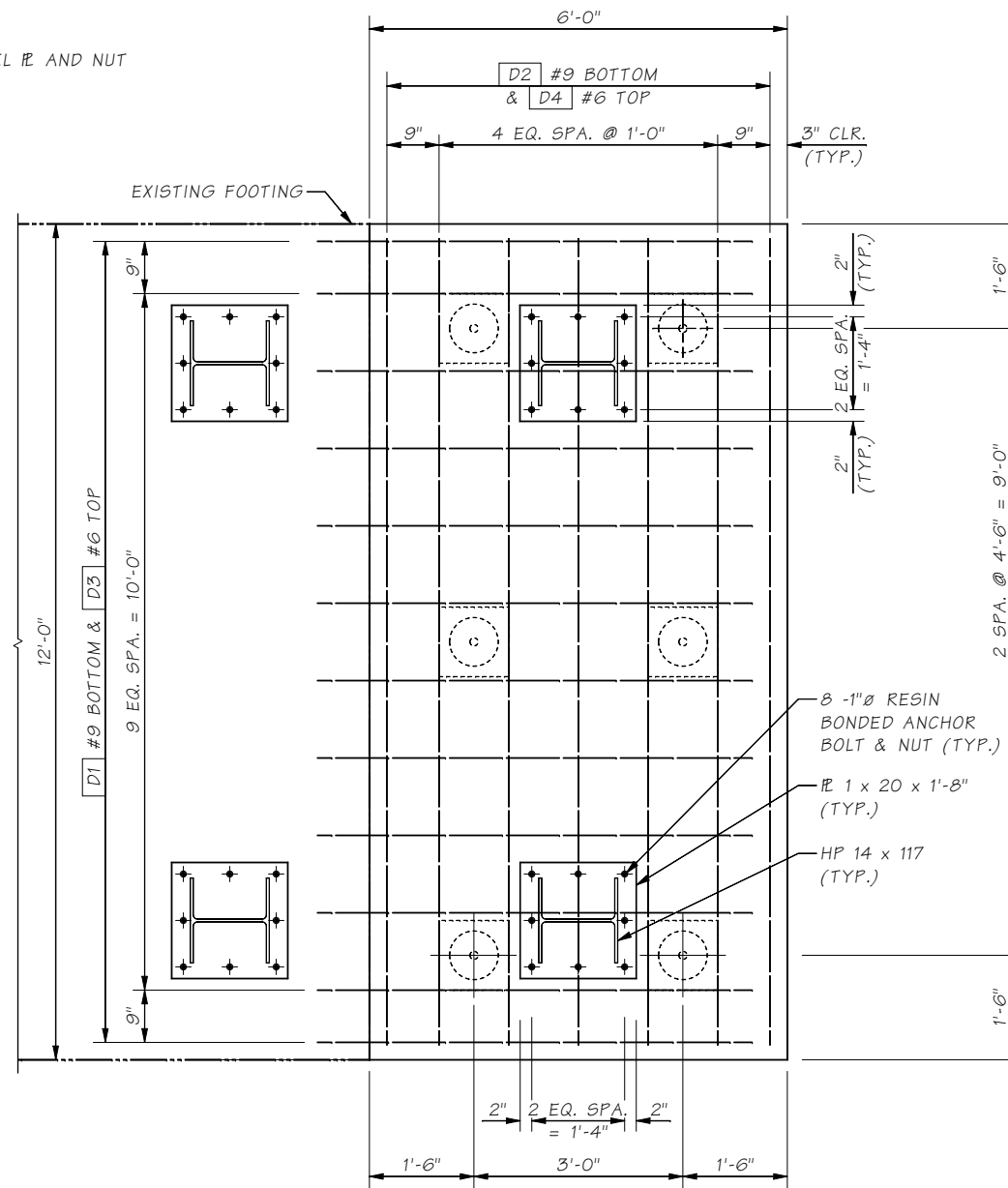
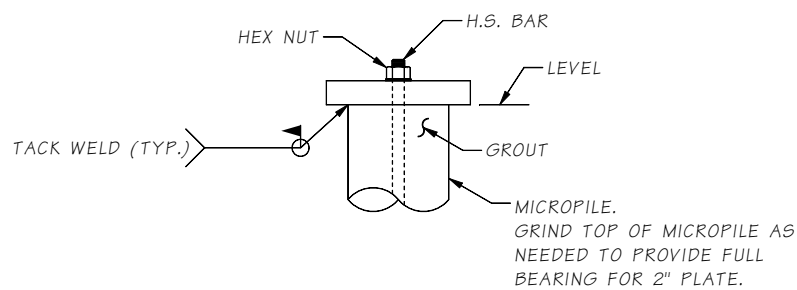

FOOTING PLAN DETAIL

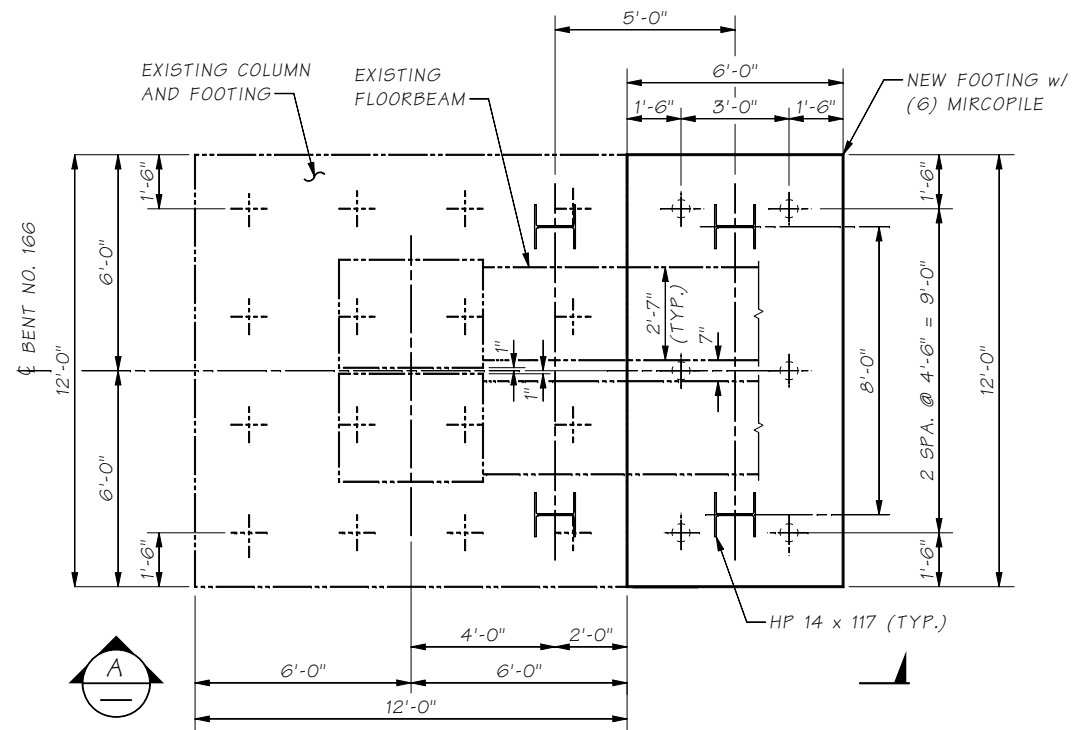
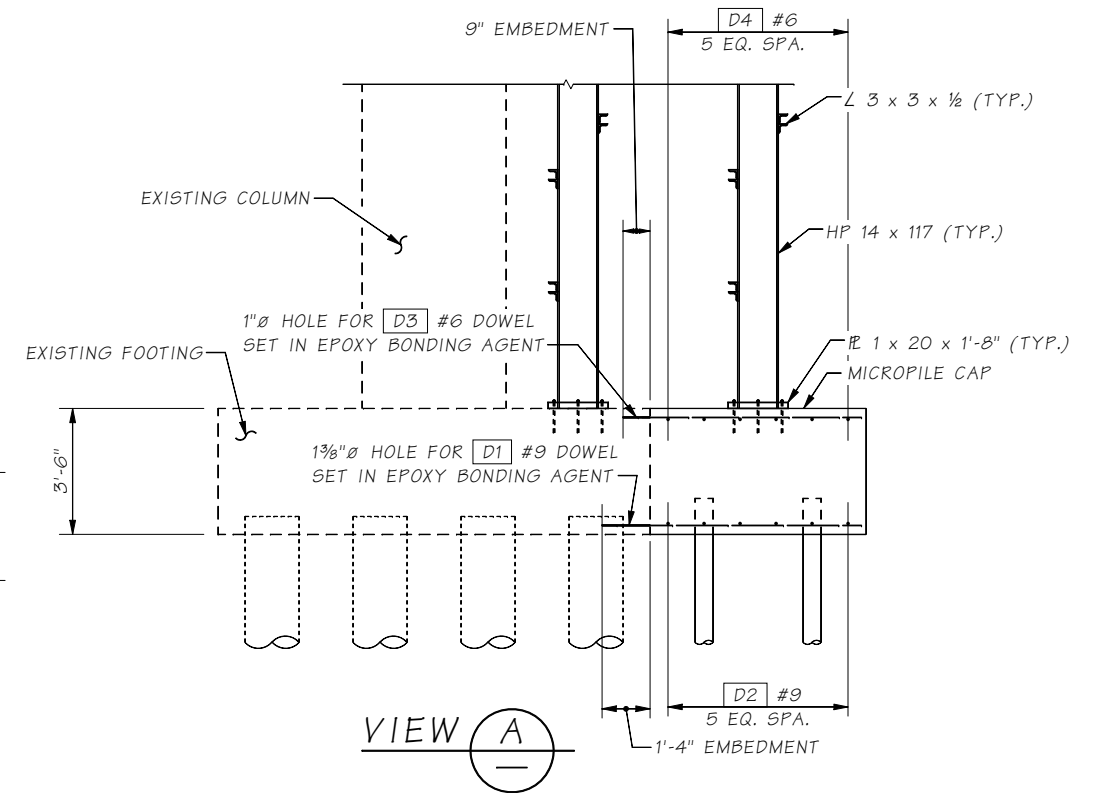

FOOTING PLAN

SR FILE NO. SHEET

Bridge Design Engr.	Khaleghi, B	M:\Y-Team\AWV SOUTH INTERCHANGE\window files\Bent 166 Rehab Dtls 2.WND			
Supervisor	Moore, TM	REGION NO.	STATE	FED. AID PROJ. NO.	SHEET NO.
Designed By	Talukdar, M	10	WASH.		TOTAL SHEETS
Checked By	Rodda, NT	JOB NUMBER 09A803			
Detailed By	Evans, A				
Bridge Projects Engr.					
Prelim. Plan By					
Architect/Specialist		DATE	REVISION	BY	APPD



BRIDGE AND STRUCTURES OFFICE



SR 99
ALASKAN WAY VIADUCT - REPLACEMENT
S HOLGATE ST TO S KING ST - PHASE 2
BRIDGE NO. 99/540 NB & SB

TEMPORARY SUPPORT AT BENT 166
DETAILS 2 OF 3

BRIDGE SHEET NO. BGO24
SHEET 870 OF 1475 SHEETS

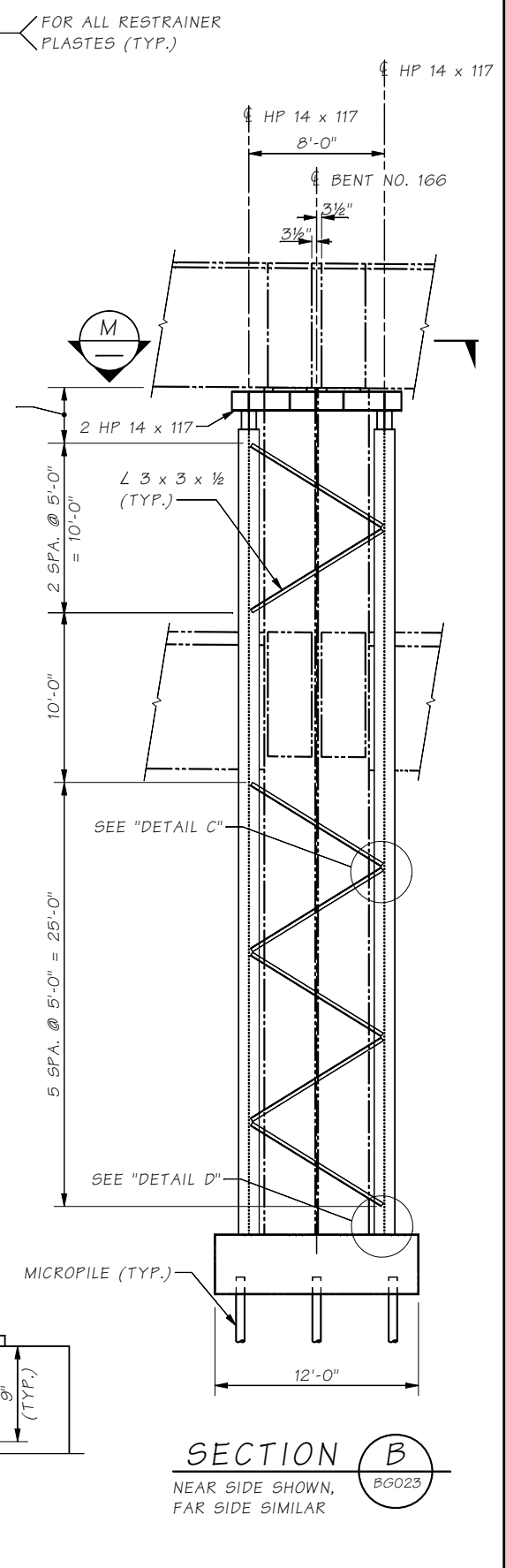
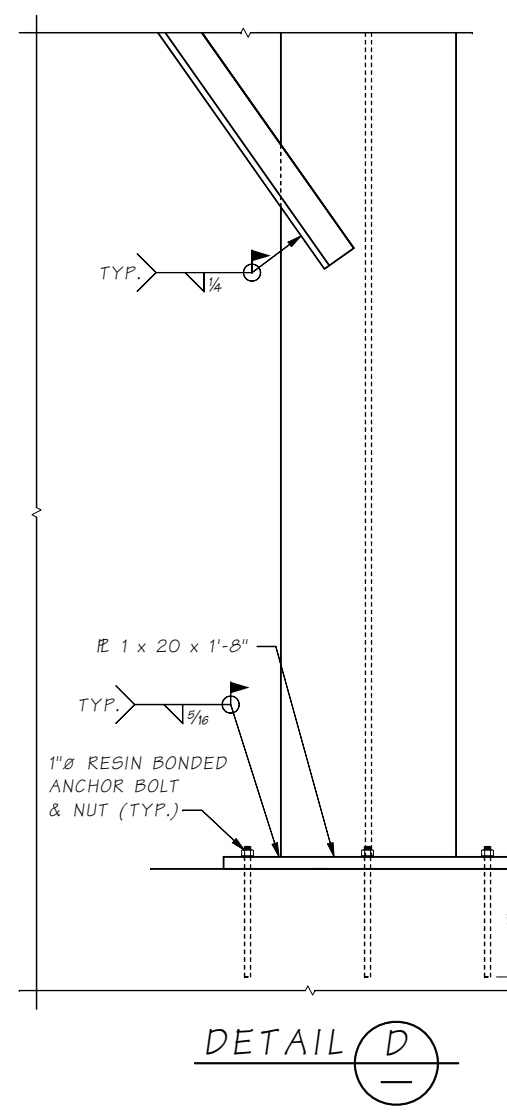
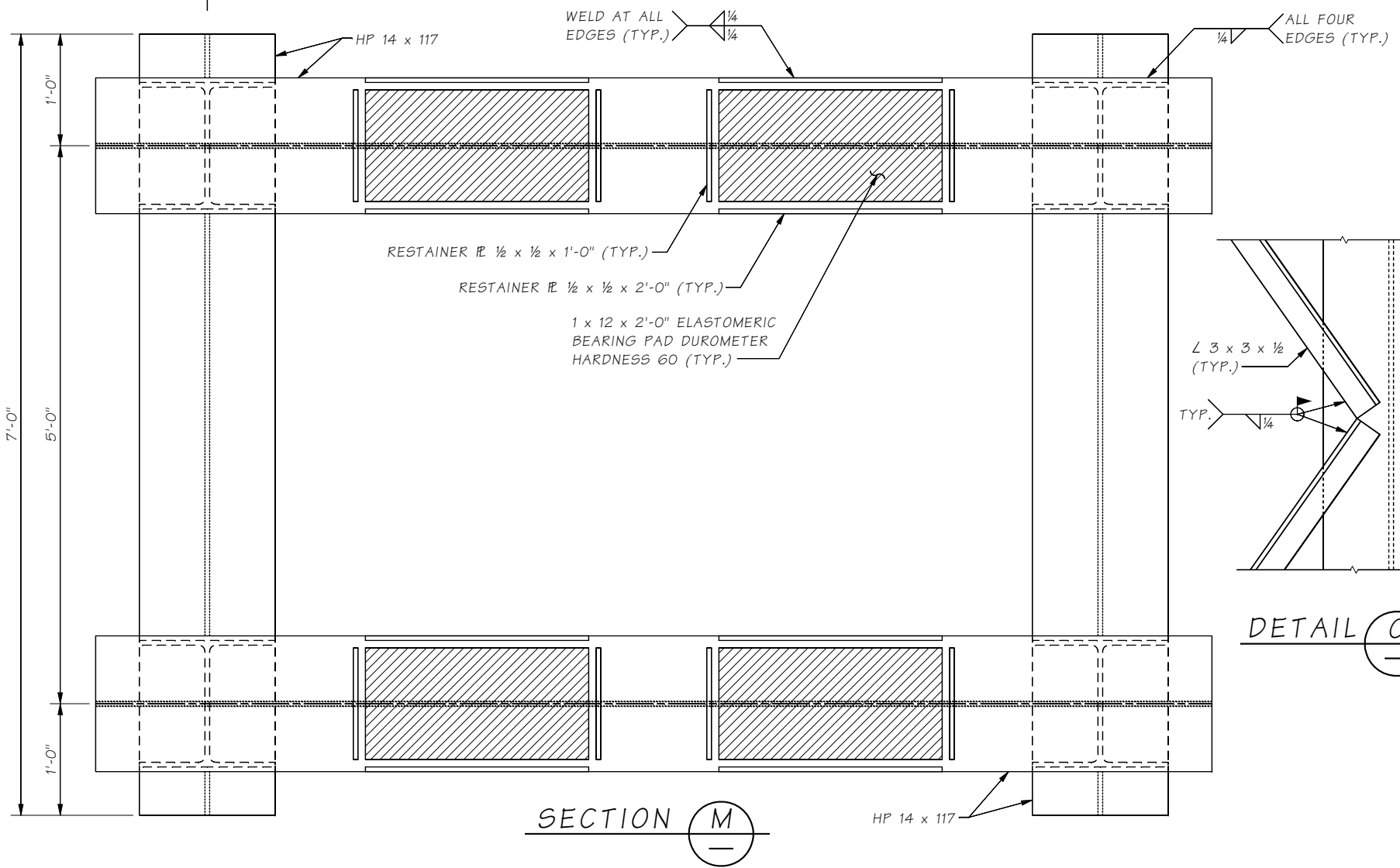
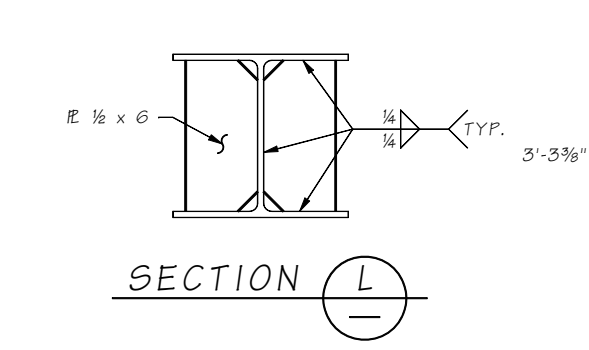
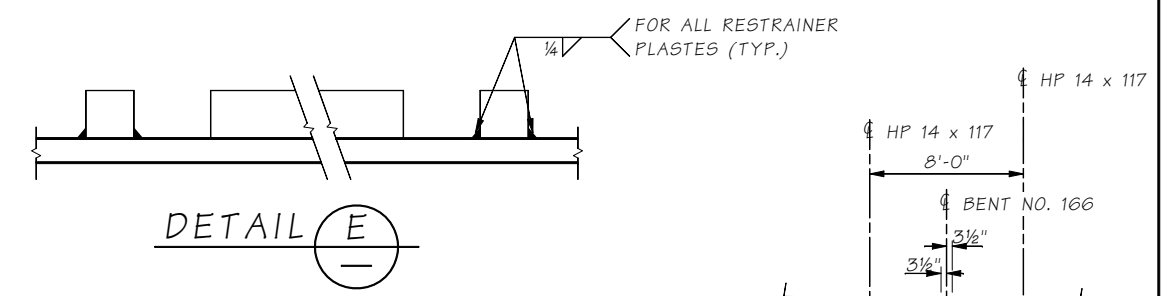
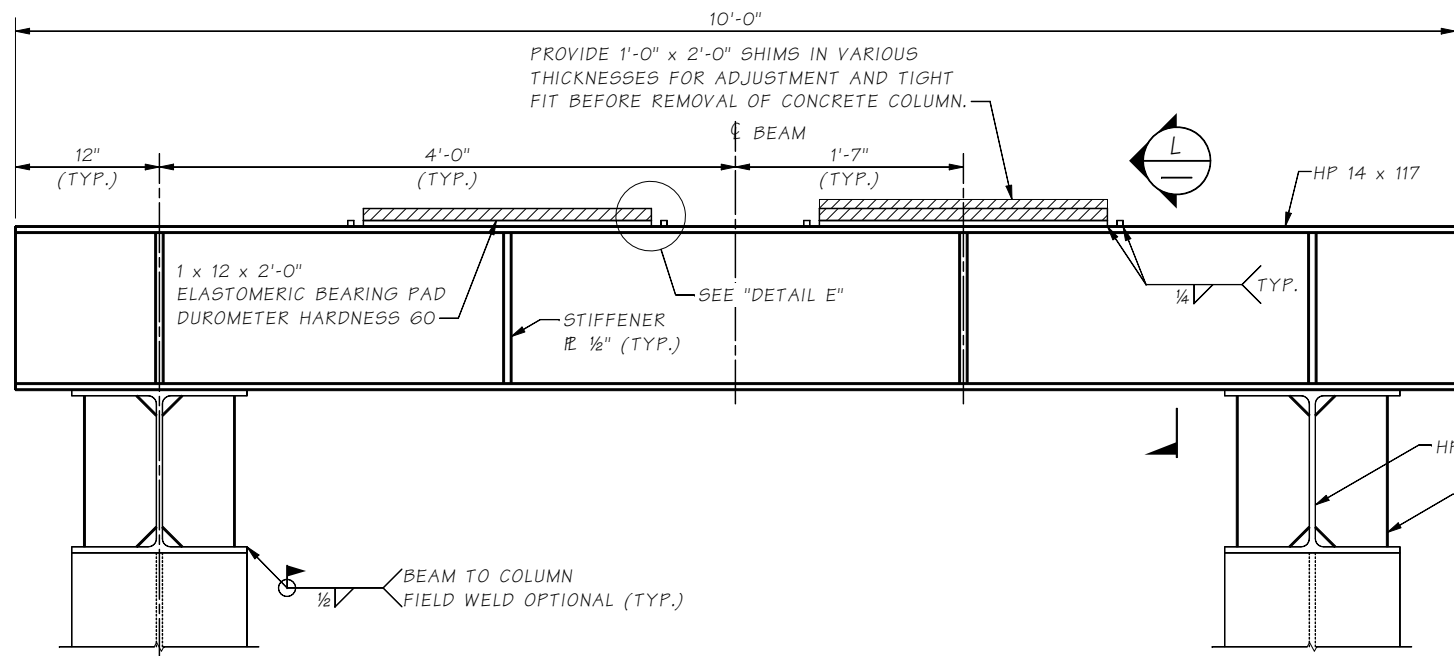

SR 99 FILE NO. SHEET BG025

Bridge Design Engr.	Khaleghi, B	M:\Y-Team\AWV SOUTH INTERCHANGE\window files\Bent 166 Rehab Dtls 3.WND				REGION NO.	STATE	FED. AID PROJ. NO.	SHEET NO.	TOTAL SHEETS
Supervisor	Moore, TM					10	WASH.			
Designed By	Talukdar, M	07/09								
Checked By	Rodda, NT	09/09								
Detailed By	Evans, A	08/09								
Bridge Projects Engr.						JOB NUMBER				
Prelim. Plan By						09A803				
Architect/Specialist		DATE	REVISION	BY	APPD					



BRIDGE AND STRUCTURES OFFICE

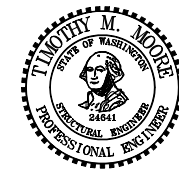

SR 99
ALASKAN WAY VIADUCT - REPLACEMENT
S HOLGATE ST TO S KING ST - PHASE 2
BRIDGE NO. 99/540 NB & SB

TEMPORARY SUPPORT AT BENT 166
DETAILS 3 OF 3

BRIDGE SHEET NO. BG025

SHEET 871 OF 1475 SHEETS

Fri Feb 12 13:01:12 2010

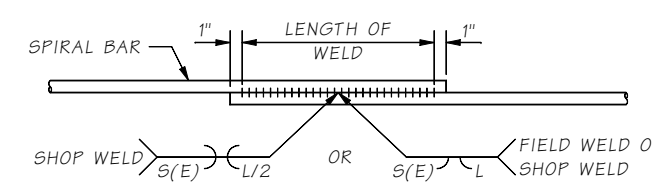
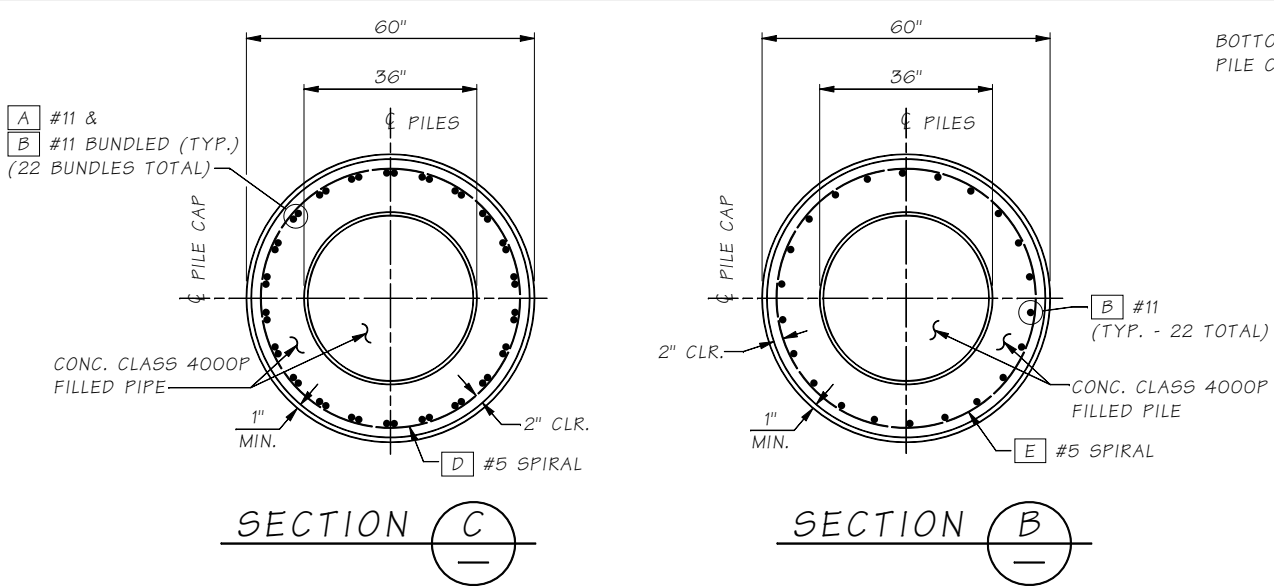
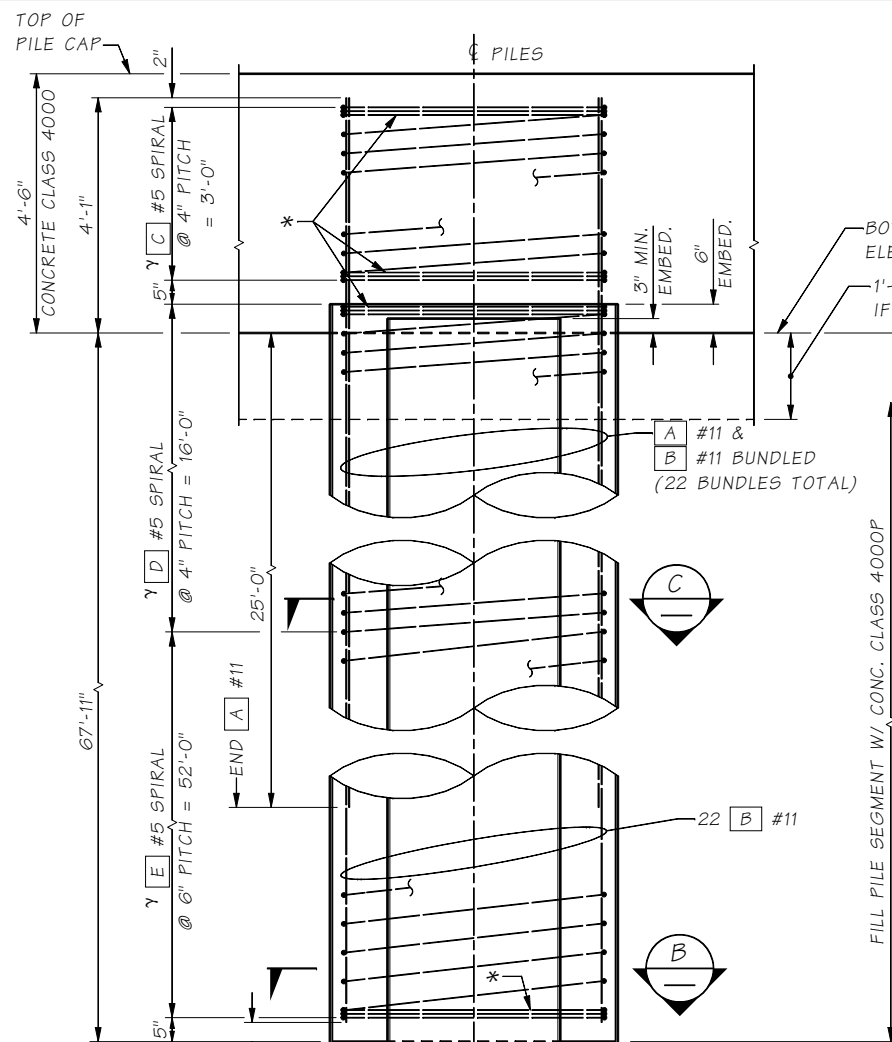

WELDED LAP SPlice DETAIL

WELDING SHALL MEET THE REQUIREMENTS OF STD. SPEC. 6-02.3(24)E FOR WELD DIMENSIONS, SEE TABLE BELOW.

DEFORMED BAR	WELD DIMENSIONS		
	S	E	LENGTH (L)
#5	3/16	3/16	6"

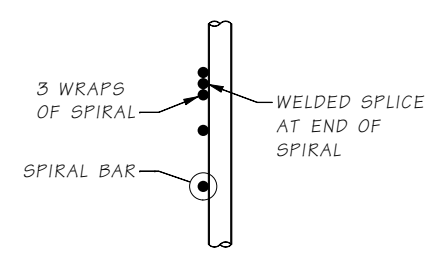

SPIRAL TERMINATION DETAIL

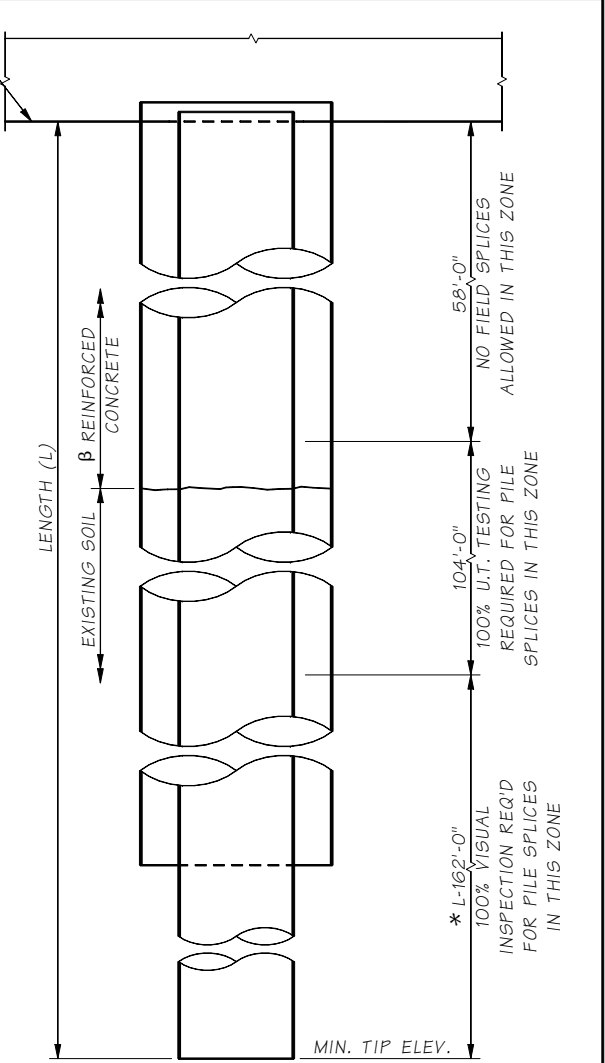

100% U.T. INSPECTION LIMITS

* ALL FIELD SPLICES FOR TEST PILE REQUIRE 100% U.T. TESTING
 B SEE TYPICAL PILE ELEVATION ON THIS SHEET FOR REINFORCING DETAILS

* SEE SPIRAL TERMINATION DETAIL ON THIS SHEET.
 γ WELDED SPlice ONLY (SEE WELDED LAP SPlice DETAIL ON THIS SHEET)

NOTE: DURING DRIVING OF 36"Ø PILE INSIDE THE 60"Ø PILE, THE CONTRACTOR SHALL PROVIDE A MANDREL OR SOME MEANS OF HIS CHOICE TO ASSURE PROPER ALIGNMENT OF THE 36"Ø PILE RELATIVE TO THE 60"Ø PILE.

MIN. TIP ELEVATION SEE SPECIAL PROVISIONS

OPEN END WITH CUTTING SHOE, SEE PILE TIP DETAIL ON THIS SHEET.

FIELD SPlice LOCATION (PER CONTRACTOR) FOR FIT UP SEE DETAIL W

MIN. TIP ELEVATION SEE SPECIAL PROVISIONS

OPEN END WITH CUTTING SHOE, SEE PILE TIP DETAIL ON THIS SHEET.

TYPICAL PILE ELEVATION

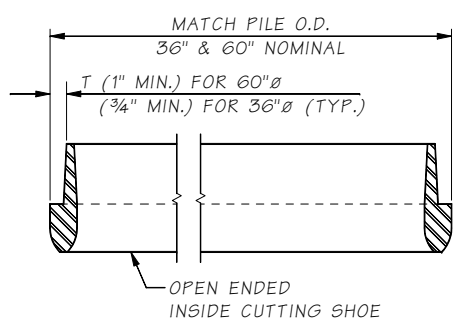
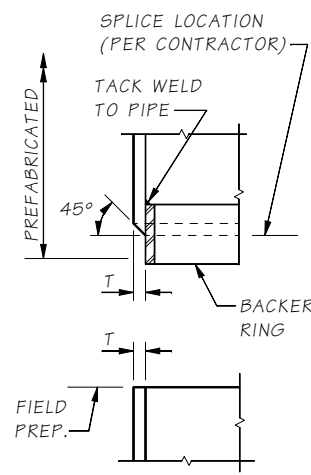
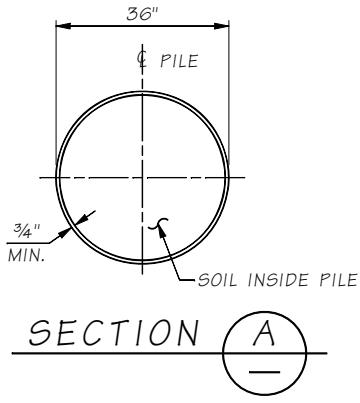

PILE TIP DETAIL

STEEL PILE WALL THICKNESS (T) AND CUTTING SHOE THICKNESS SHALL BE DETERMINED BY CONTRACTOR. SEE STD. SPEC. 6-05.3(B)

DETAIL W

PERMISSIBLE WELD SPlice DETAILS FOR STEEL PIPE PILES. SEE "100% U.T. INSPECTION LIMITS" ON THIS SHEET FOR WELDING INSPECTION REQUIREMENTS.

PILE BAR LIST

ALL REINFORCING SHALL BE ASTM A 706

PIER	PILES REQUIRED PER PIER	MARK	BAR SIZE	BARS PER PILE	LENGTH PER PILE	BEND TYPE	WT. (LBS.) PER PILE
15	4	A	#11	22	29'-1"	STRAIGHT	3,400
		B	#11	22	71'-8"	STRAIGHT	8,377
		C	#5	1	(a)	SPIRAL	195
		D	#5	1	(a)	SPIRAL	751
		E	#5	1	(a)	SPIRAL	1592
TOTAL							14,315

(a) ~ DETERMINED FROM PLANS



SPIRAL

WEIGHT INCLUDES SPLICES.

SR 99 FILE NO. SHEET BG026

Bridge Design Engr. Khaleghi, B	M:\Y-Team\AWV SOUTH INTERCHANGE\window files\Pier 1s Pile Dtls.WND		REGION NO.	STATE	FED. AID PROJ. NO.	SHEET NO.	TOTAL SHEETS
Supervisor Moore, TM			10	WASH.			
Designed By Schultz, E	09/09						
Checked By Lee, CS	09/09						
Detailed By Hanson, CE	09/09						
Bridge Projects Engr.							
Prelim. Plan By	2/17/10	REVISED SHEET	EHS	TMM			
Architect/Specialist		REVISION	BY	APPD			



BRIDGE AND STRUCTURES OFFICE

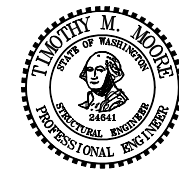

SR 99
 ALASKAN WAY VIADUCT - REPLACEMENT
 S HOLGATE ST TO S KING ST - PHASE 2
 BRIDGE NO. 99/540 NB & SB
 PIER 15 PILE DETAILS

BRIDGE SHEET NO. BG026
 SHEET 872 OF 1475 SHEETS

SR 99 FILE NO. SHEET BG027

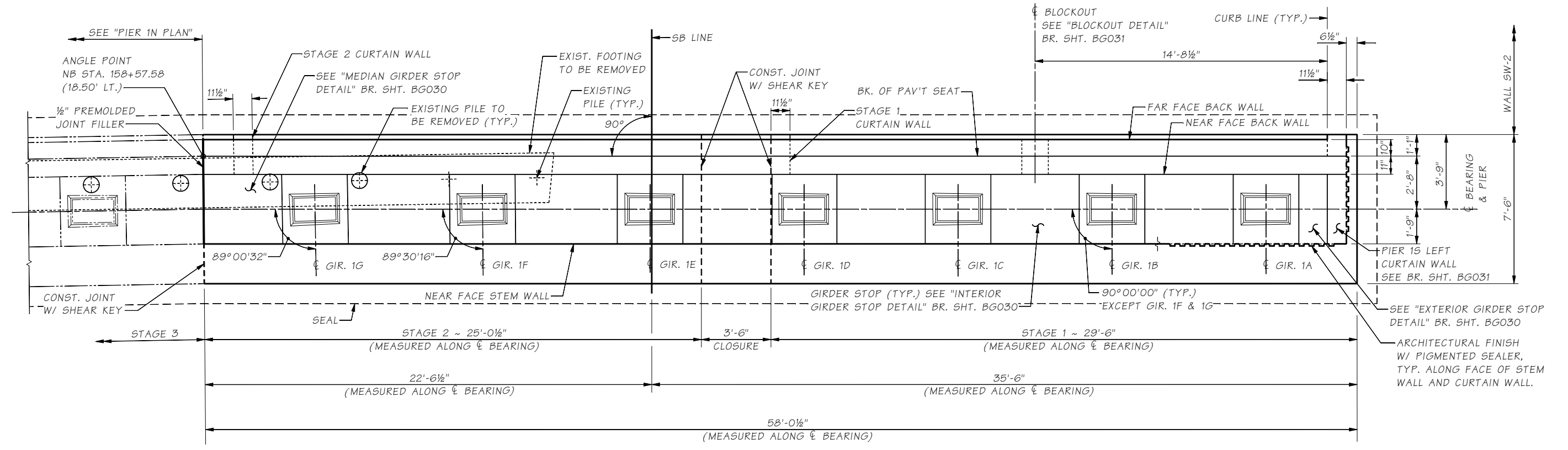

NOTE:
SEE FRAMING PLAN FOR GIRDER SPACING.

PLAN - PIER 15
LOOKING BACK ON STATIONING

Bridge Design Engr.	Khaleghi, B	M:\Y-Team\AWV SOUTH INTERCHANGE\window files\Pier 1s Plan.WND				
Supervisor	Moore, TM	REGION NO.	STATE	FED. AID PROJ. NO.	SHEET NO.	TOTAL SHEETS
Designed By	Schultz, E	10	WASH.			
Checked By	Lee, CS	JOB NUMBER				
Detailed By	Hanson, CE	09A803				
Bridge Projects Engr.		DATE	REVISION	BY	APPD	
Prelim. Plan By						
Architect/Specialist						



BRIDGE AND STRUCTURES OFFICE

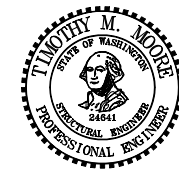

SR 99
 ALASKAN WAY VIADUCT - REPLACEMENT
 S HOLGATE ST TO S KING ST - PHASE 2
 BRIDGE NO. 99/540 NB & SB
 PIER 15 PLAN

BRIDGE SHEET NO. BG027
 SHEET 873 OF 1475 SHEETS

TOP OF GROUT PAD ELEVATIONS							
GIRDER	1A	1B	1C	1D	1E	1F	1G
ELEVATION	33.85	33.75	33.65	33.55	33.45	33.34	33.23

NOTE:
ALL ELEVATIONS ARE AT CENTERLINE BEARING,
EXCEPT THOSE MARKED WITH AN ASTERISK (*)
WHICH ARE AT BACK OF PAVEMENT SEAT.

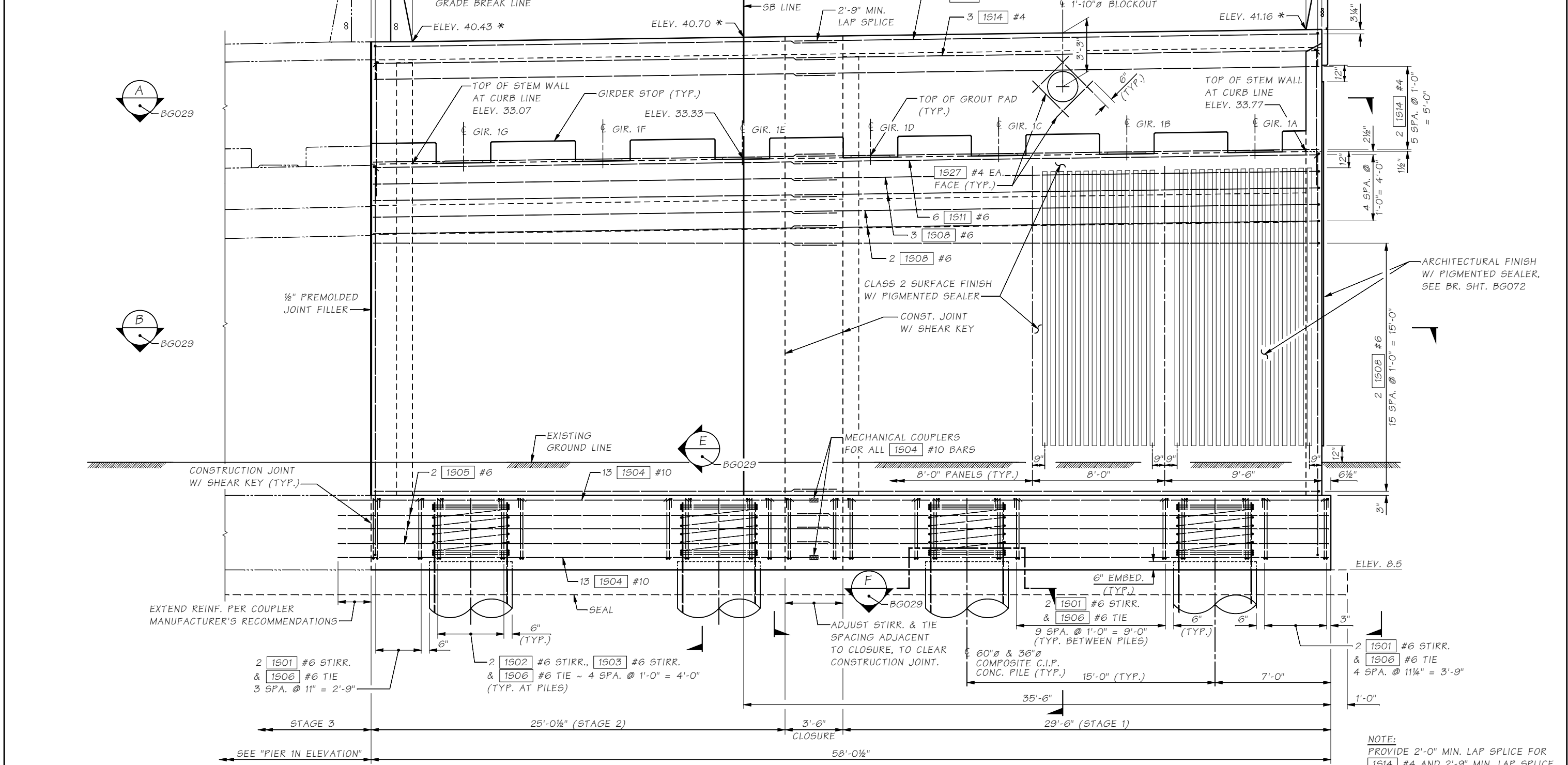

ELEVATION - PIER 15
LOOKING BACK ON STATIONING (CURTAIN WALL REINF. NOT SHOWN)

NOTE:
PROVIDE 2'-0" MIN. LAP SPLICE FOR
[1514] #4 AND 2'-9" MIN. LAP SPLICE
FOR [1508] #6, & [1505] #6 BARS
IN CLOSURE.

SR 99 FILE NO. SHEET BG028

Bridge Design Engr. Khaleghi, B	M:\Y-Team\AWV SOUTH INTERCHANGE\window files\Pier 1s Elevation.WND				
Supervisor Moore, TM	REGION NO.	STATE	FED. AID PROJ. NO.	SHEET NO.	TOTAL SHEETS
Designed By Schultz, E 09/09	10	WASH.			
Checked By Lee, CS 09/09	JOB NUMBER 09A803				
Detailed By Hanson, CE 09/09					
Bridge Projects Engr.					
Prelim. Plan By	2/17/10	REVISED SHEET	CSL	TMM	
Architect/Specialist	DATE	REVISION	BY	APPD	



BRIDGE AND STRUCTURES OFFICE



SR 99
ALASKAN WAY VIADUCT - REPLACEMENT
S HOLGATE ST TO S KING ST - PHASE 2
BRIDGE NO. 99/540 NB & SB
PIER 15 ELEVATION

BRIDGE SHEET NO. BG028
SHEET 874 OF 1475 SHEETS

* 1/2" PREMOLDED JOINT FILLER

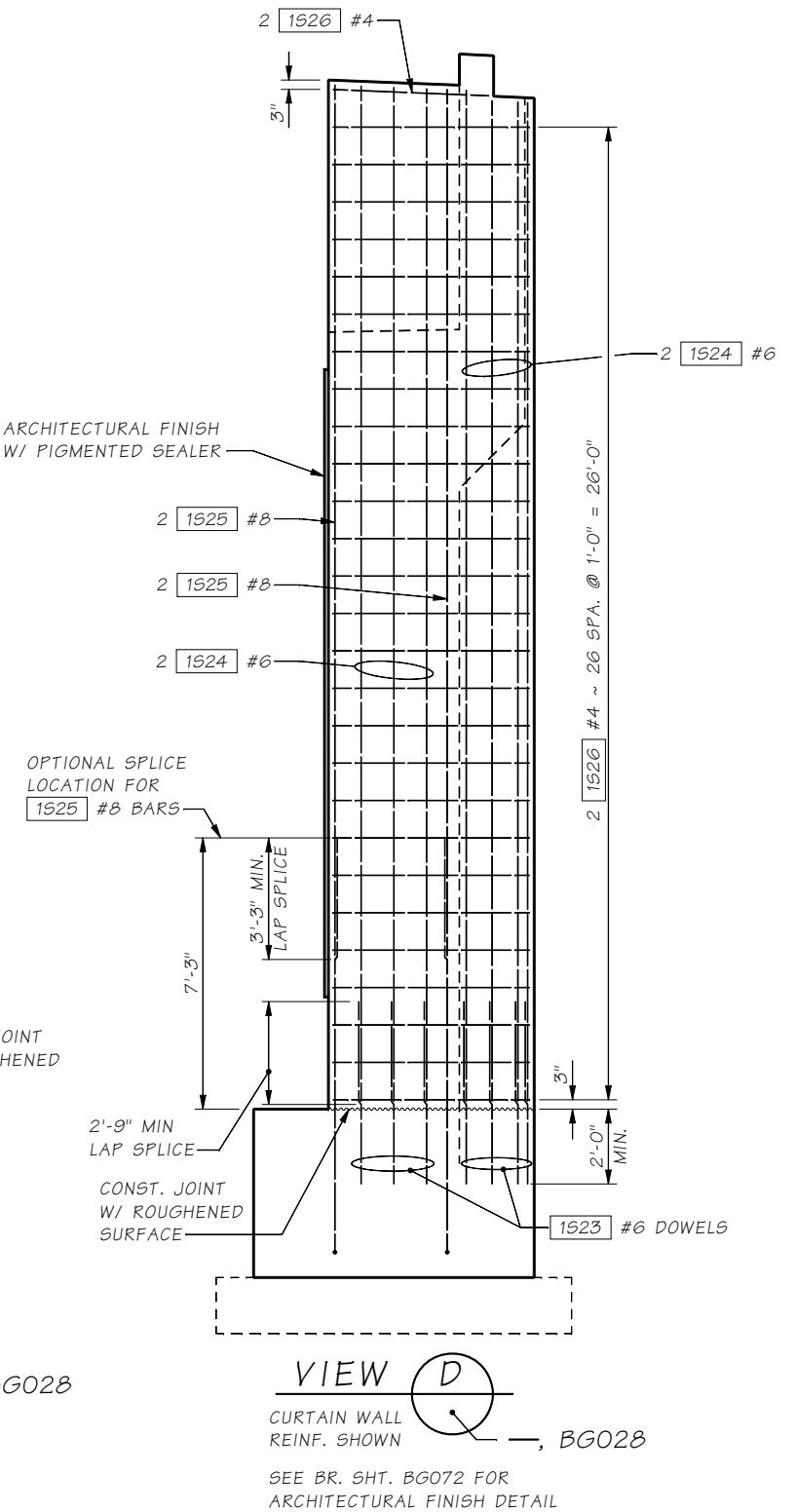
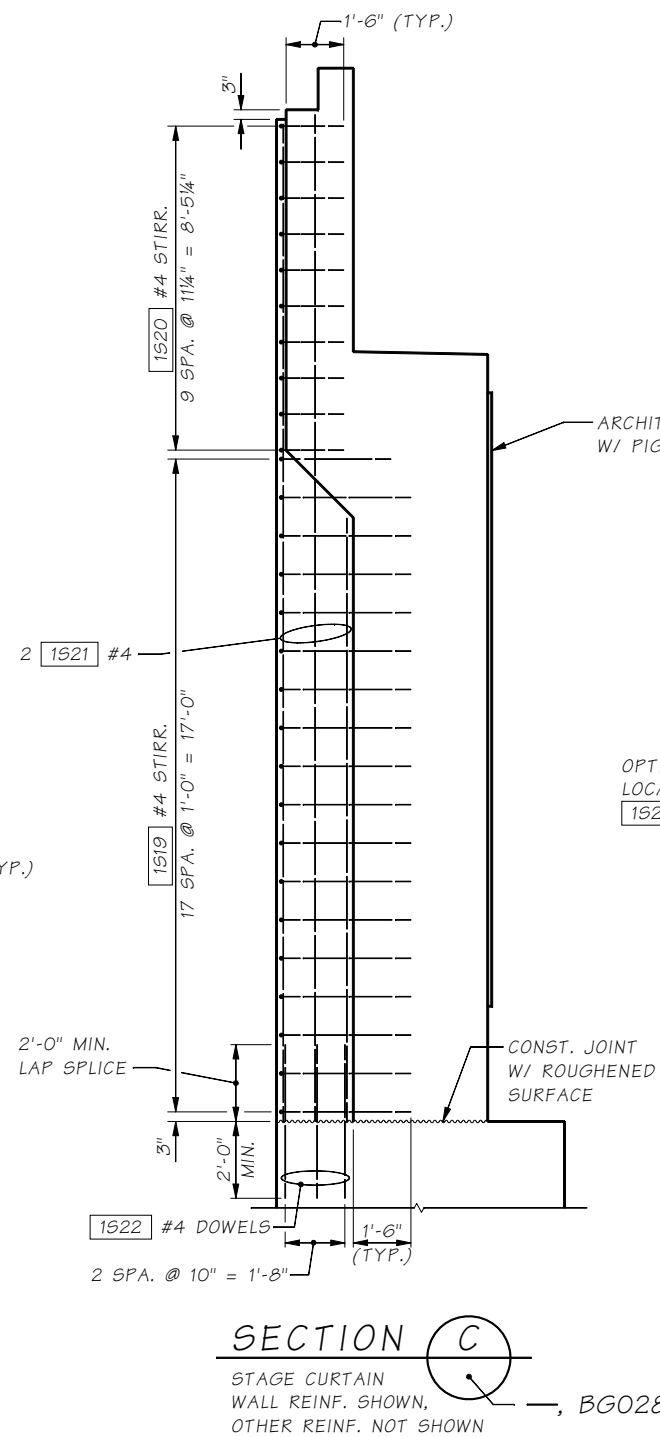
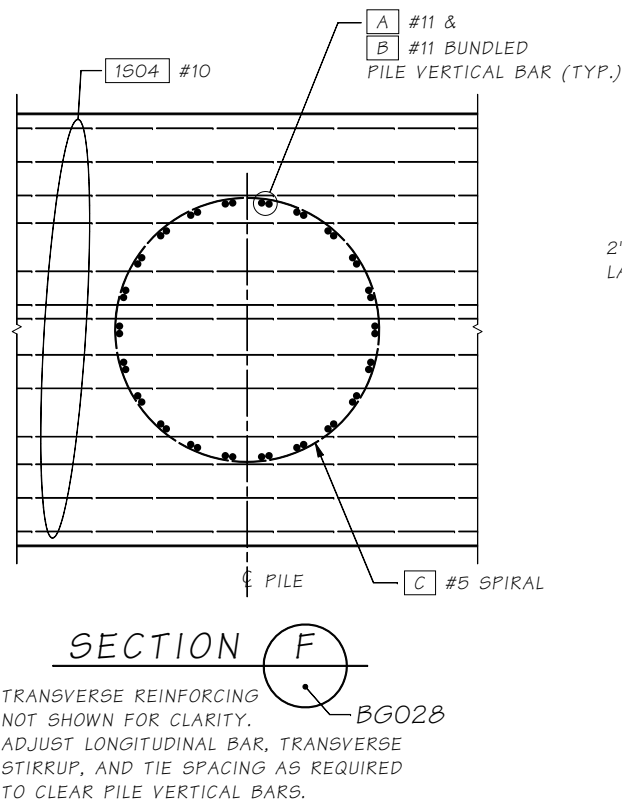
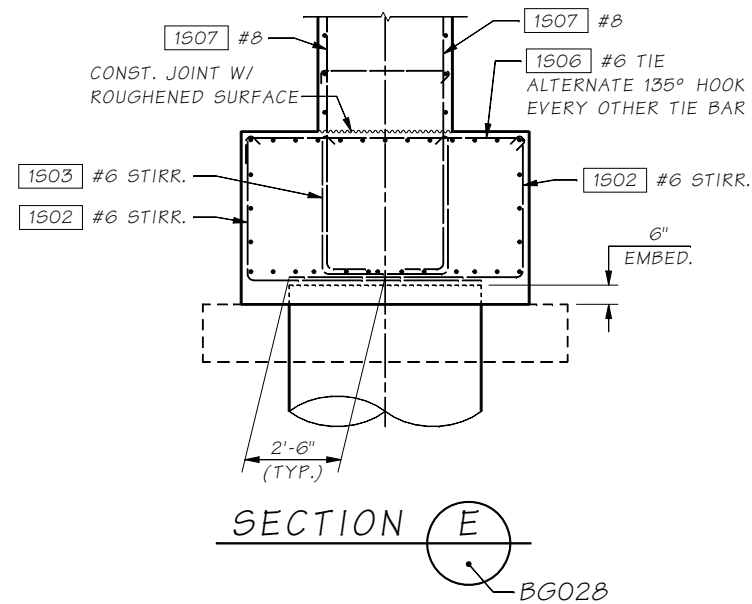
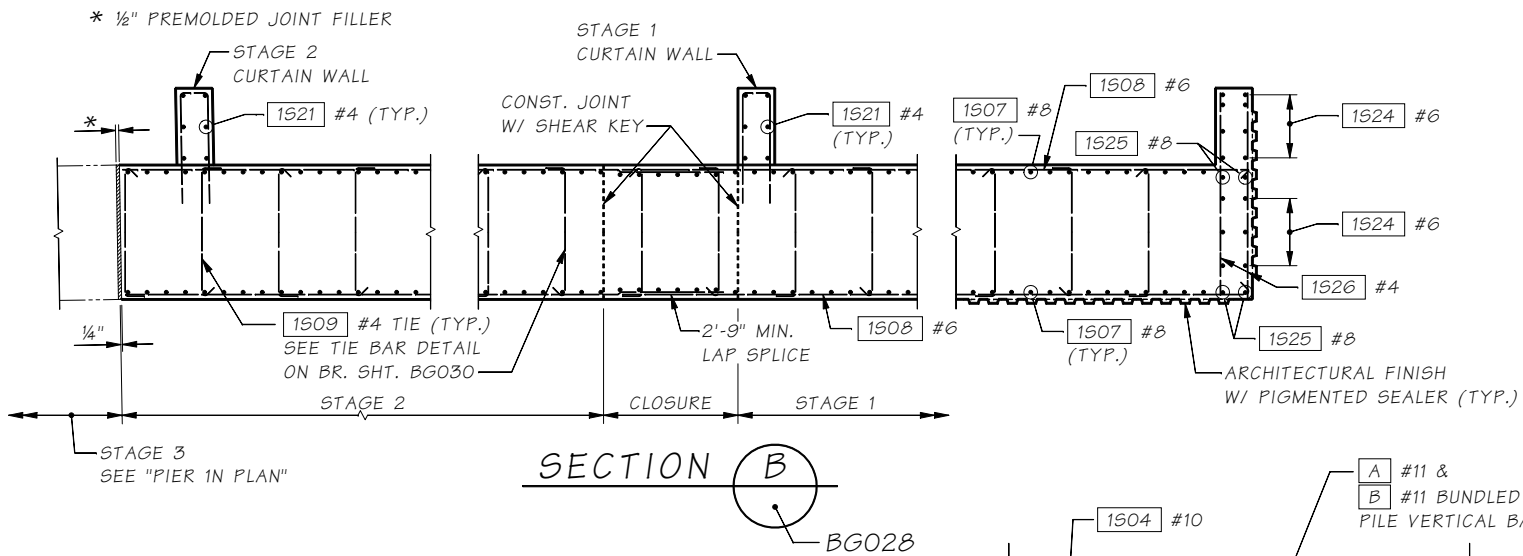
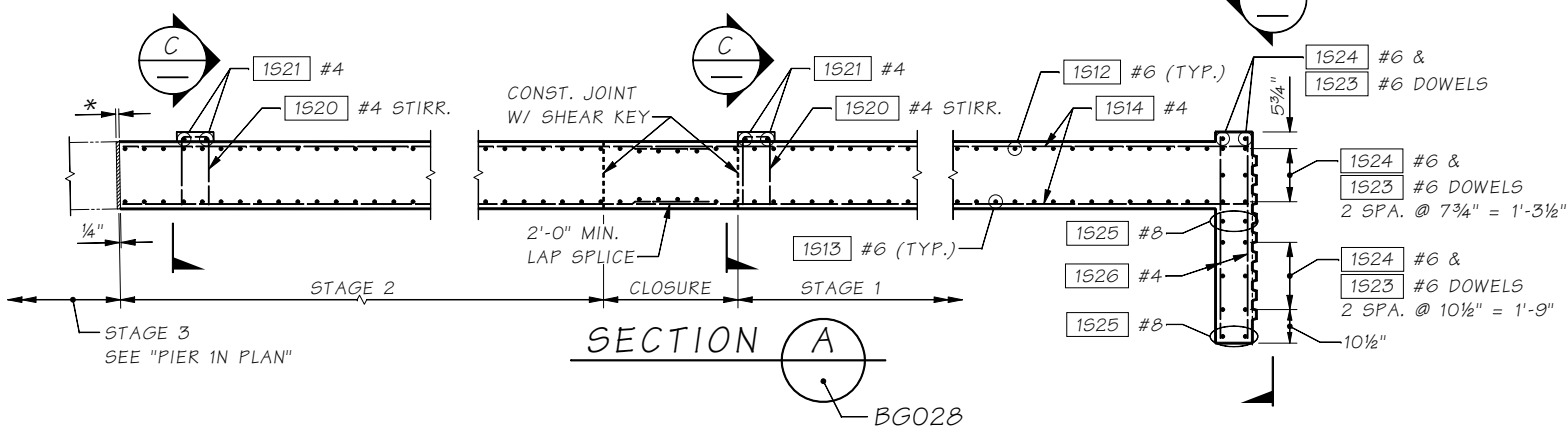

SR 99 FILE NO. SHEET BG029

Bridge Design Engr.	Khaleghi, B	M:\Y-Team\AWV SOUTH INTERCHANGE\window files\Pier 1s Section.WND			
Supervisor	Moore, TM	REGION NO.	STATE	FED. AID PROJ. NO.	SHEET NO.
Designed By	Schultz, E 09/09	10	WASH.		TOTAL SHEETS
Checked By	Lee, CS 09/09	JOB NUMBER 09A803			
Detailed By	Hanson, CE 09/09				
Bridge Projects Engr.					
Prelim. Plan By					
Architect/Specialist		DATE	REVISION	BY	APPD



BRIDGE AND STRUCTURES OFFICE

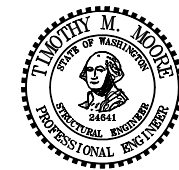

SR 99
ALASKAN WAY VIADUCT - REPLACEMENT
S HOLGATE ST TO S KING ST - PHASE 2
BRIDGE NO. 99/540 NB & SB
PIER 15 SECTION

BRIDGE SHEET NO. BG029
SHEET 875 OF 1475 SHEETS

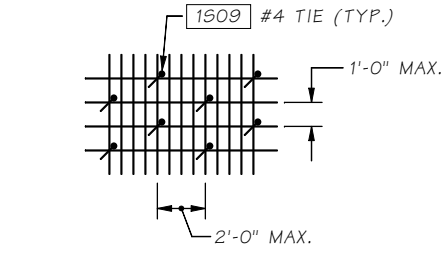
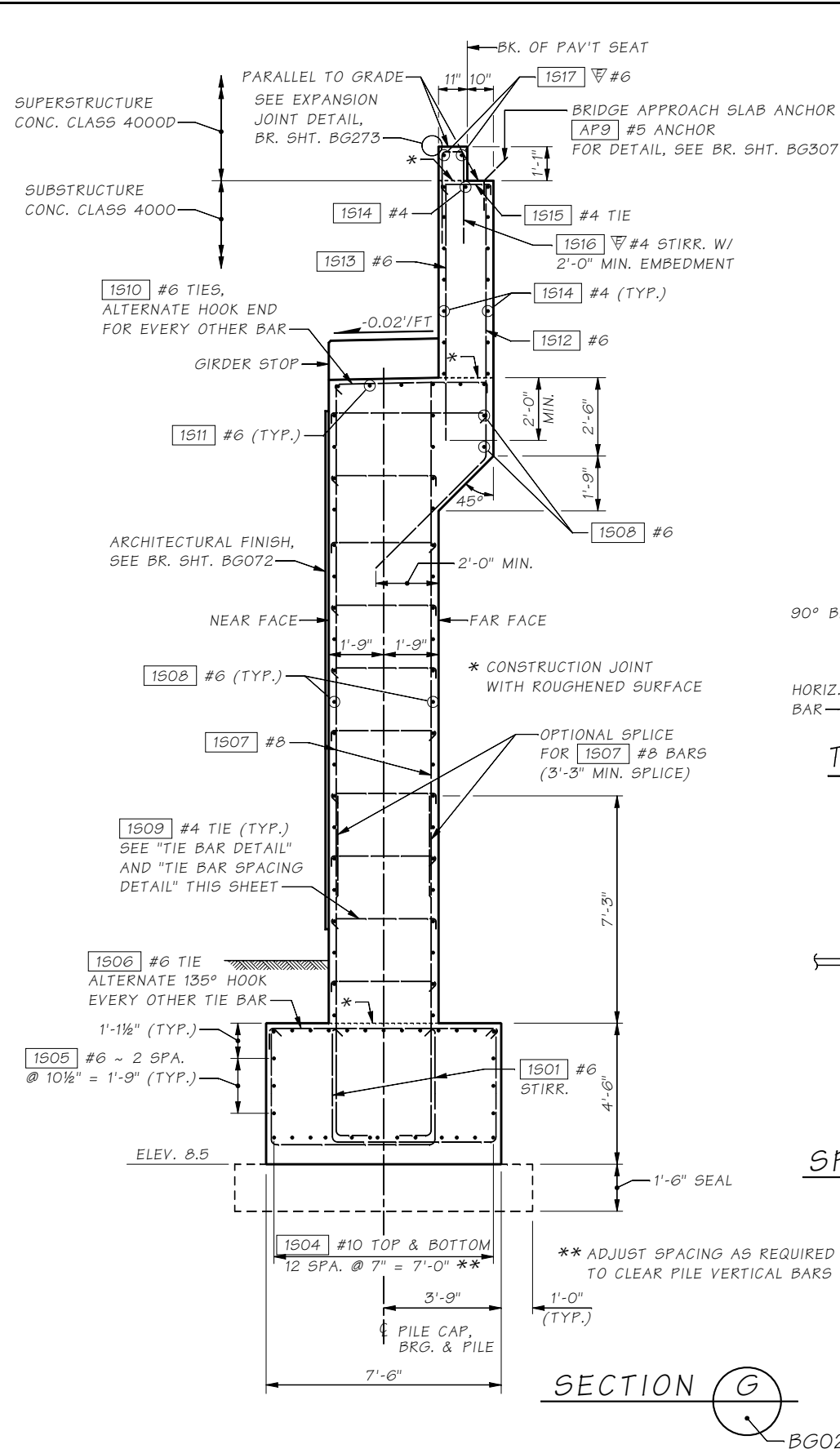

TIE BAR SPACING DETAIL

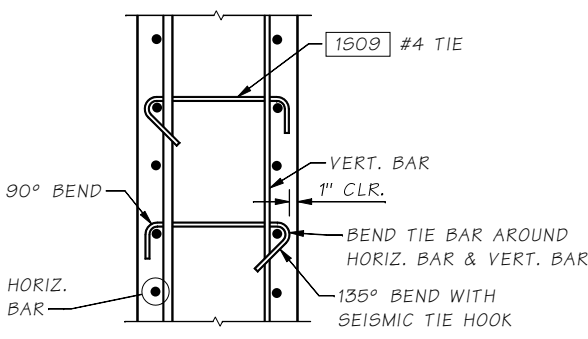

TIE BAR DETAIL
ALTERNATE 135° HOOK EVERY OTHER TIE BAR

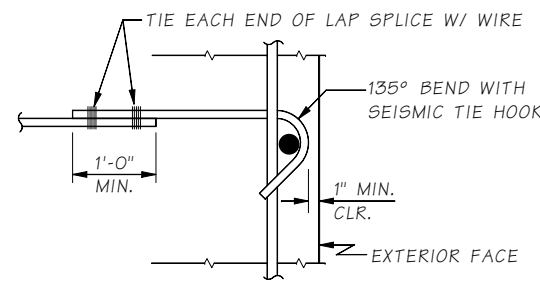

TIE BAR SPLICE DETAIL OPTION

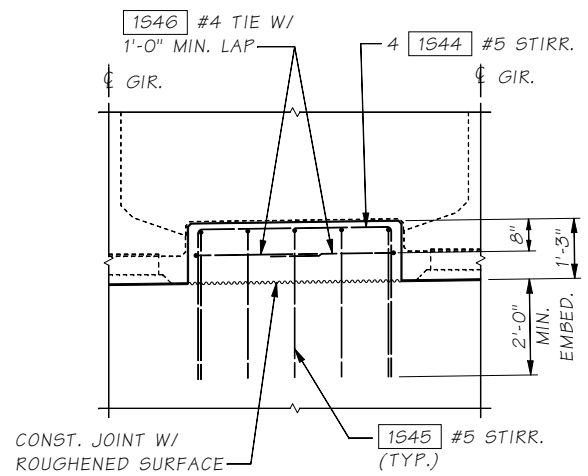

SECTION A

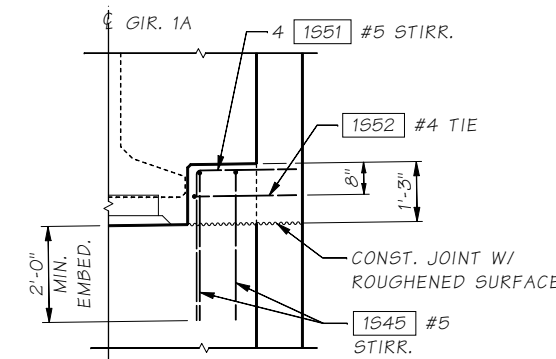

SECTION B

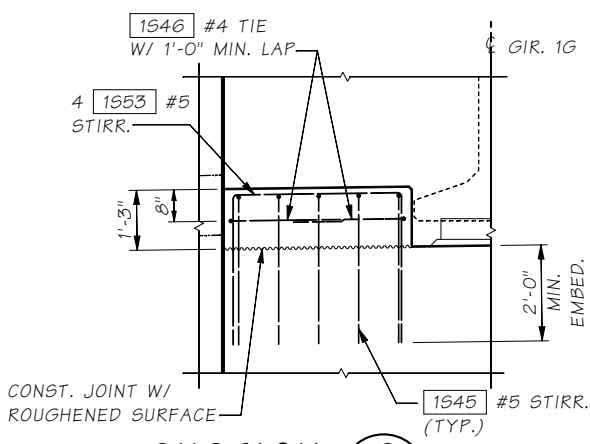

SECTION C

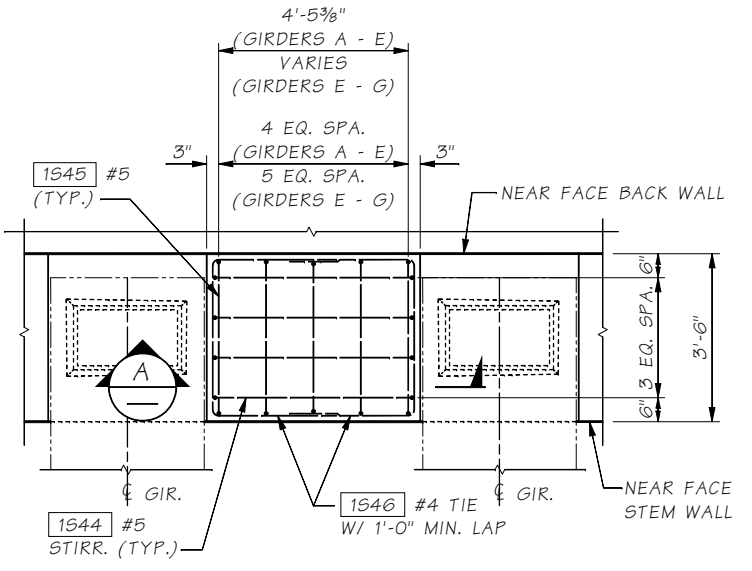

INTERIOR GIRDER STOP DETAIL

NOTE: SEE "GIRDER SEAT DETAIL" BR. SHT. BG142 FOR ADDITIONAL INFORMATION.

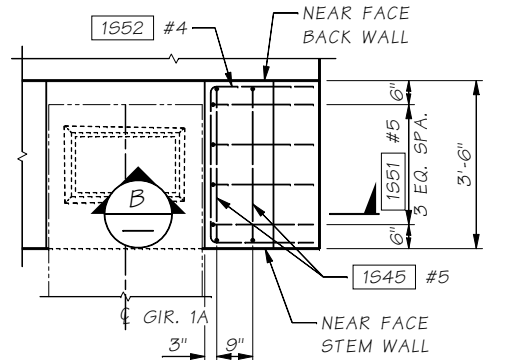

EXTERIOR GIRDER STOP DETAIL

CURTAIN WALL REINF. NOT SHOWN FOR CLARITY.

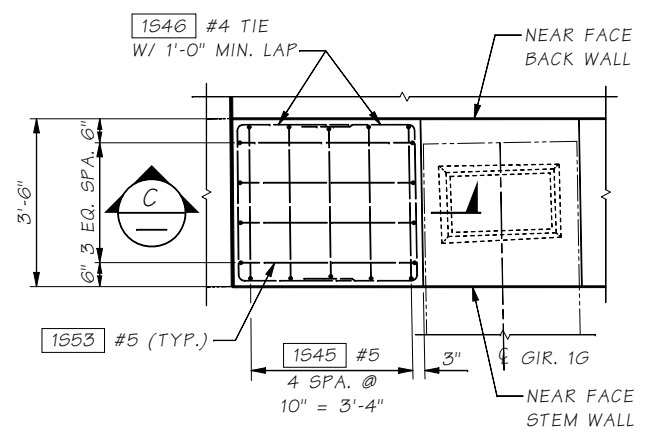

MEDIAN GIRDER STOP DETAIL

SR 99 FILE NO. SHEET BG030

Bridge Design Engr.	Khaleghi, B	M:\Y-Team\AWV SOUTH INTERCHANGE\window files\Pier 1s Details.WND	REGION NO.	STATE	FED. AID PROJ. NO.	SHEET NO.	TOTAL SHEETS
Supervisor	Moore, TM		10	WASH.			
Designed By	Schultz, E	09/09					
Checked By	Lee, CS	09/09					
Detailed By	Hanson, CE	09/09					
Bridge Projects Engr.			JOB NUMBER				
Prelim. Plan By			09A803				
Architect/Specialist		DATE	REVISION	BY	APPD		



BRIDGE AND STRUCTURES OFFICE



SR 99
ALASKAN WAY VIADUCT - REPLACEMENT
S HOLGATE ST TO S KING ST - PHASE 2
BRIDGE NO. 99/540 NB & SB
PIER 15 DETAILS

BRIDGE SHEET NO. BG030
SHEET 876 OF 1475 SHEETS

TABLE OF ELEVATIONS *		
PIER	ELEV. A	ELEV. B
PIER 15 (LEFT)	40.53	40.38

* AT EXTERIOR FACE OF CURTAIN WALL

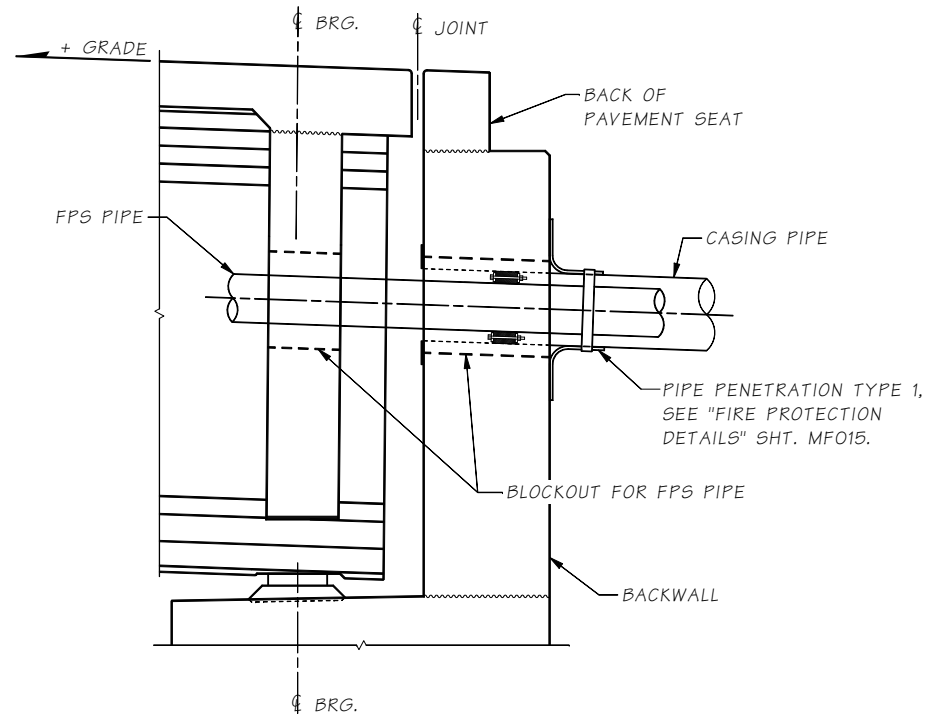
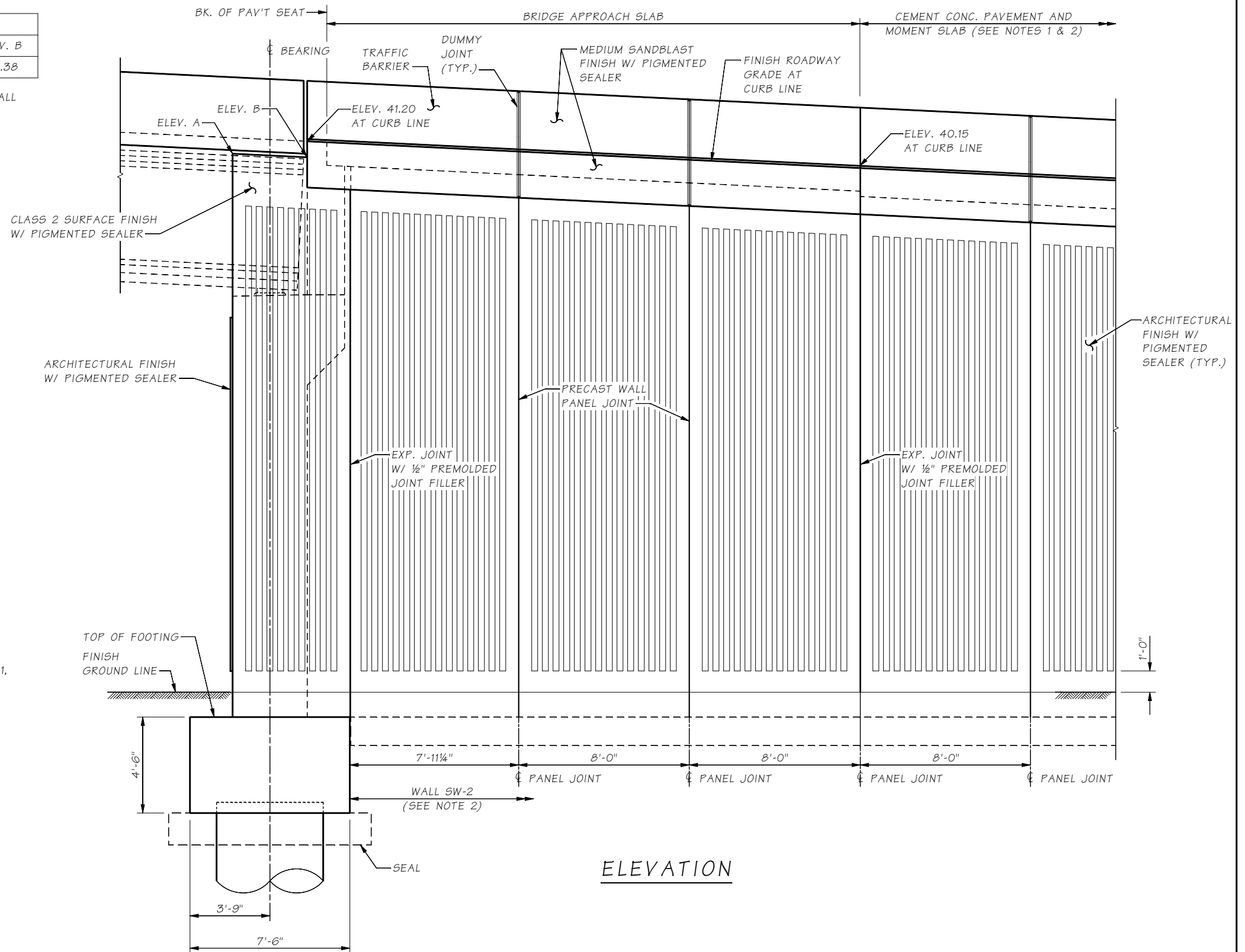

BLOCKOUT DETAIL

ELEVATION

NOTES:

1. SEE "PAVING PLANS" AND "ROADWAY SECTIONS" FOR DETAILS.
2. SEE SL SERIES FOR WALL PLAN, ELEVATION AND SECTION DETAILS.

SR 99 FILE NO. SHEET BG031

Bridge Design Engr.	Khaleghi, B	M:\Y-Team\AWV SOUTH INTERCHANGE\window files\Pier 15 Curtain wall.WND			
Supervisor	Moore, TM	REGION NO.	STATE	FED. AID PROJ. NO.	SHEET NO.
Designed By	Schultz, E 09/09	10	WASH.		TOTAL SHEETS
Checked By	Lee, CS 09/09	JOB NUMBER			
Detailed By	Hanson, CE 09/09	09A803			
Bridge Projects Engr.		DATE	REVISION	BY	APPD
Prelim. Plan By		2/17/10	REVISED SHEET	CSL	TMM
Architect/Specialist					



BRIDGE AND STRUCTURES OFFICE

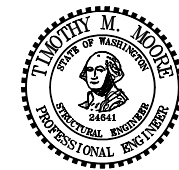

SR 99
ALASKAN WAY VIADUCT - REPLACEMENT
S HOLGATE ST TO S KING ST - PHASE 2
BRIDGE NO. 99/540 NB & SB

PIER 15 CURTAIN WALL ELEVATION

BRIDGE SHEET NO. BG031
SHEET 877 OF 1475 SHEETS

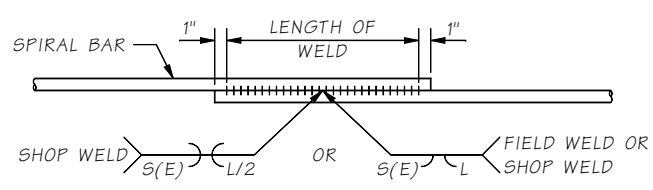
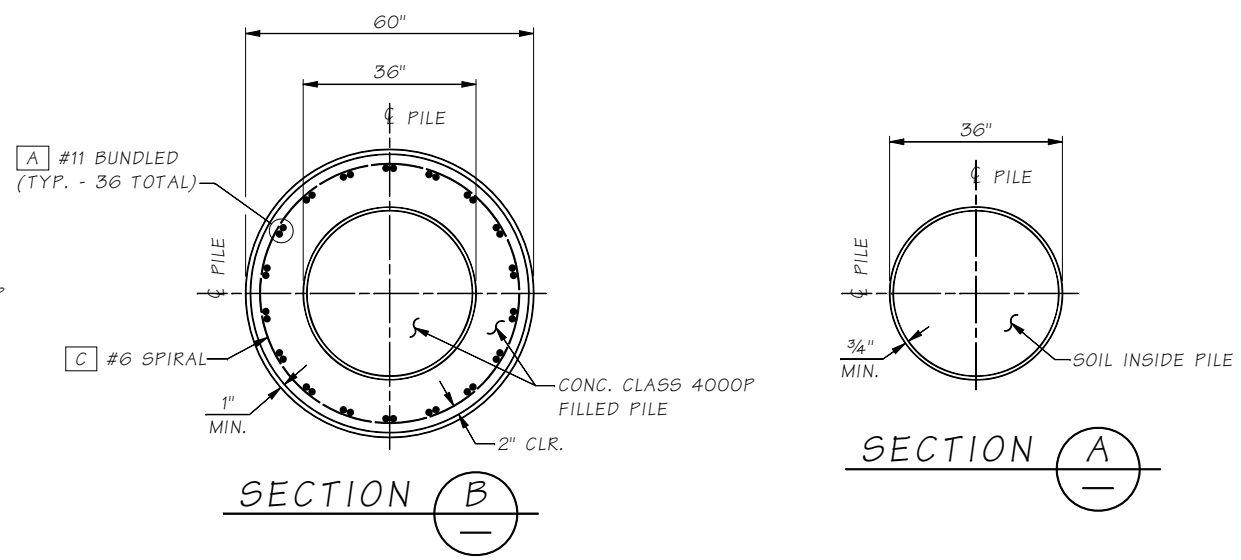
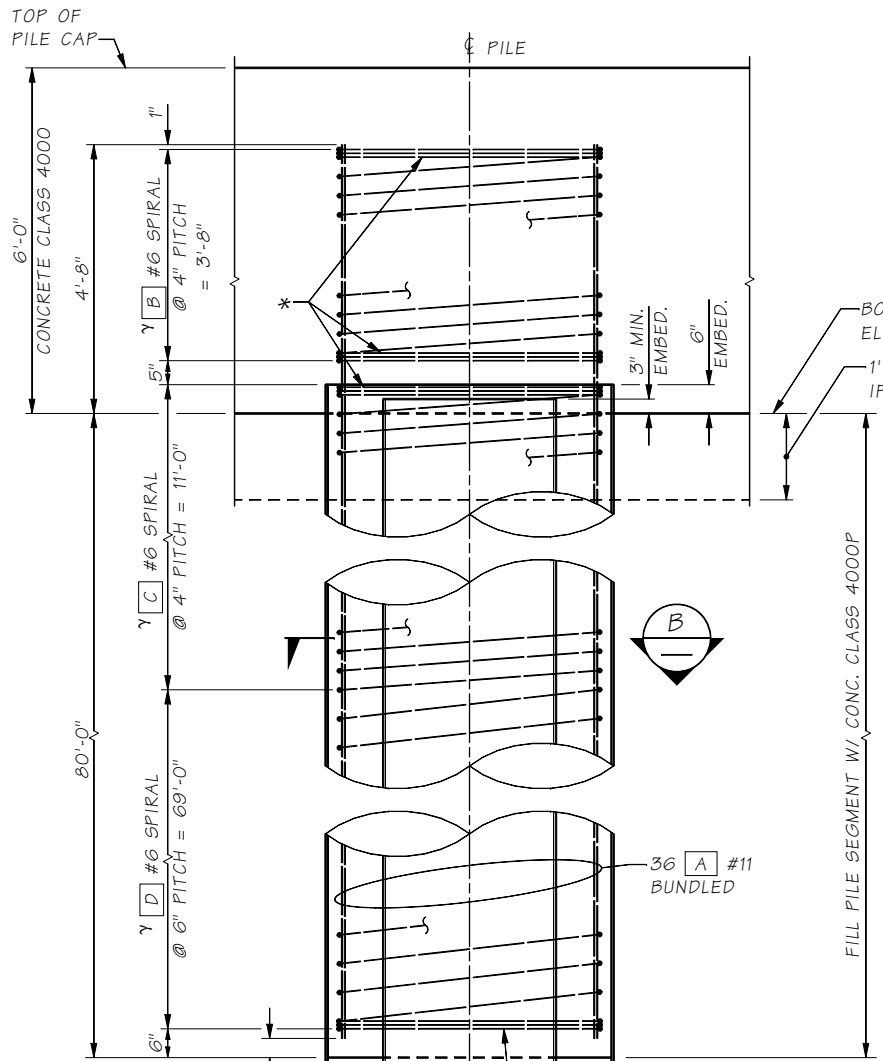

WELDED LAP SPLICE DETAIL
 WELDING SHALL MEET THE REQUIREMENTS OF STD. SPEC. 6-02.3(24)E FOR WELD DIMENSIONS, SEE TABLE BELOW.

DEFORMED BAR	WELD DIMENSIONS		
	S	E	LENGTH (L)
#6	3/8	3/16	6"

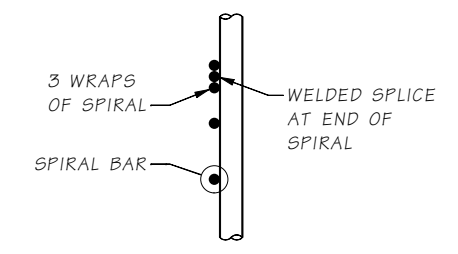

SPIRAL TERMINATION DETAIL

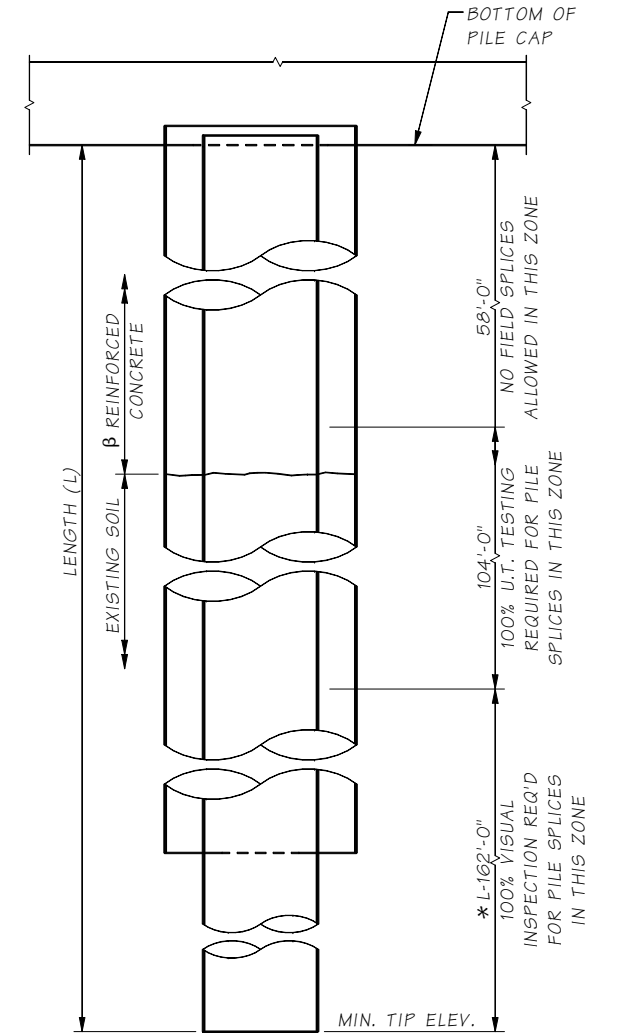

100% U.T. INSPECTION LIMITS

* ALL FIELD SPLICES FOR TEST PILE REQUIRE 100% U.T. TESTING
 B SEE "TYPICAL PILE ELEVATION" ON THIS SHEET FOR REINFORCING DETAILS.

NOTE:
 DURING DRIVING OF 36"Ø PILE INSIDE THE 60"Ø PILE, THE CONTRACTOR SHALL PROVIDE A MANDREL OR SOME MEANS OF HIS CHOICE TO ASSURE PROPER ALIGNMENT OF THE 36"Ø PILE RELATIVE TO THE 60"Ø PILE.

* SEE SPIRAL TERMINATION DETAIL ON THIS SHEET.
 γ WELDED SPLICE ONLY (SEE WELDED LAP SPLICE DETAIL ON THIS SHEET)

MIN. TIP ELEVATION SEE SPECIAL PROVISIONS
 OPEN END WITH CUTTING SHOE, SEE "PILE TIP DETAIL" ON THIS SHEET
 FIELD SPLICE LOCATION (PER CONTRACTOR) FOR FIT UP SEE DETAIL (W)
 MIN. TIP ELEVATION SEE SPECIAL PROVISIONS
 OPEN END WITH CUTTING SHOE, SEE "PILE TIP DETAIL" ON THIS SHEET.

TYPICAL PILE ELEVATION

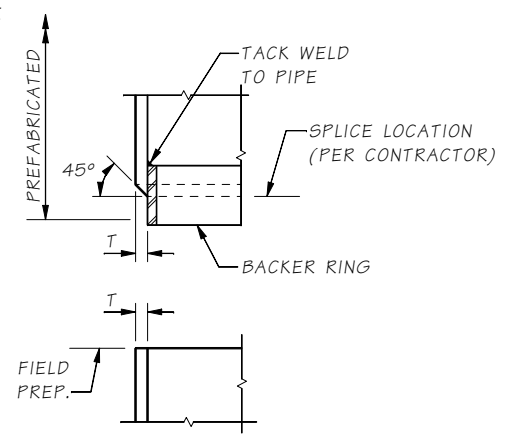

DETAIL W
 PERMISSIBLE WELD SPLICE DETAILS FOR STEEL PIPE PILES. SEE 100% U.T. INSPECTION LIMITS ON THIS SHEET FOR WELDING INSPECTION REQUIREMENTS.

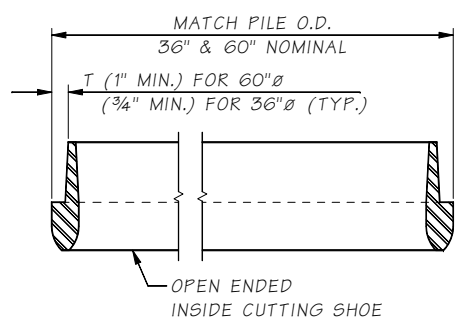

PILE TIP DETAIL
 STEEL PILE WALL THICKNESS (T) AND CUTTING SHOE THICKNESS SHALL BE DETERMINED BY CONTRACTOR. SEE STD. SPEC. 6-05.3(B)

PILE BAR LIST
 ALL REINFORCING SHALL BE ASTM A 706

PIER	PILES REQUIRED PER PIER	MARK	BAR SIZE	BARS PER PILE	LENGTH	BEND TYPE	WT. (LBS.) PER PILE
25	B	A	#11	36	84'-4"	STRAIGHT	16,131
		B	#6	1	(a)	SPIRAL	324
		C	#6	1	(a)	SPIRAL	755
		D	#6	1	(a)	SPIRAL	3,022
TOTAL							20,232

(a) ~ DETERMINED FROM PLANS

SPIRAL
 WEIGHT INCLUDES SPLICES.

SR 99 FILE NO. SHEET BG032

Bridge Design Engr. Khaleghi, B	M:\Y-Team\AWV SOUTH INTERCHANGE\window files\Pier 2s Pile Dtls.WND			
Supervisor Moore, TM	REGION NO.	STATE	FED. AID PROJ. NO.	SHEET NO.
Designed By Schultz, E 09/09	10	WASH.		TOTAL SHEETS
Checked By Lee, CS 09/09	JOB NUMBER 09A803			
Detailed By Hanson, CE 09/09				
Bridge Projects Engr.	DATE	REVISION	BY	APPD
Prelim. Plan By	2/17/10	REVISED SHEET	EHS	TMM
Architect/Specialist				



BRIDGE AND STRUCTURES OFFICE

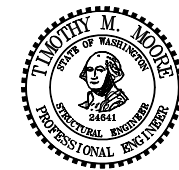

SR 99
 ALASKAN WAY VIADUCT - REPLACEMENT
 S HOLGATE ST TO S KING ST - PHASE 2
 BRIDGE NO. 99/540 NB & SB

PIER 25 PILE DETAILS

BRIDGE SHEET NO. BG032
 SHEET 878 OF 1475 SHEETS

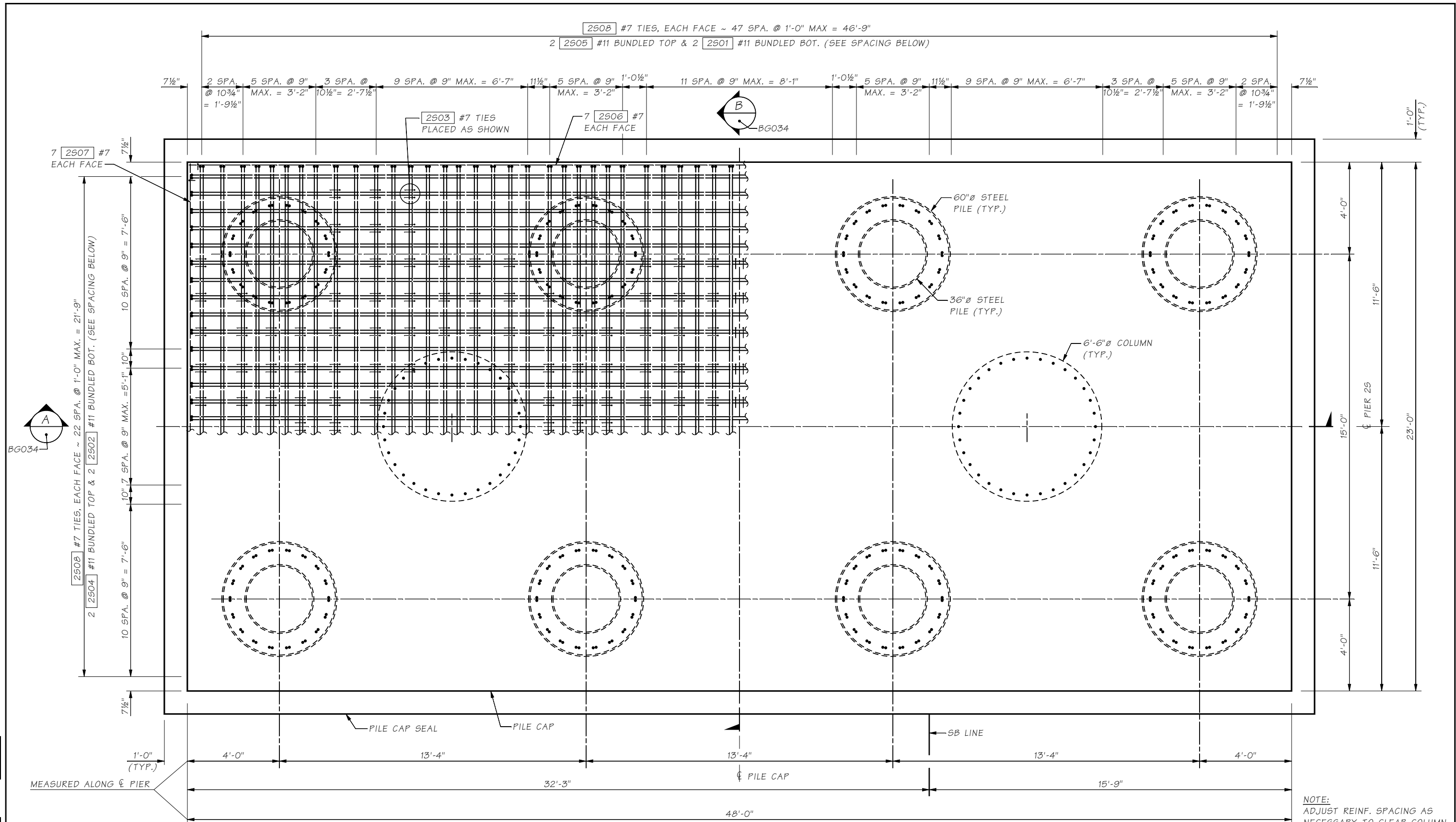

PLAN

NOTE:
ADJUST REINF. SPACING AS NECESSARY TO CLEAR COLUMN AND PILE VERTICAL BARS.

SR 99 FILE NO. SHEET BG033

Bridge Design Engr.	Khaleghi, B	M:\Y-Team\AWV SOUTH INTERCHANGE\window files\Pier 2s Pile Cap Plan.WND			
Supervisor	Moore, TM	REGION NO.	STATE	FED. AID PROJ. NO.	SHEET NO.
Designed By	Schultz, E	10	WASH.		TOTAL SHEETS
Checked By	Lee, CS	JOB NUMBER 09A803			
Detailed By	Hanson, CE				
Bridge Projects Engr.					
Prelim. Plan By					
Architect/Specialist		DATE	REVISION	BY	APPD



BRIDGE AND STRUCTURES OFFICE

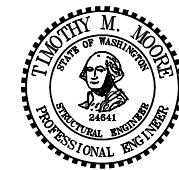

SR 99
ALASKAN WAY VIADUCT - REPLACEMENT
S HOLGATE ST TO S KING ST - PHASE 2
BRIDGE NO. 99/540 NB & SB

PIER 25 PILE CAP PLAN

BRIDGE SHEET NO. BG033
SHEET 879 OF 1475 SHEETS

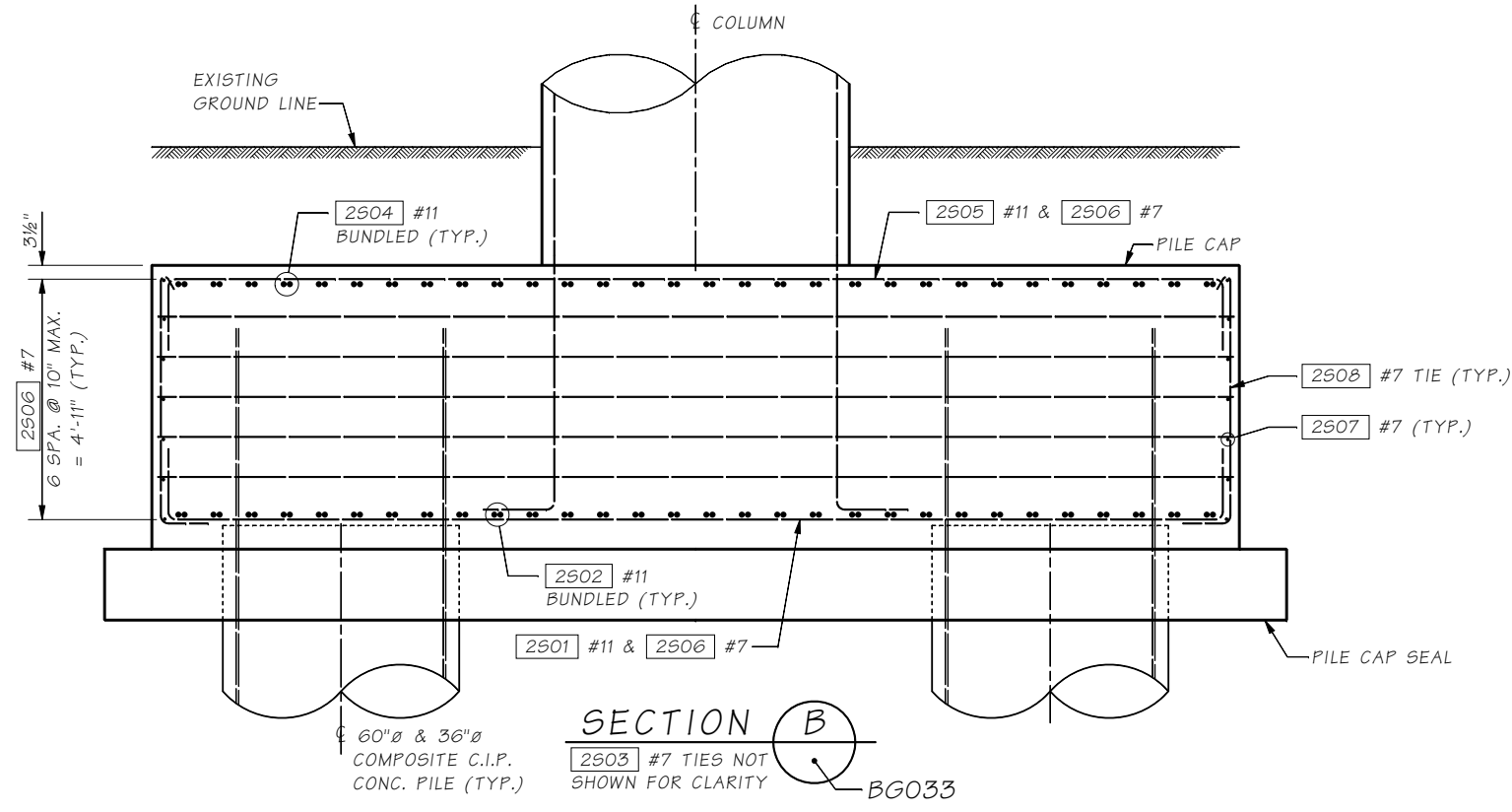

SECTION B
 2503 #7 TIES NOT SHOWN FOR CLARITY
 BG033

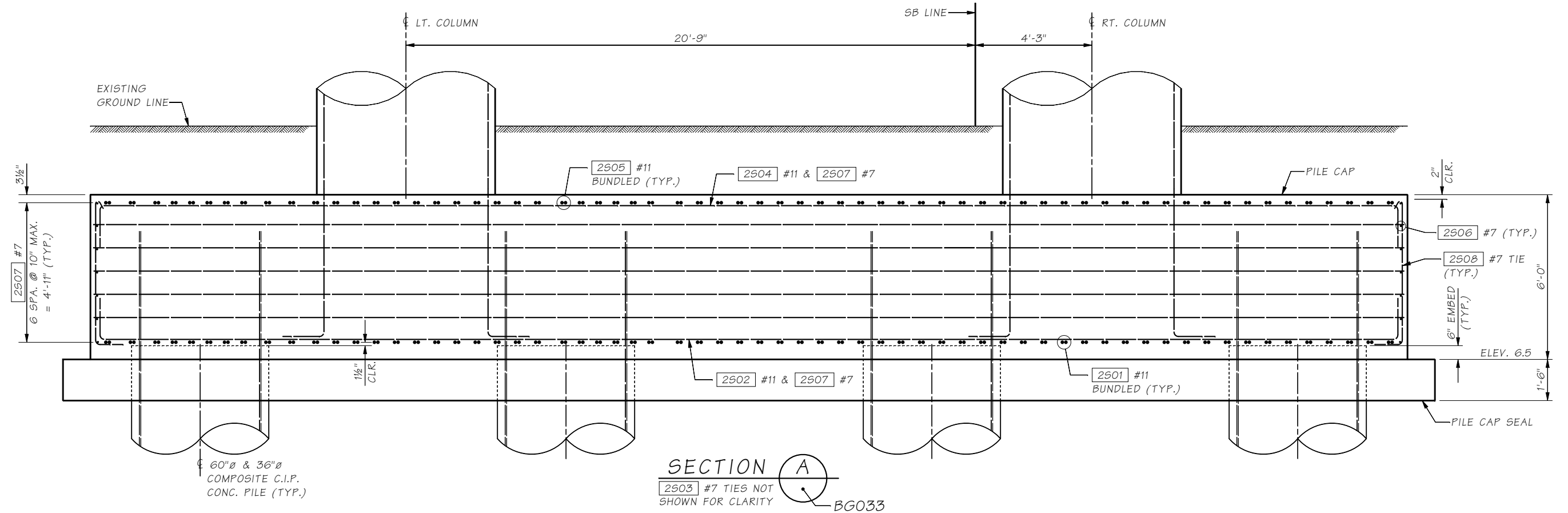

SECTION A
 2503 #7 TIES NOT SHOWN FOR CLARITY
 BG033

SR 99 FILE NO. SHEET BG034

Bridge Design Engr.	Khaleghi, B	M:\Y-Team\AWV SOUTH INTERCHANGE\window files\Pier 2s Pile Cap Elev.WND			
Supervisor	Moore, TM	REGION NO.	STATE	FED. AID PROJ. NO.	SHEET NO.
Designed By	Schultz, E 09/09	10	WASH.		TOTAL SHEETS
Checked By	Lee, CS 09/09	JOB NUMBER 09A803			
Detailed By	Hanson, CE 09/09				
Bridge Projects Engr.		DATE	REVISION	BY	APPD
Prelim. Plan By					
Architect/Specialist					



BRIDGE AND STRUCTURES OFFICE

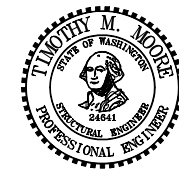

SR 99
ALASKAN WAY VIADUCT - REPLACEMENT
S HOLGATE ST TO S KING ST - PHASE 2
 BRIDGE NO. 99/540 NB & SB
PIER 2S PILE CAP ELEVATION

BRIDGE SHEET NO. **BG034**
 SHEET 880 OF 1475 SHEETS

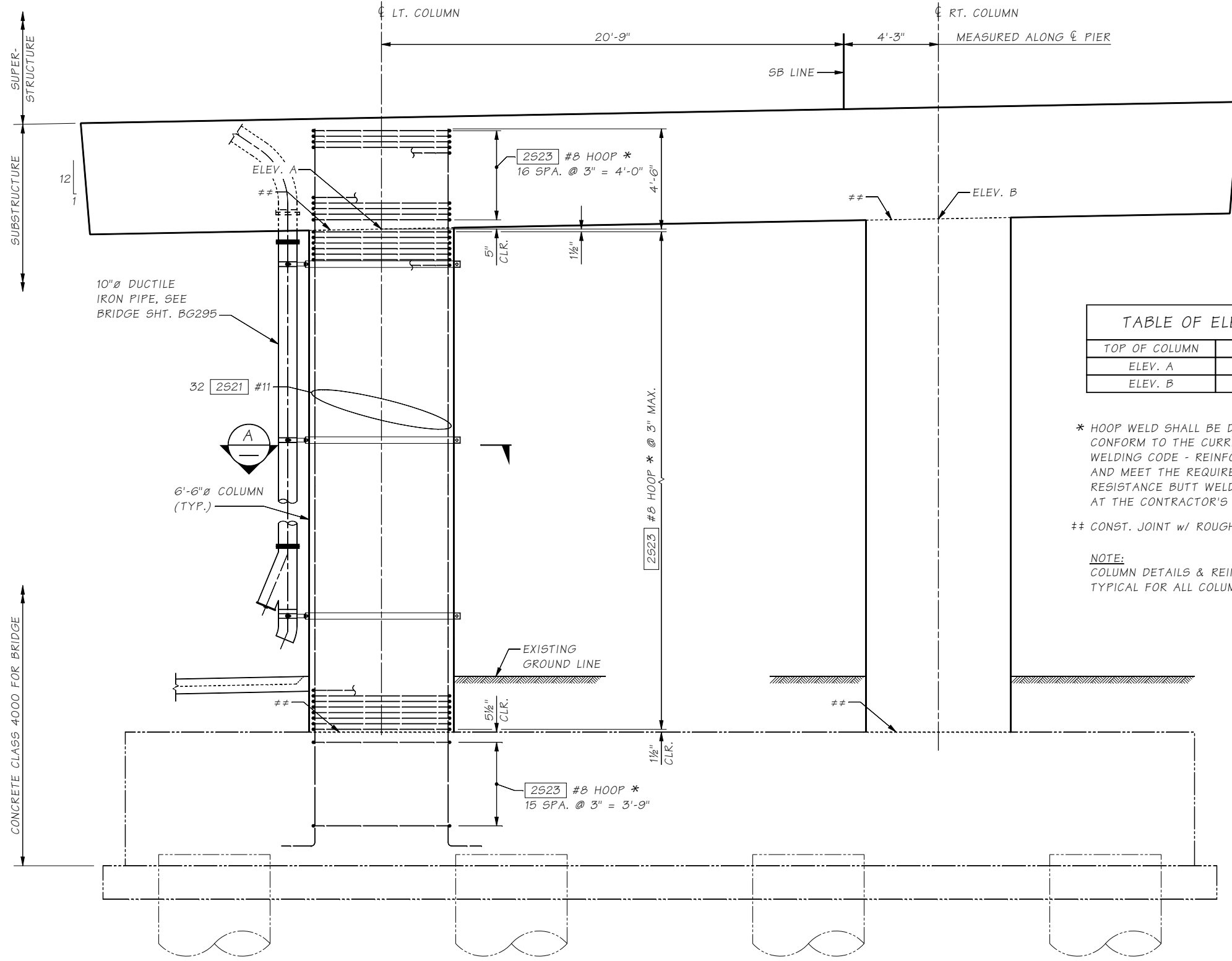

COLUMN ELEVATION - PIER 25

TABLE OF ELEVATIONS	
TOP OF COLUMN	ELEVATION
ELEV. A	35.16
ELEV. B	35.59

* HOOP WELD SHALL BE DIRECT BUTT-WELDED AND CONFORM TO THE CURRENT EDITION OF STRUCTURAL WELDING CODE - REINFORCING STEEL OF AWS(D1.4) AND MEET THE REQUIREMENTS OF STD. SPEC. 6-02.3(24)E. RESISTANCE BUTT WELDED SPLICE MAY BE SUBSTITUTED AT THE CONTRACTOR'S OPTION. SEE SPECIAL PROVISIONS.

CONST. JOINT w/ ROUGHENED SURFACE

NOTE:
COLUMN DETAILS & REINFORCING TYPICAL FOR ALL COLUMNS.

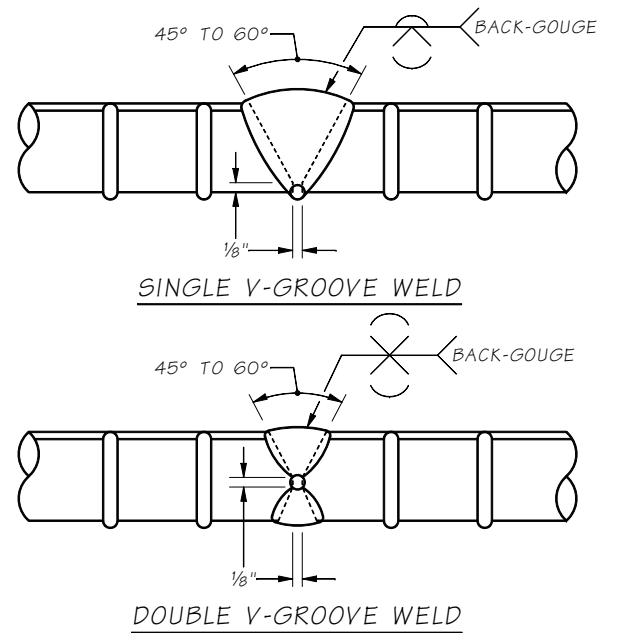
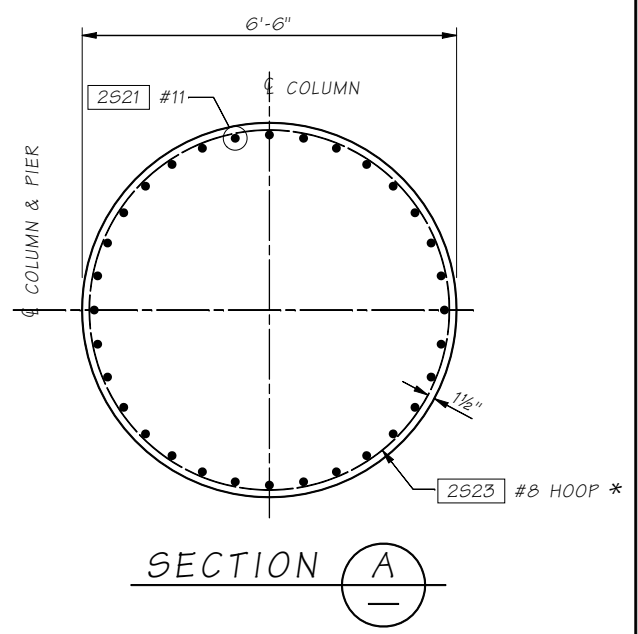

HOOP WELD DETAIL
ALL BACKING SHALL BE REMOVED

SR 99 FILE NO. SHEET BG035

Bridge Design Engr.	Khaleghi, B	M:\Y-Team\AWV SOUTH INTERCHANGE\window files\Pier 2s Col Dtl's.WND			
Supervisor	Moore, TM	REGION NO.	STATE	FED. AID PROJ. NO.	SHEET NO.
Designed By	Lee, CS 09/09	10	WASH.		TOTAL SHEETS
Checked By	Schultz, E 09/09	JOB NUMBER			
Detailed By	Hanson, CE 09/09	09A803			
Bridge Projects Engr.					
Prelim. Plan By					
Architect/Specialist		DATE	REVISION	BY	APPD



BRIDGE AND STRUCTURES OFFICE

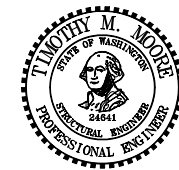

SR 99
ALASKAN WAY VIADUCT - REPLACEMENT
S HOLGATE ST TO S KING ST - PHASE 2
BRIDGE NO. 99/540 NB & SB
PIER 25 COLUMN DETAILS

BRIDGE SHEET NO. BG035
SHEET 881 OF 1475 SHEETS

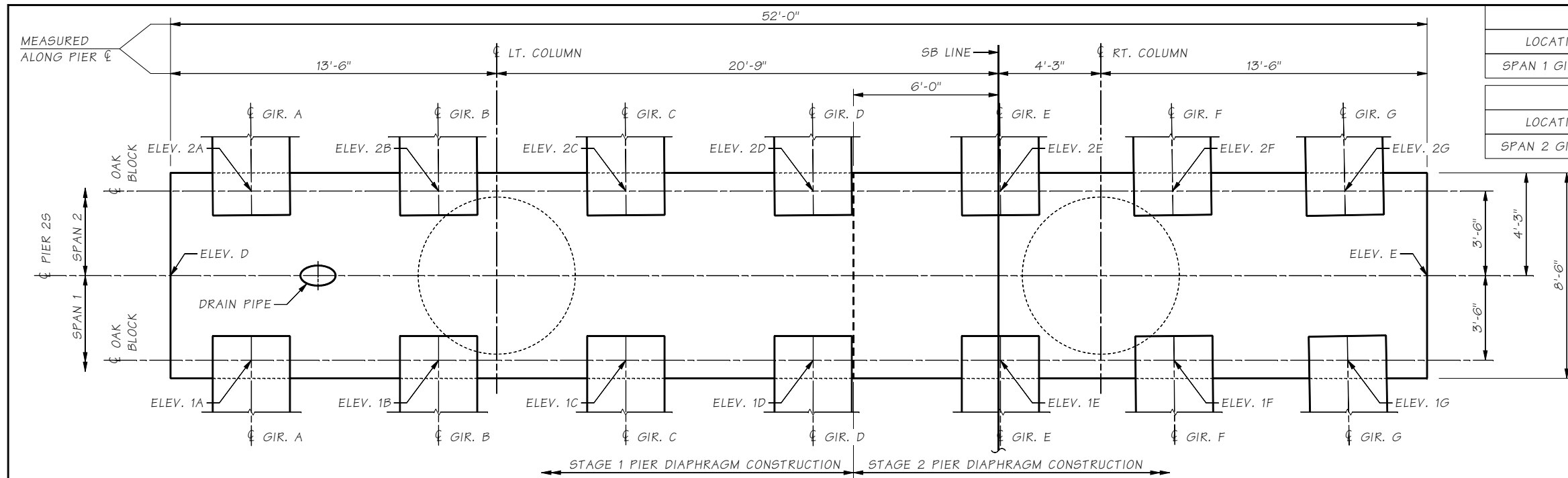

LOCATION	1A	1B	1C	1D	1E	1F	1G
SPAN 1 GIRDERS	40.23	40.36	40.50	40.63	40.77	40.89	41.02

LOCATION	2A	2B	2C	2D	2E	2F	2G
SPAN 2 GIRDERS	40.39	40.54	40.68	40.83	40.97	41.11	41.24

LOCATION	ELEVATION
D	39.92
E	40.82
F	47.35
G	48.28

NOTE:
SEE FRAMING PLAN FOR GIRDER SPACING.

PLAN

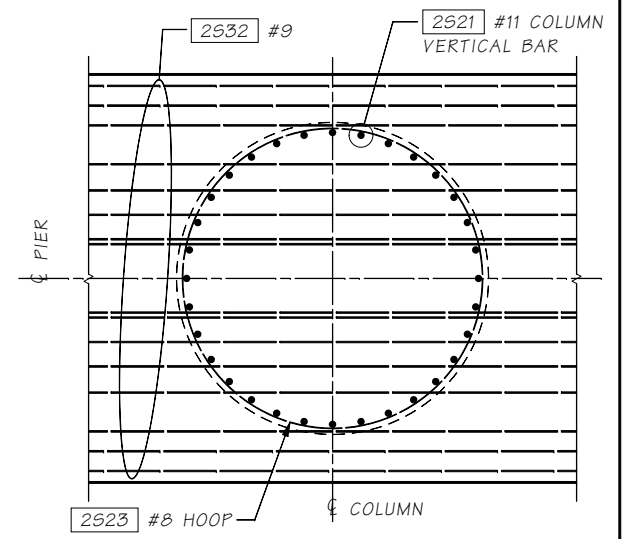
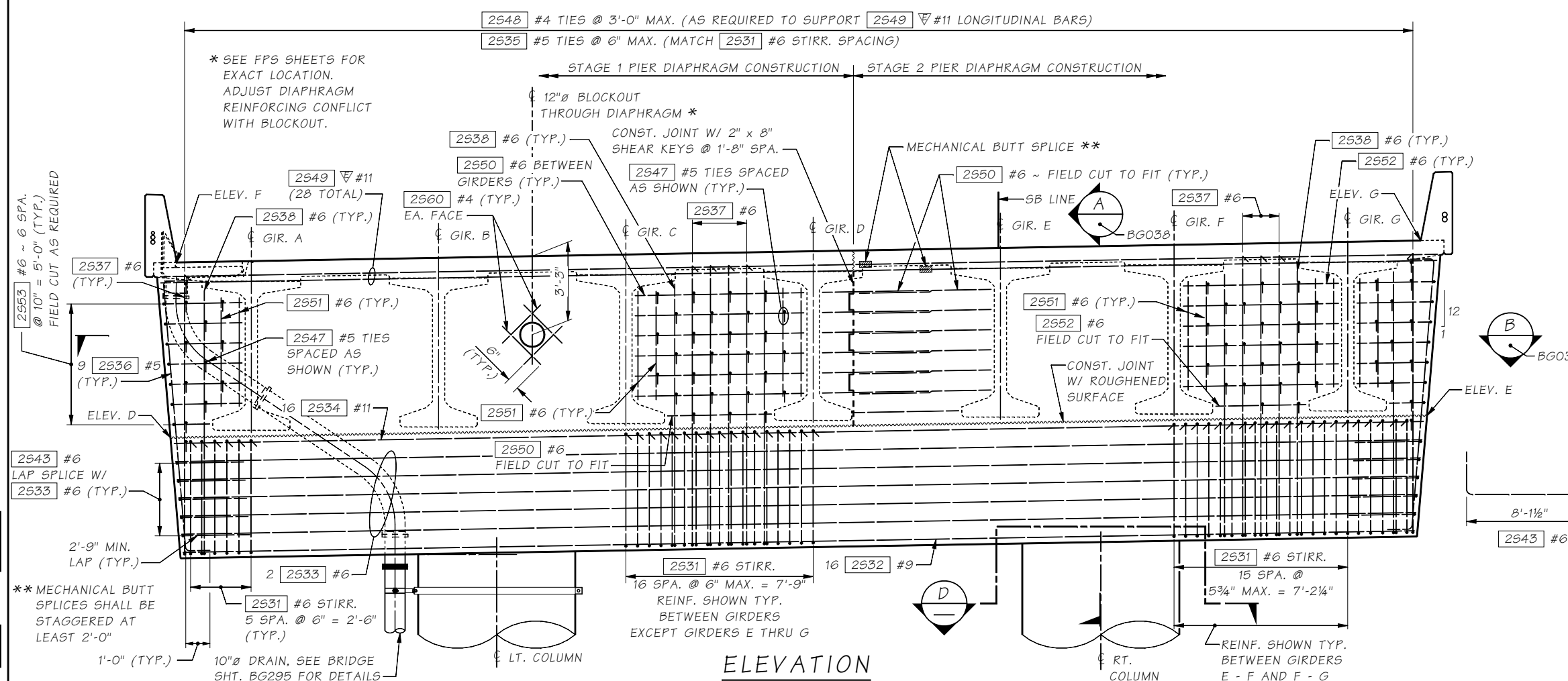

SECTION D

TRANSVERSE REINFORCING NOT SHOWN FOR CLARITY. ADJUST LONGITUDINAL BAR, TRANSVERSE STIRRUP, AND THE TIE SPACING AS REQUIRED TO CLEAR COLUMN VERTICAL BARS.

- NOTES:
1. SLAB REINFORCING NOT SHOWN FOR CLARITY.
 2. ADJUST STIRRUP AND TIE SPACING AS REQUIRED TO CLEAR COLUMN VERTICAL BARS.
 3. DIAPHRAGM REINFORCING SHOWN FOR SPAN 1 FACE ONLY. SEE SECTION B FOR DETAILS.

ELEVATION

SR 99 FILE NO. SHEET BG036

Bridge Design Engr.	Khaleghi, B	M:\Y-Team\AWV SOUTH INTERCHANGE\Window files\Pier 2s X-Beam Plan-Elev.WND			
Supervisor	Moore, TM	REGION NO.	STATE	FED. AID PROJ. NO.	SHEET NO.
Designed By	Lee, CS	10	WASH.		
Checked By	Glassford, P	JOB NUMBER	09A803		
Detailed By	Hanson, CE	DATE	REVISION	BY	APPD
Bridge Projects Engr.					
Prelim. Plan By					
Architect/Specialist					



BRIDGE AND STRUCTURES OFFICE

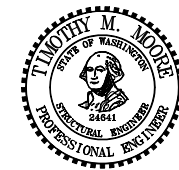

SR 99
ALASKAN WAY VIADUCT - REPLACEMENT
S HOLGATE ST TO S KING ST - PHASE 2
BRIDGE NO. 99/540 NB & SB
PIER 25 CROSSBEAM
PLAN AND ELEVATION

BRIDGE SHEET NO. BG036
SHEET 882 OF 1475 SHEETS

—DRAIN PIPE SEE BRIDGE
SHT. BG295 FOR DETAILS

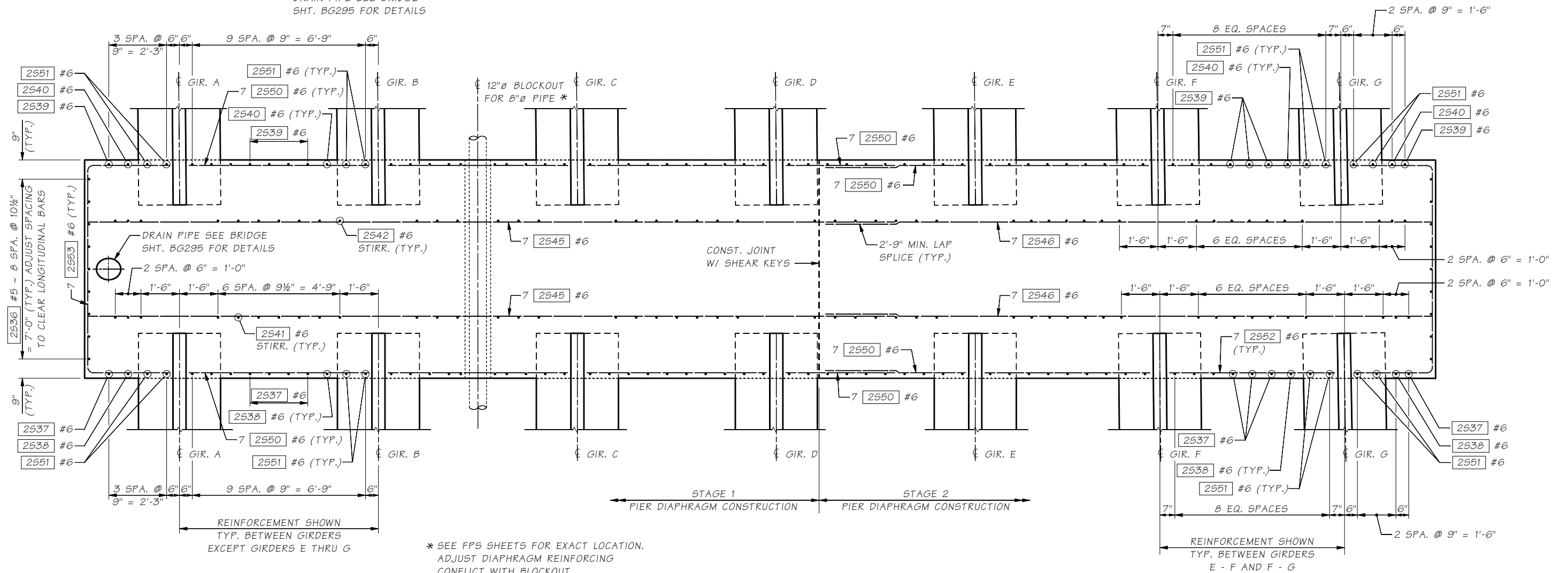

SECTION (B)

BG036

SR 99 FILE NO. SHEET BG037

Bridge Design Engr.	Khaleghi, B	M:\Y-Team\AWV SOUTH INTERCHANGE\window files\Pier 2s X-Beam Dtls.WND			
Supervisor	Moore, TM	REGION NO.	STATE	FED. AID PROJ. NO.	SHEET NO.
Designed By	Lee, CS	10	WASH.		TOTAL SHEETS
Checked By	Glassford, P	JOB NUMBER 09A803			
Detailed By	Hanson, CE				
Bridge Projects Engr.					
Prelim. Plan By					
Architect/Specialist		DATE	REVISION	BY	APPD



BRIDGE AND STRUCTURES OFFICE



SR 99
ALASKAN WAY VIADUCT - REPLACEMENT
S HOLGATE ST TO S KING ST - PHASE 2
BRIDGE NO. 99/540 NB & SB
PIER 25 CROSSBEAM DETAILS 1 OF 2

BRIDGE SHEET NO. BG037
SHEET 883 OF 1475 SHEETS

SR 99 FILE NO. SHEET BG038

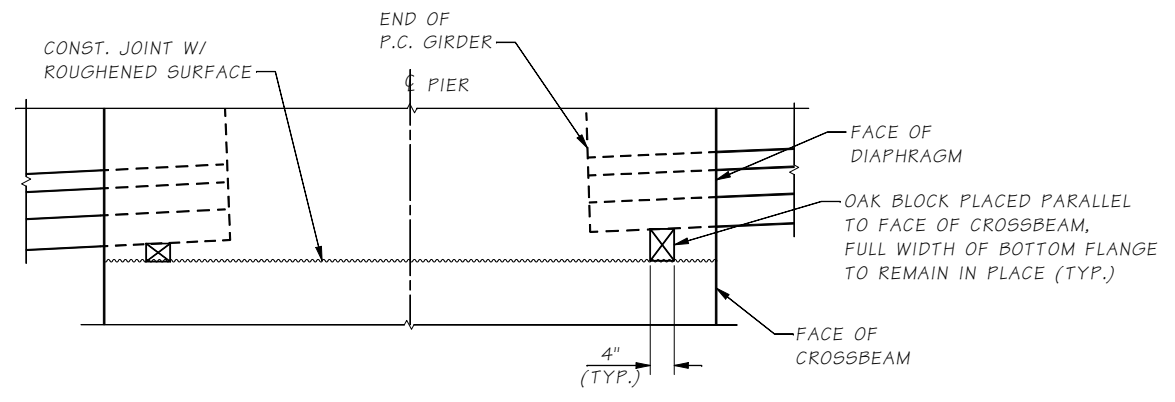

OAK BLOCK DETAIL

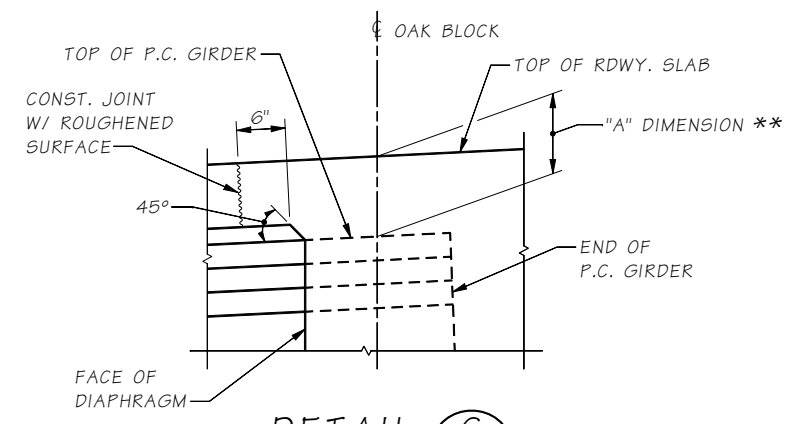

DETAIL C
REINFORCING NOT SHOWN FOR CLARITY

** SEE "GIRDER SCHEDULE" SHEETS

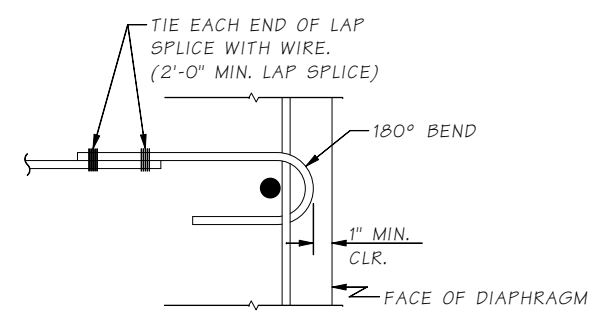

TIE BAR DETAIL

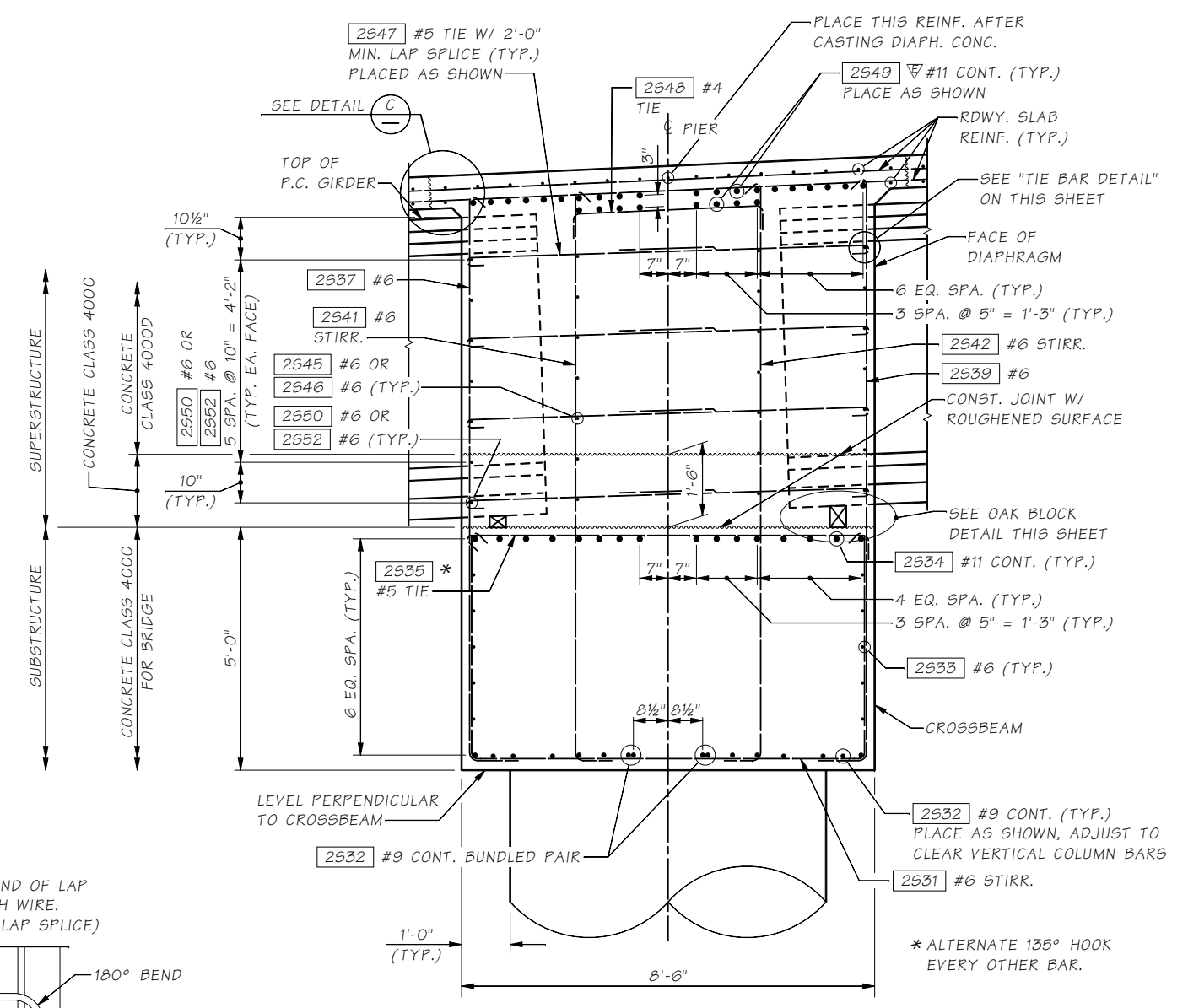

SECTION A
BG036

- NOTES:
- LONGITUDINAL DIMENSIONS ARE NORMAL TO SKEW.
 - FOR CONCRETE PLACEMENT PROCEDURE, SEE "CONSTRUCTION SEQUENCE" SHEET.

Bridge Design Engr.	Khaleghi, B	M:\Y-Team\AWV SOUTH INTERCHANGE\window files\Pier 2s X-Beam Dtls 2.WND				REGION NO.	STATE	FED. AID PROJ. NO.	SHEET NO.	TOTAL SHEETS
Supervisor	Moore, TM					10	WASH.			
Designed By	Lee, CS	05/09								
Checked By	Glassford, P	09/09								
Detailed By	Hanson, CE	05/09								
Bridge Projects Engr.										
Prelim. Plan By										
Architect/Specialist										
		DATE	REVISION	BY	APPD					



BRIDGE AND STRUCTURES OFFICE

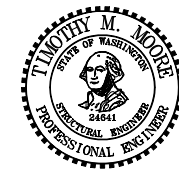

SR 99
ALASKAN WAY VIADUCT - REPLACEMENT
S HOLGATE ST TO S KING ST - PHASE 2
BRIDGE NO. 99/540 NB & SB
PIER 25 CROSSBEAM DETAILS 2 OF 2

BRIDGE SHEET NO. **BG038**
SHEET **884** OF **1475** SHEETS

SR 99 FILE NO. SHEET BG039

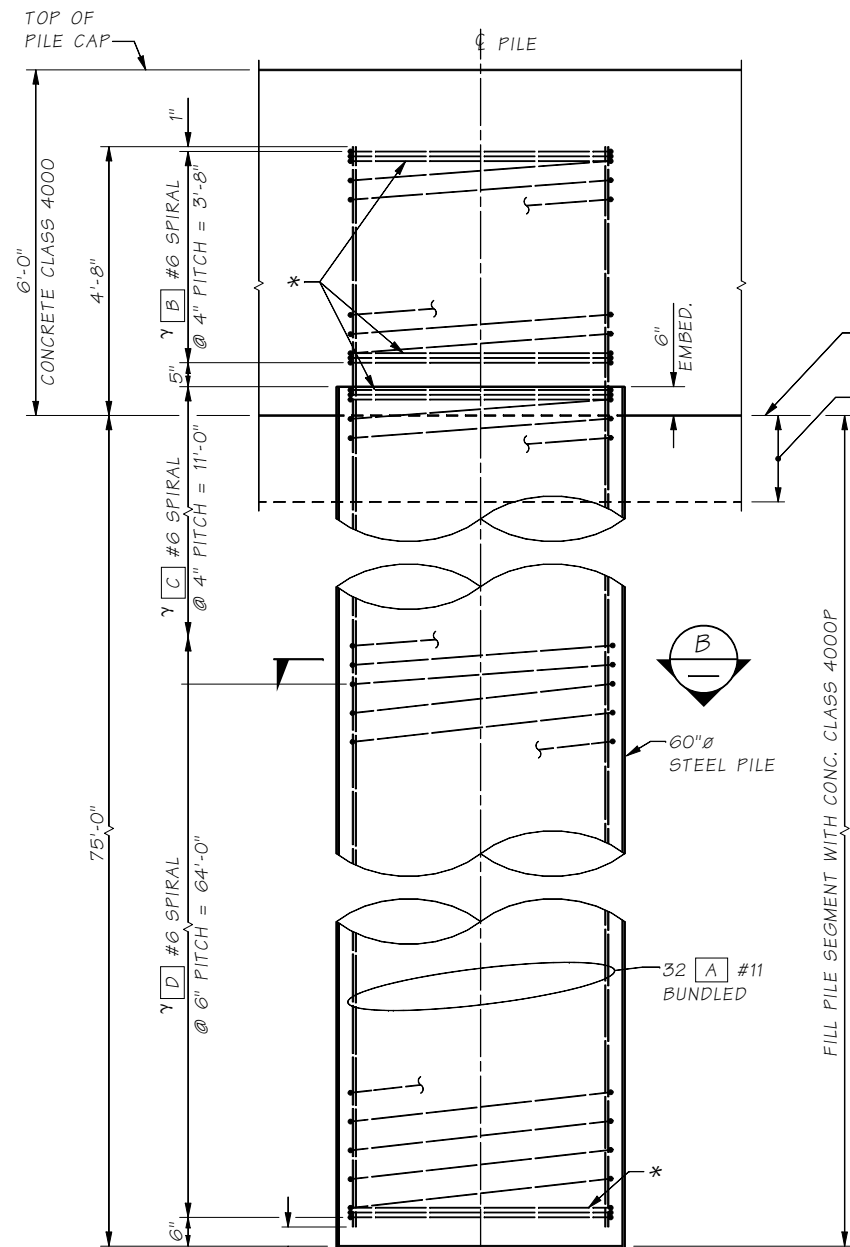

TYPICAL PILE ELEVATION

FIELD SPLICE LOCATION (PER CONTRACTOR) FOR FIT UP SEE DETAIL (W)

MIN. TIP ELEVATION SEE SPECIAL PROVISIONS

OPEN END WITH CUTTING SHOE, SEE "PILE TIP DETAIL" ON THIS SHEET

* SEE SPIRAL TERMINATION DETAIL ON THIS SHEET.

WELDED SPLICE ONLY (SEE WELDED LAP SPLICE DETAIL ON THIS SHEET)

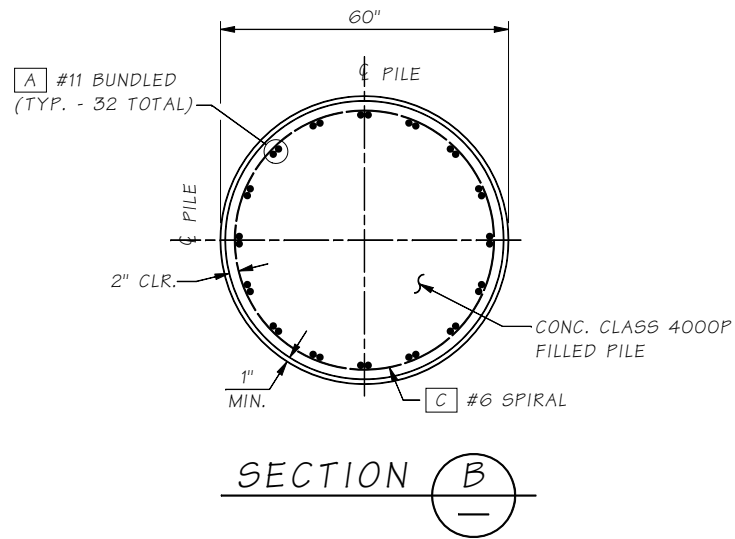

SECTION B

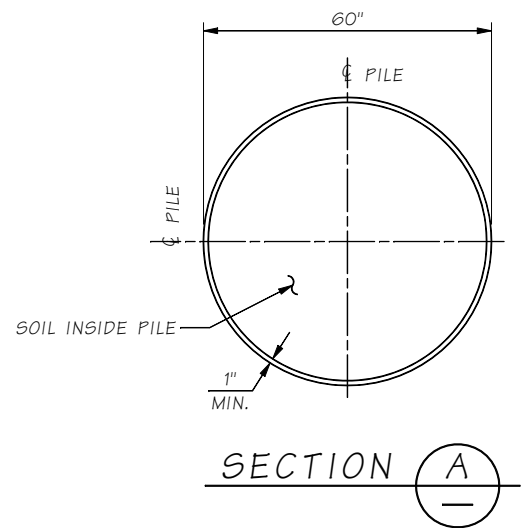

SECTION A

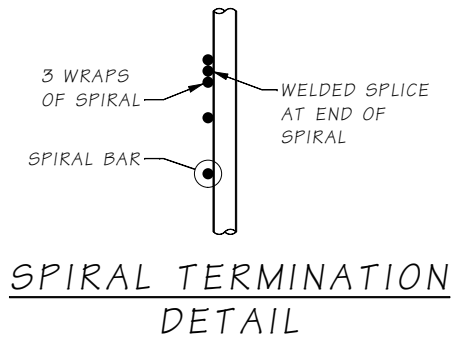

SPIRAL TERMINATION DETAIL

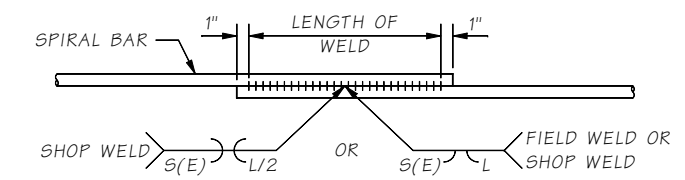

WELDED LAP SPLICE DETAIL

WELDING SHALL MEET THE REQUIREMENTS OF STD. SPEC. 6-02.3(24)E FOR WELD DIMENSIONS, SEE TABLE BELOW.

DEFORMED BAR	WELD DIMENSIONS		
	S	E	LENGTH (L)
#6	3/8	3/16	6"

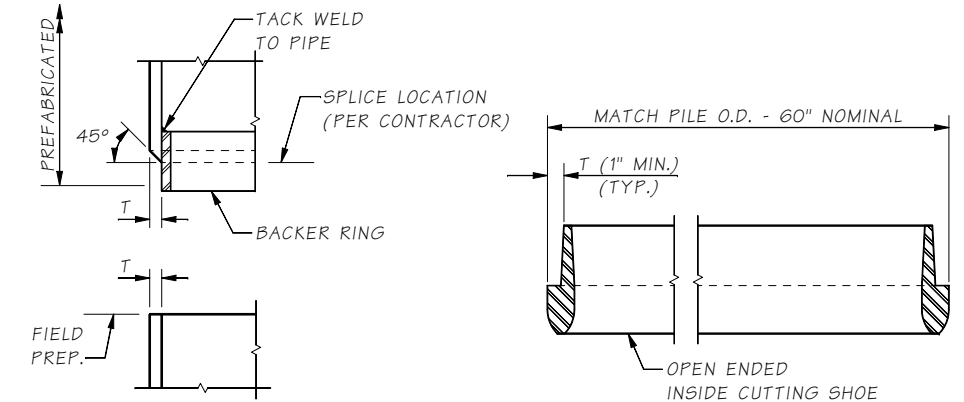

DETAIL W

PERMISSIBLE WELD SPLICE DETAILS FOR STEEL PIPE PILES. SEE "100% U.T. INSPECTION LIMITS" ON BR. SHT. BG067 FOR WELDING INSPECTION REQUIREMENTS.

PILE TIP DETAIL

STEEL PILE WALL THICKNESS (T) AND CUTTING SHOE THICKNESS SHALL BE DETERMINED BY CONTRACTOR. SEE STD. SPEC. 6-05.3(B)

PILE BAR LIST

ALL REINFORCING SHALL BE ASTM A 706

PIER	PILES REQUIRED PER PIER	MARK	BAR SIZE	BARS PER PILE	LENGTH	BEND TYPE	WT. (LBS.) PER PILE
35	8	A	#11	32	79'-4"	STRAIGHT	13,489
		B	#6	1	(a)	SPIRAL	324
		C	#6	1	(a)	SPIRAL	755
		D	#6	1	(a)	SPIRAL	2,806
TOTAL							17,374

(a) ~ DETERMINED FROM PLANS

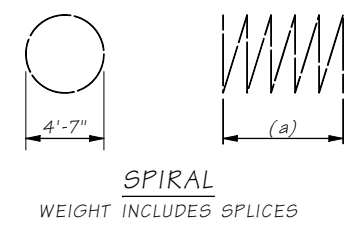

Bridge Design Engr.	Khaleghi, B	M:\Y-Team\AWV SOUTH INTERCHANGE\window files\Pier 3s Pile Dtls.WND			
Supervisor	Moore, TM	REGION NO.	STATE	FED. AID PROJ. NO.	SHEET NO. TOTAL SHEETS
Designed By	Schultz, E 09/09	10	WASH.		
Checked By	Lee, CS 09/09	JOB NUMBER 09A803			
Detailed By	Hanson, CE 09/09				
Bridge Projects Engr.					
Prelim. Plan By					
Architect/Specialist		DATE	REVISION	BY	APPD



BRIDGE AND STRUCTURES OFFICE

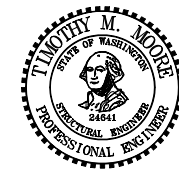

SR 99
ALASKAN WAY VIADUCT - REPLACEMENT
S HOLGATE ST TO S KING ST - PHASE 2
BRIDGE NO. 99/540 NB & SB
PIER 35 PILE DETAILS

BRIDGE SHEET NO. BG039
SHEET 885 OF 1475 SHEETS

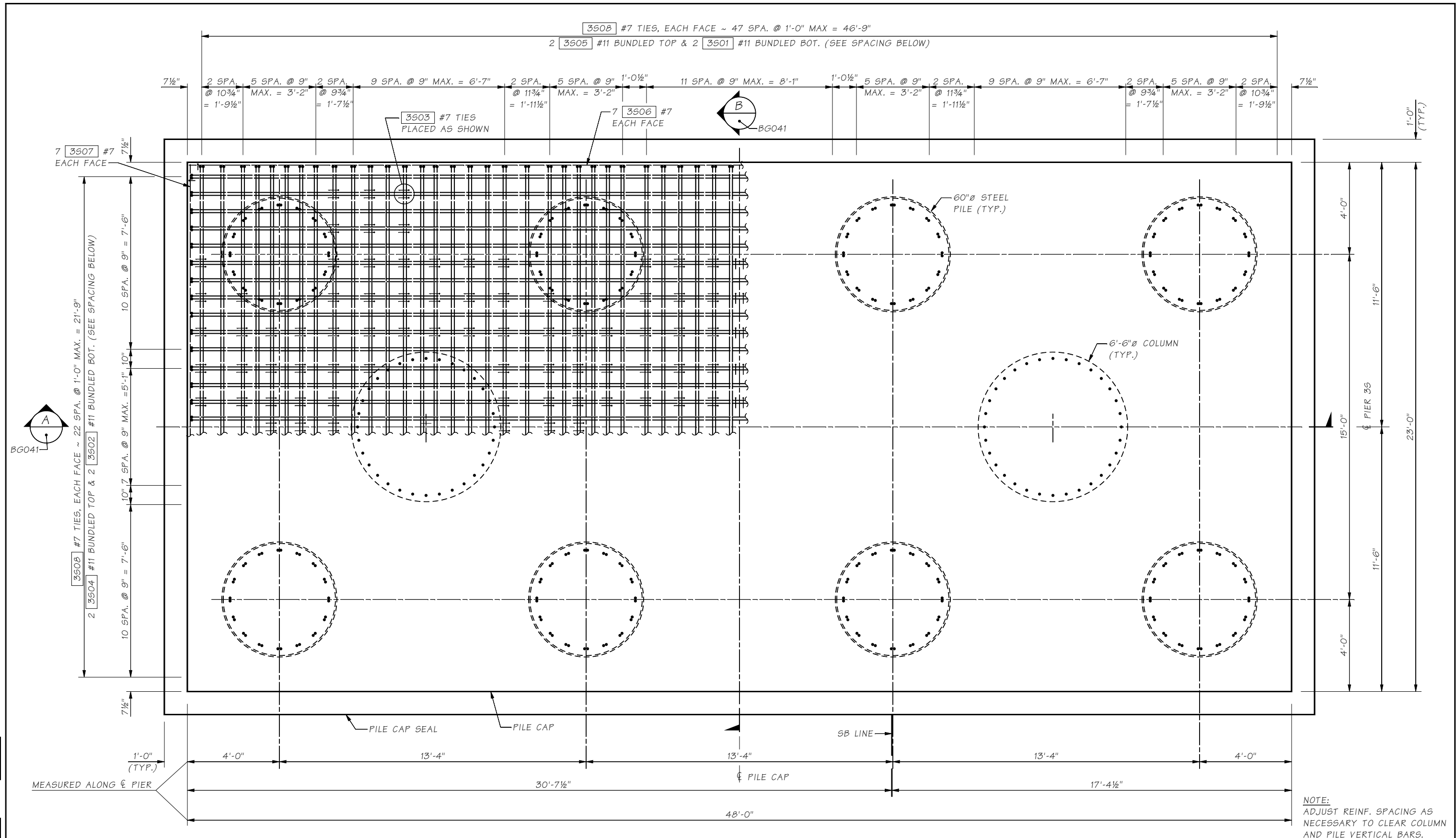

PLAN

NOTE:
ADJUST REINF. SPACING AS
NECESSARY TO CLEAR COLUMN
AND PILE VERTICAL BARS.

SR 99 FILE NO. SHEET BGO40

Bridge Design Engr.	Khaleghi, B	M:\Y-Team\AWV SOUTH INTERCHANGE\window files\Pier 3s Pile Cap Plan.WND			
Supervisor	Moore, TM	REGION NO.	STATE	FED. AID PROJ. NO.	SHEET NO.
Designed By	Schultz, E	10	WASH.		TOTAL SHEETS
Checked By	Lee, CS	JOB NUMBER			
Detailed By	Hanson, CE	09A803			
Bridge Projects Engr.		DATE	REVISION	BY	APPD
Prelim. Plan By					
Architect/Specialist					



BRIDGE
AND
STRUCTURES
OFFICE

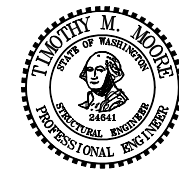

SR 99
ALASKAN WAY VIADUCT - REPLACEMENT
S HOLGATE ST TO S KING ST - PHASE 2
BRIDGE NO. 99/540 NB & SB

PIER 3S PILE CAP PLAN

BRIDGE SHEET NO.
BGO40
SHEET
886
OF
1475
SHEETS

SR 99 FILE NO. SHEET BG041

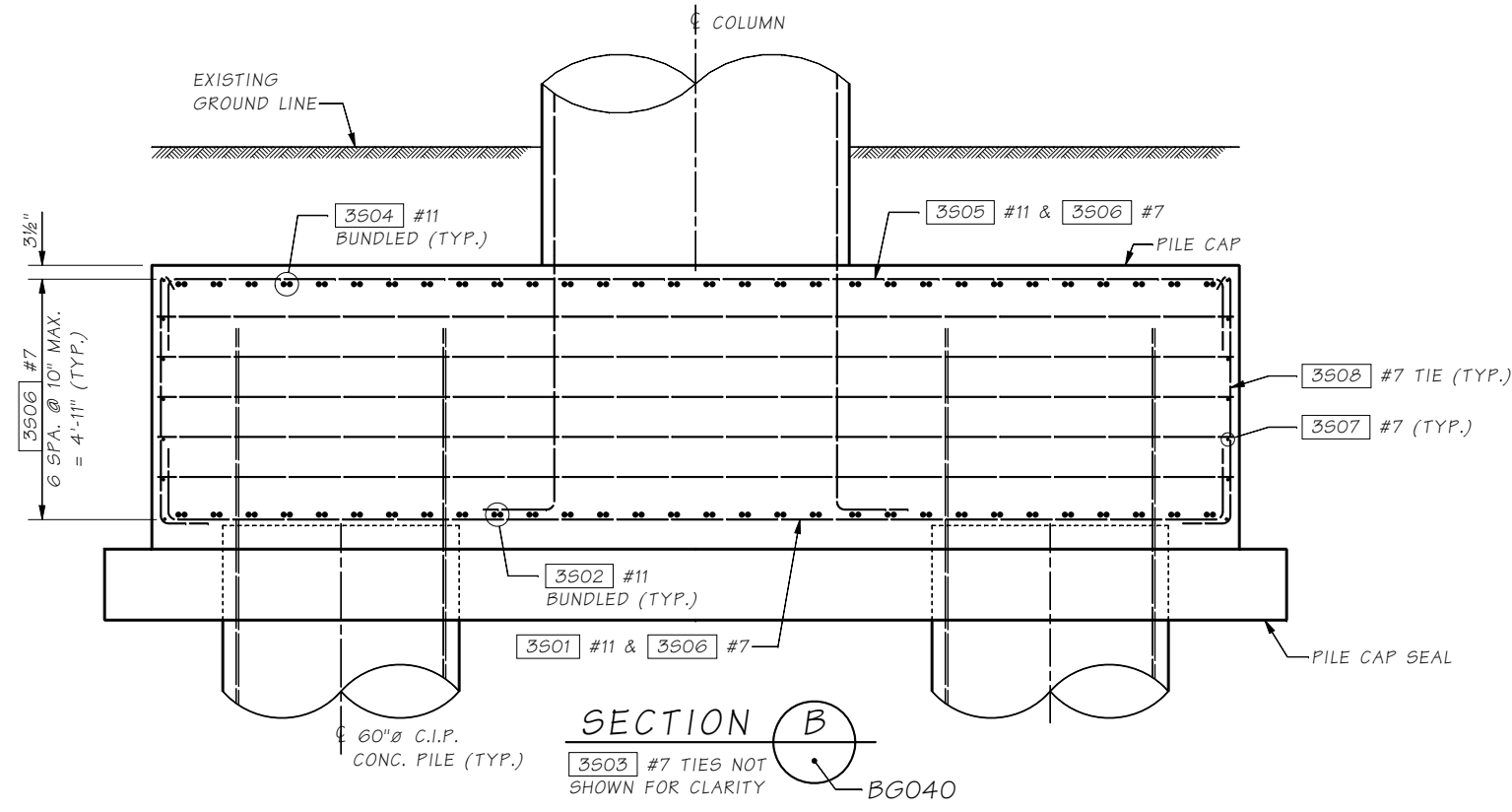

SECTION B
 3503 #7 TIES NOT SHOWN FOR CLARITY
 BG040

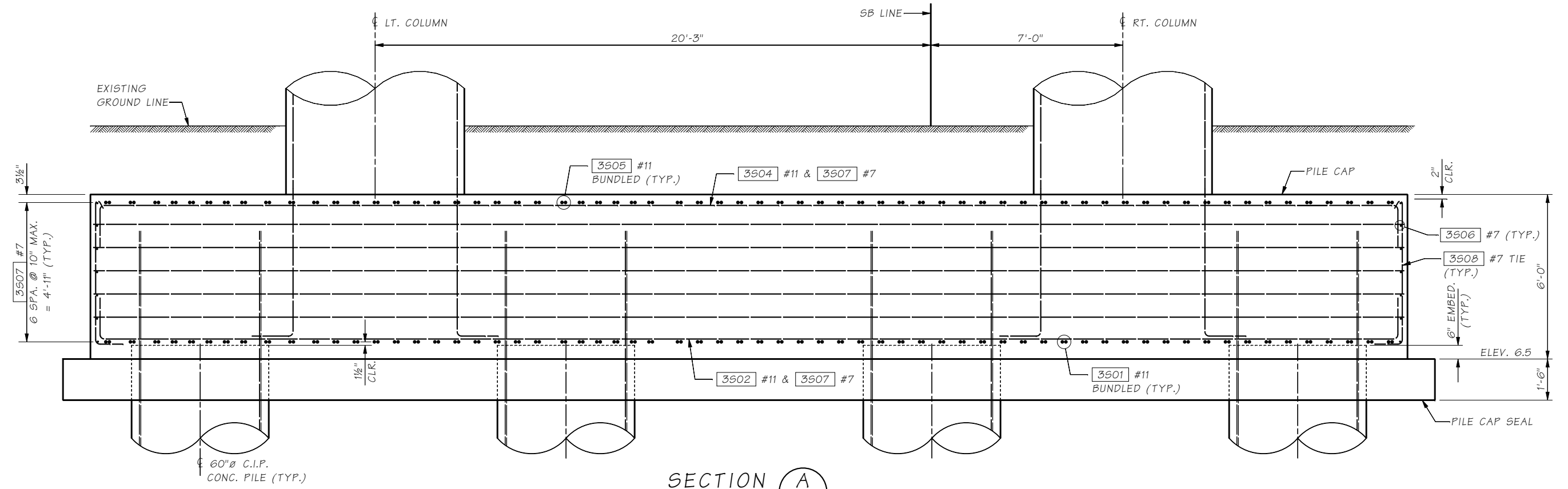

SECTION A
 3503 #7 TIES NOT SHOWN FOR CLARITY
 BG040

Bridge Design Engr.	Khaleghi, B	M:\Y-Team\AWV SOUTH INTERCHANGE\window files\Pier 3s Pile Cap Elev.WND			
Supervisor	Moore, TM	REGION NO.	STATE	FED. AID PROJ. NO.	SHEET NO.
Designed By	Schultz, E 09/09	10	WASH.		TOTAL SHEETS
Checked By	Lee, CS 09/09	JOB NUMBER 09A803			
Detailed By	Hanson, CE 09/09				
Bridge Projects Engr.		DATE	REVISION	BY	APPD
Prelim. Plan By					
Architect/Specialist					



BRIDGE AND STRUCTURES OFFICE

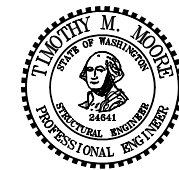

SR 99
ALASKAN WAY VIADUCT - REPLACEMENT
S HOLGATE ST TO S KING ST - PHASE 2
 BRIDGE NO. 99/540 NB & SB
PIER 3S PILE CAP ELEVATION

BRIDGE SHEET NO. **BG041**
 SHEET **887** OF **1475** SHEETS

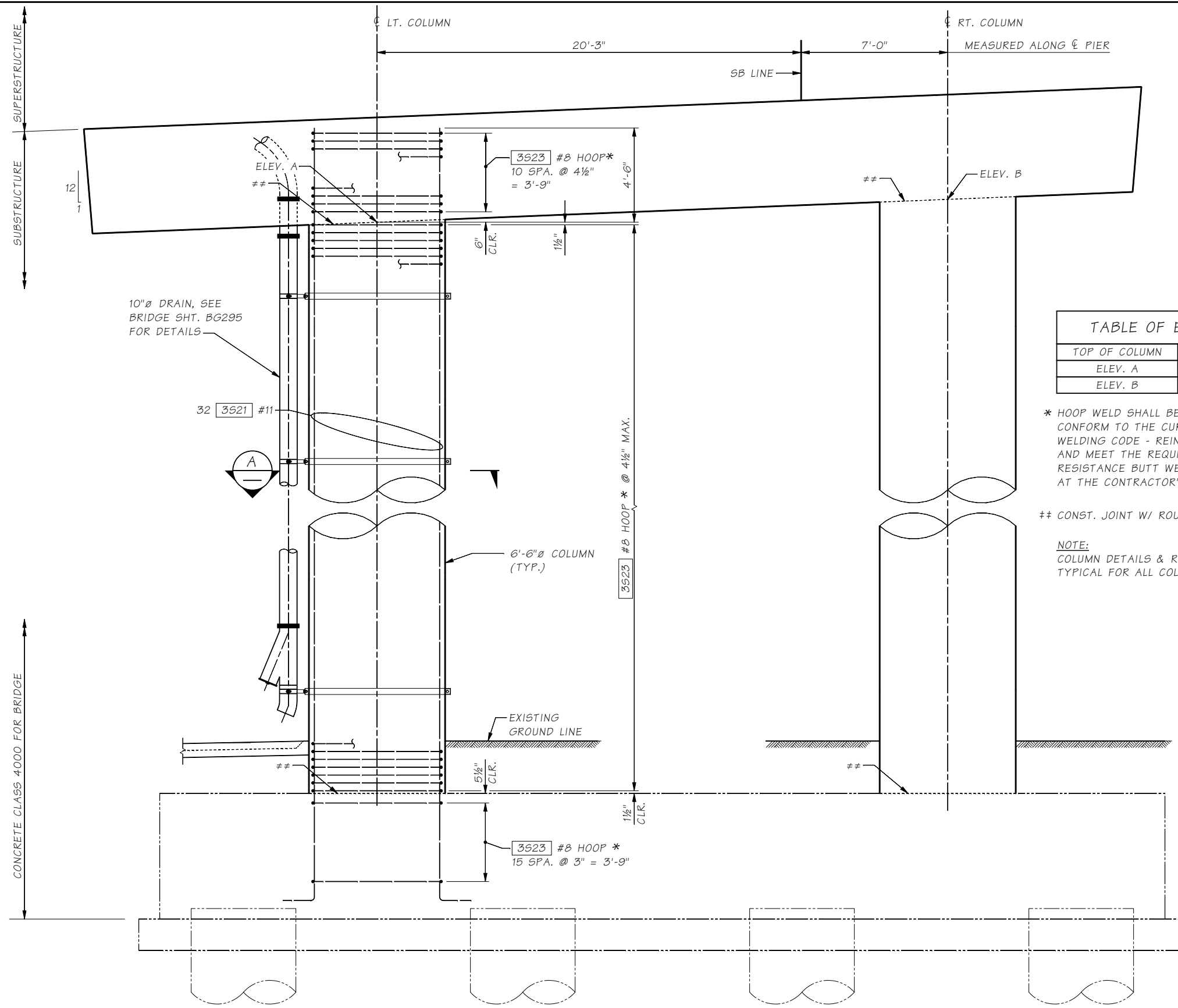

COLUMN ELEVATION - PIER 35

TABLE OF ELEVATIONS	
TOP OF COLUMN	ELEVATION
ELEV. A	40.28
ELEV. B	41.37

* HOOP WELD SHALL BE DIRECT BUTT-WELDED AND CONFORM TO THE CURRENT EDITION OF STRUCTURAL WELDING CODE - REINFORCING STEEL OF AWS(D1.4) AND MEET THE REQUIREMENTS OF STD. SPEC. 6-02.3(24)E. RESISTANCE BUTT WELDED SPLICE MAY BE SUBSTITUTED AT THE CONTRACTOR'S OPTION. SEE SPECIAL PROVISIONS.

CONST. JOINT W/ ROUGHENED SURFACE

NOTE:
COLUMN DETAILS & REINFORCING TYPICAL FOR ALL COLUMNS.

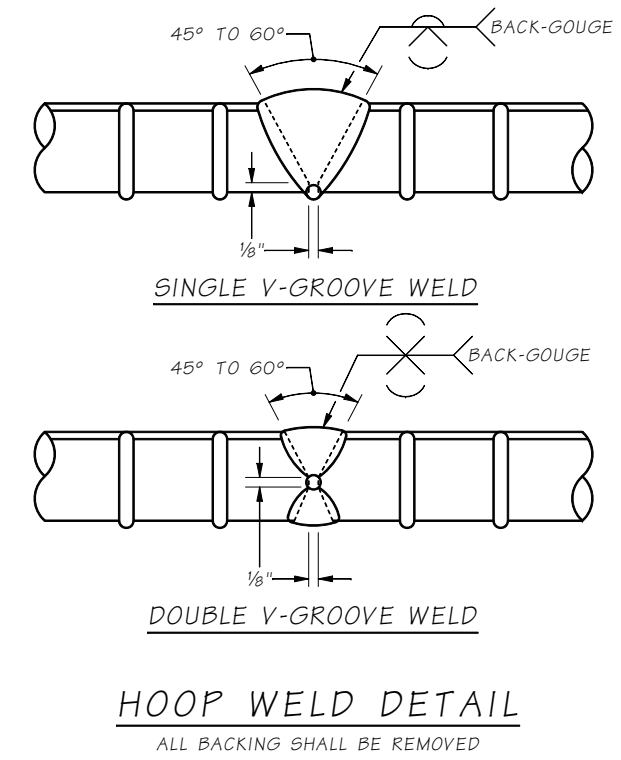
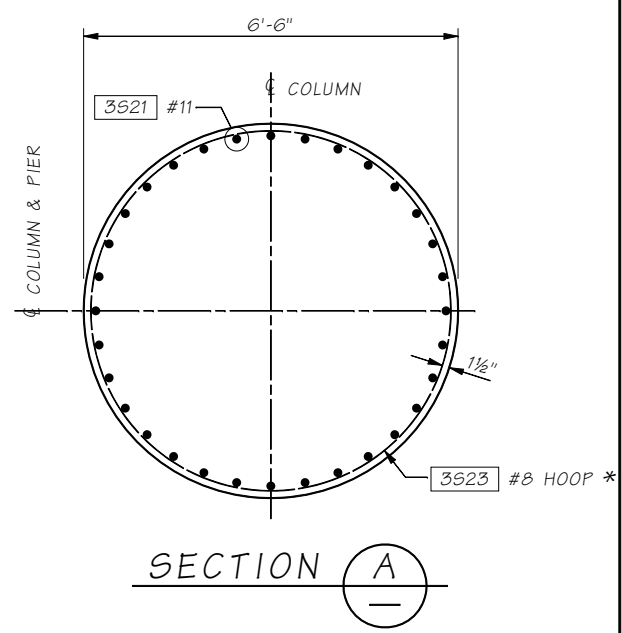

HOOP WELD DETAIL
ALL BACKING SHALL BE REMOVED

SR 99 FILE NO. SHEET BG042

Bridge Design Engr. Khaleghi, B	M:\Y-Team\AWV SOUTH INTERCHANGE\window files\Pier 3s Col Dtls.WND			
Supervisor Moore, TM	REGION NO.	STATE	FED. AID PROJ. NO.	SHEET TOTAL
Designed By Lee, CS 09/09	10	WASH.		
Checked By Schultz, E 09/09	JOB NUMBER 09A803			
Detailed By Hanson, CE 09/09				
Bridge Projects Engr.	DATE	REVISION	BY	APPD
Prelim. Plan By				
Architect/Specialist				



BRIDGE AND STRUCTURES OFFICE

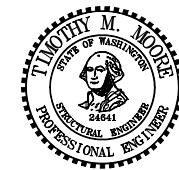

SR 99
ALASKAN WAY VIADUCT - REPLACEMENT
S HOLGATE ST TO S KING ST - PHASE 2
BRIDGE NO. 99/540 NB & SB
PIER 35 COLUMN DETAILS

BRIDGE SHEET NO. BG042
SHEET 888 OF 1475 SHEETS

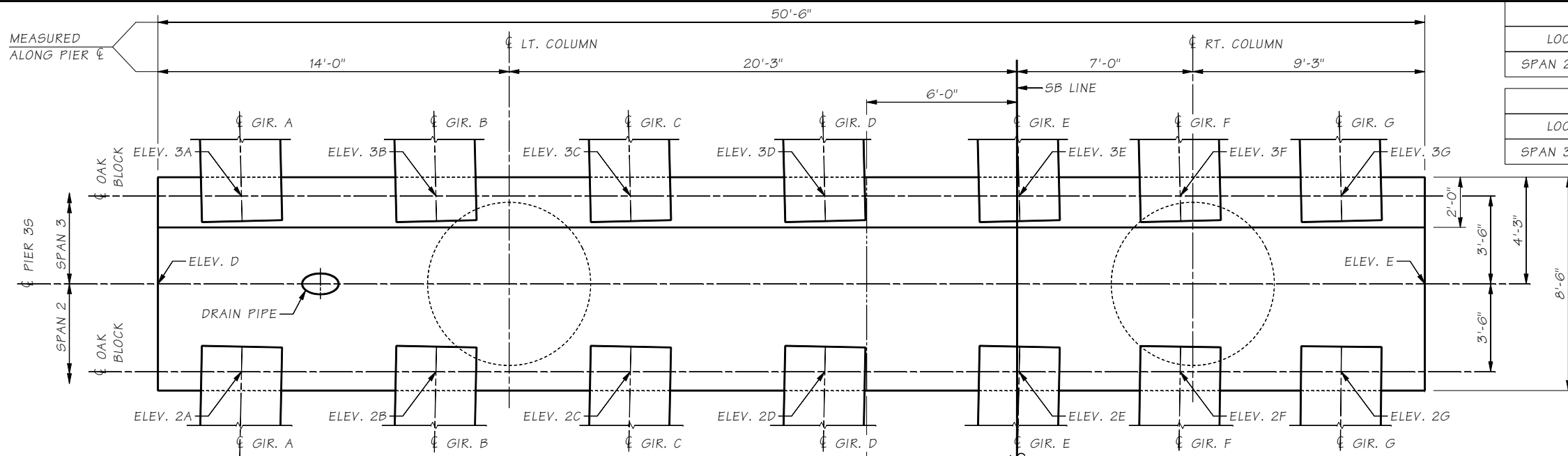

LOCATION	2A	2B	2C	2D	2E	2F	2G
SPAN 2 GIRDERS	45.14	45.45	45.76	46.07	46.39	46.64	46.90

LOCATION	3A	3B	3C	3D	3E	3F	3G
SPAN 3 GIRDERS	45.49	45.80	46.11	46.42	46.73	46.98	47.24

LOCATION	ELEVATION
D	44.72
E	46.74
F	52.29
G	54.29

NOTE:
SEE FRAMING PLAN FOR GIRDER SPACING.

- * CAP PIPE DURING BRIDGE PHASE 1 OPERATION.
- ** AFTER BRIDGE STAGE 1 OPERATIONAL PHASE, REMOVE & REPLACE NOZZLE TO EAST SIDE AND CAP FPS SYSTEM AT FACE OF X-BM.
- *** FUTURE CAP AFTER BRIDGE STAGE 1.

PLAN

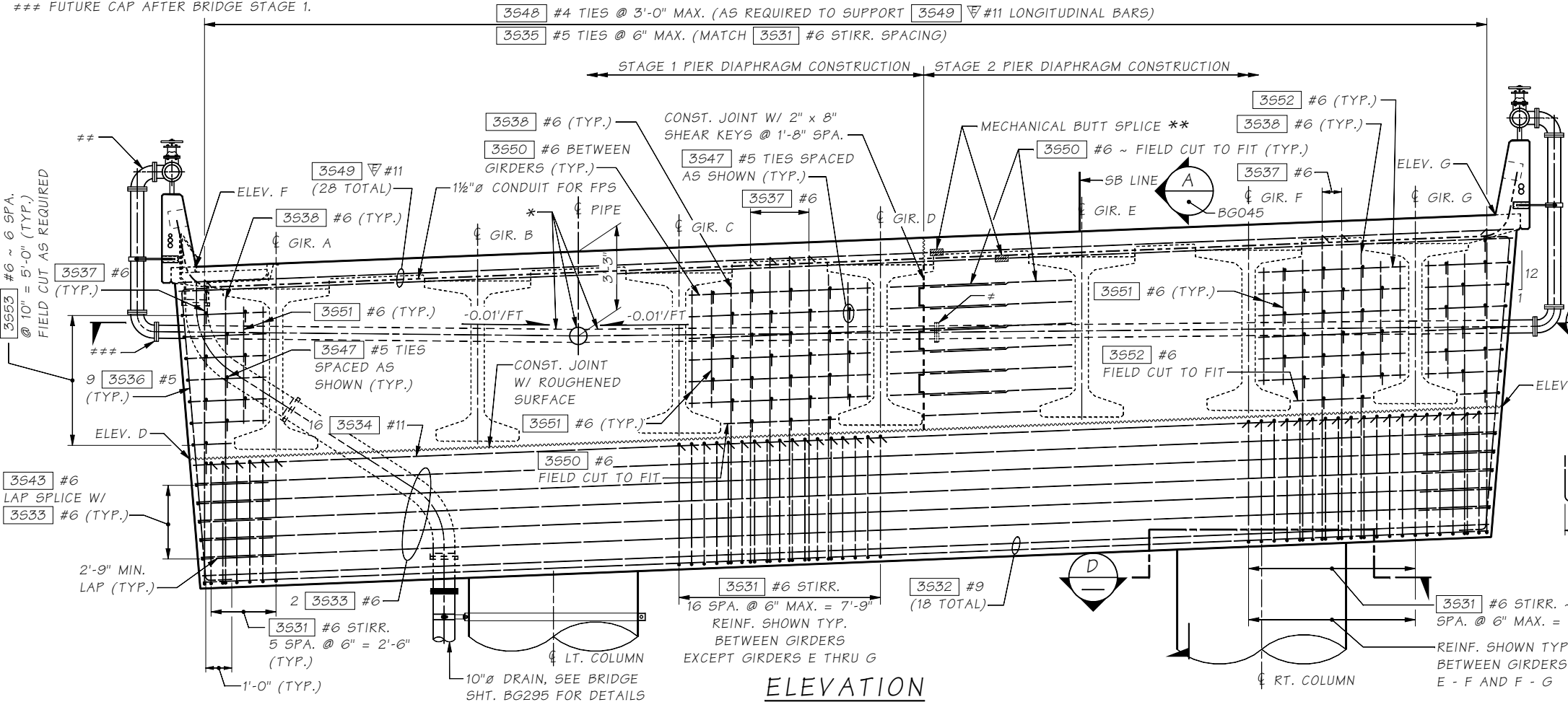

* FPS PIPE EMBEDDED IN DIAPHRAGM. SEE FPS SHEETS FOR EXACT LOCATION. ADJUST DIAPHRAGM REINFORCING CONFLICT WITH PIPES.

** MECHANICAL BUTT SPLICES SHALL BE STAGGERED AT LEAST 2'-0"

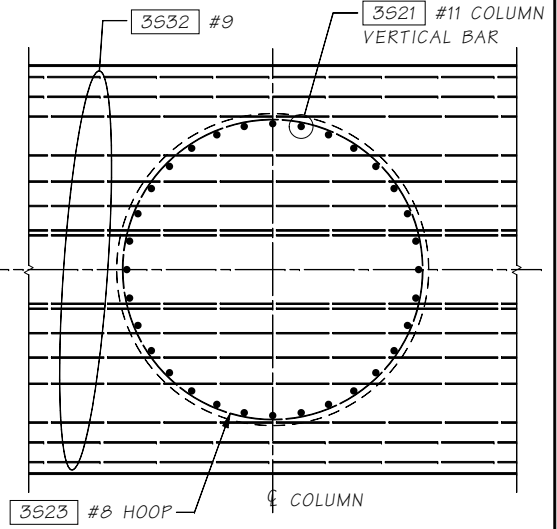

SECTION D

TRANSVERSE REINFORCING NOT SHOWN FOR CLARITY. ADJUST LONGITUDINAL BAR, TRANSVERSE STIRRUP, AND THE TIE SPACING AS REQUIRED TO CLEAR COLUMN VERTICAL BARS.

- NOTES:
1. SLAB REINFORCING NOT SHOWN FOR CLARITY.
 2. ADJUST STIRRUP AND TIE SPACING AS REQUIRED TO CLEAR COLUMN VERTICAL BARS.
 3. DIAPHRAGM REINFORCING SHOWN FOR SPAN 2 FACE ONLY. SEE SECTION B FOR DETAILS.

ELEVATION

SR 99 FILE NO. SHEET BG043

Bridge Design Engr. Khaleghi, B	M:\Y-Team\AWV SOUTH INTERCHANGE\Window files\Pier 3s X-Beam Plan-Elev.WND			
Supervisor Moore, TM	REGION NO. 10	STATE WASH.	FED. AID PROJ. NO.	SHEET NO. 889
Designed By Lee, CS 10/08	TOTAL SHEETS 1475			
Checked By Glassford, P 09/09	JOB NUMBER 09A803			
Detailed By Hanson, CE 10/08	DATE			
Bridge Projects Engr.	REVISION			
Prelim. Plan By	BY APPD			
Architect/Specialist	DATE			



BRIDGE AND STRUCTURES OFFICE

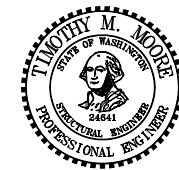

SR 99
ALASKAN WAY VIADUCT - REPLACEMENT
S HOLGATE ST TO S KING ST - PHASE 2
BRIDGE NO. 99/540 NB & SB

PIER 3S CROSSBEAM
PLAN AND ELEVATION

BRIDGE SHEET NO. BG043
SHEET 889 OF 1475 SHEETS

SR 99 FILE NO. SHEET BG044

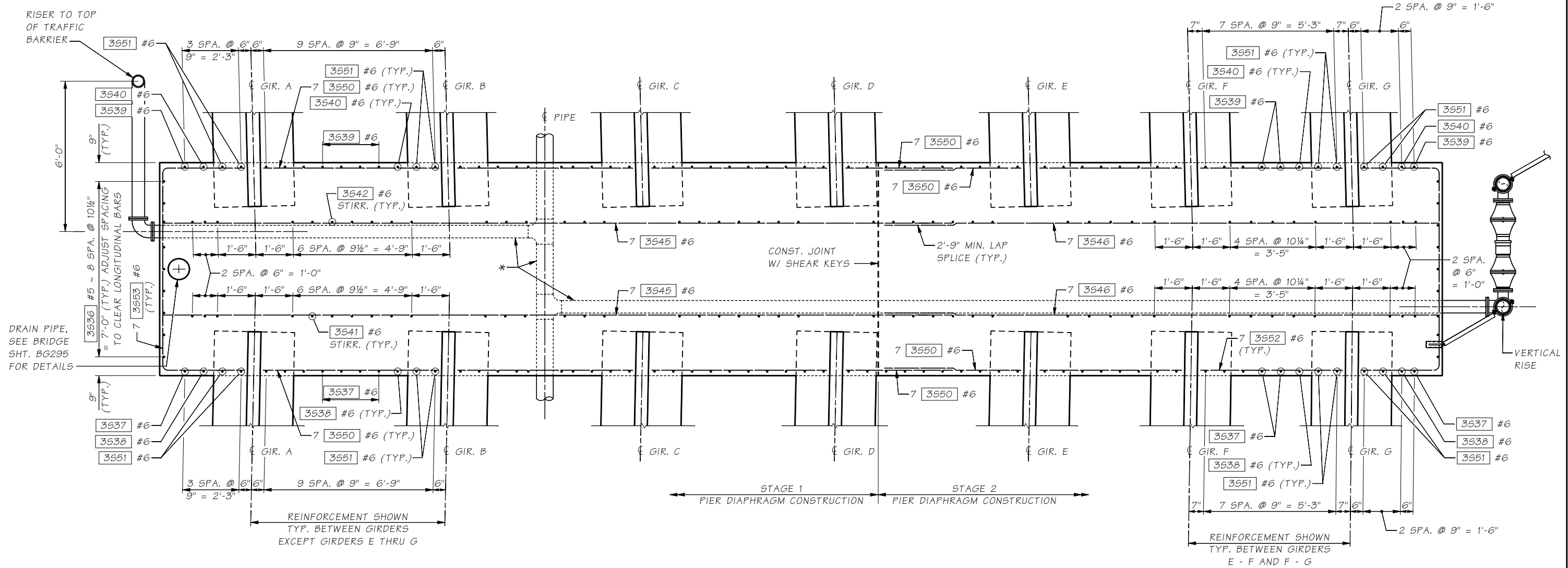

SECTION B
BG043

Bridge Design Engr.	Khaloghi, B	M:\Y-Team\AWV SOUTH INTERCHANGE\window files\Pier 3s X-Beam Dtls.WND			
Supervisor	Moore, TM	REGION NO.	STATE	FED. AID PROJ. NO.	SHEET NO.
Designed By	Lee, CS	10	WASH.		TOTAL SHEETS
Checked By	Glassford, P	JOB NUMBER			
Detailed By	Hanson, CE	09A803			
Bridge Projects Engr.		DATE	REVISION	BY	APPD
Prelim. Plan By					
Architect/Specialist					



BRIDGE
AND
STRUCTURES
OFFICE

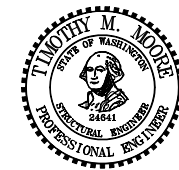

SR 99
ALASKAN WAY VIADUCT - REPLACEMENT
S HOLGATE ST TO S KING ST - PHASE 2
BRIDGE NO. 99/540 NB & SB
PIER 3S CROSSBEAM DETAILS 1 OF 2

BRIDGE SHEET NO. BG044
SHEET 890 OF 1475 SHEETS

** FPS PIPE EMBEDDED IN DIAPHRAGM,
SEE FPS SHEETS FOR EXACT LOCATION.
ADJUST DIAPHRAGM REINFORCING
CONFLICT WITH PIPES.

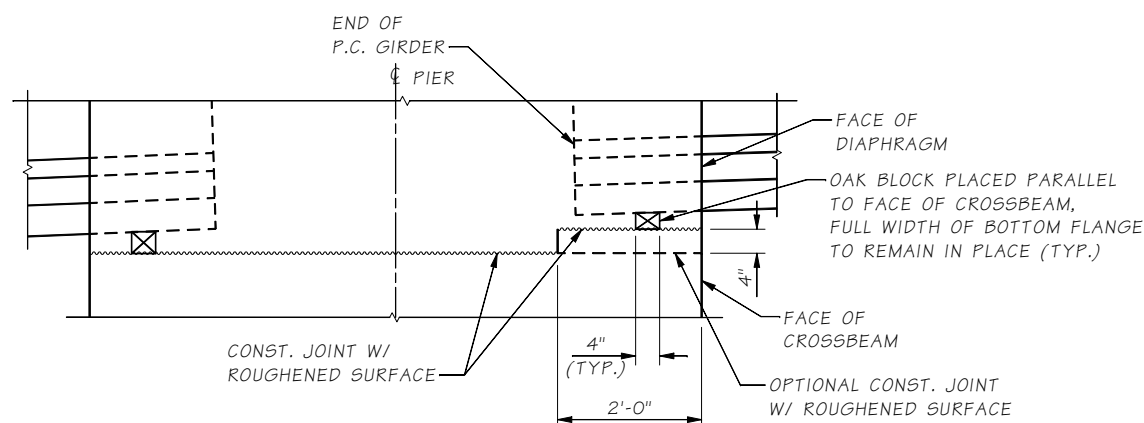

OAK BLOCK DETAIL

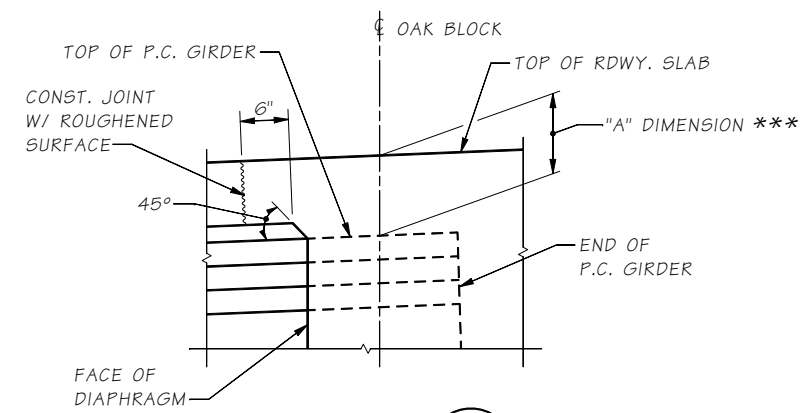

DETAIL C
REINFORCING NOT SHOWN FOR CLARITY

*** SEE "GIRDER SCHEDULE" SHEETS

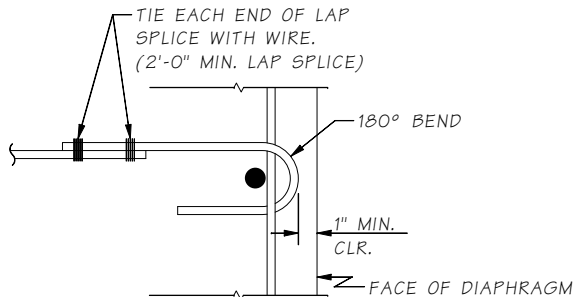

TIE BAR DETAIL

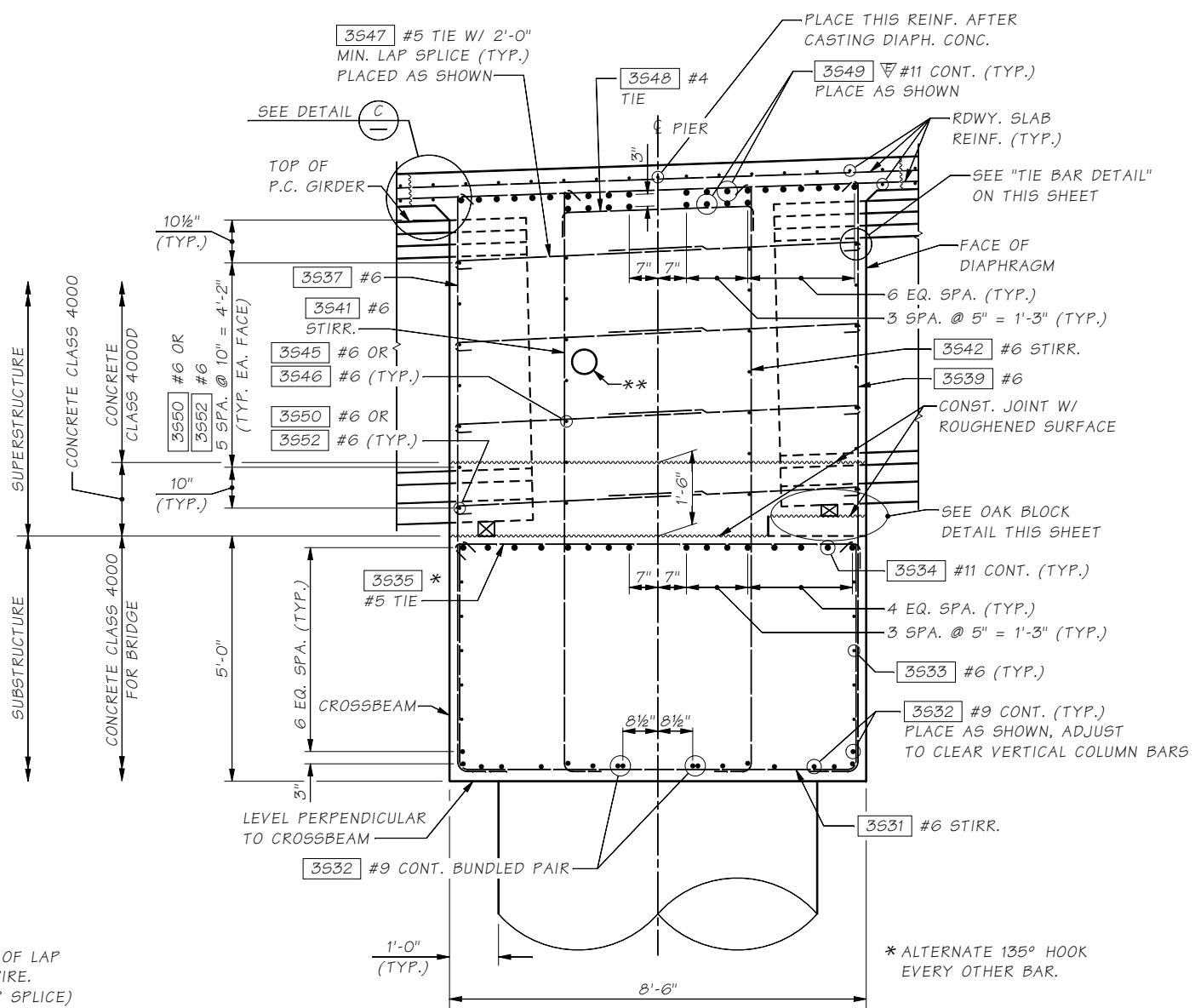

SECTION A

- NOTES:
- LONGITUDINAL DIMENSIONS ARE NORMAL TO SKEW.
 - FOR CONCRETE PLACEMENT PROCEDURE, SEE "CONSTRUCTION SEQUENCE" SHEET.

SR 99 FILE NO. SHEET BG045

Bridge Design Engr.	Khaleghi, B	M:\Y-Team\AWV SOUTH INTERCHANGE\window files\Pier 3s X-Beam Dtls 2.WND	REGION NO.	STATE	FED. AID PROJ. NO.	SHEET NO.	TOTAL SHEETS
Supervisor	Moore, TM		10	WASH.			
Designed By	Lee, CS	05/09					
Checked By	Glassford, P	09/09					
Detailed By	Hanson, CE	05/09					
Bridge Projects Engr.			JOB NUMBER				
Prelim. Plan By			09A803				
Architect/Specialist		DATE	REVISION	BY	APPD		



BRIDGE AND STRUCTURES OFFICE



SR 99
ALASKAN WAY VIADUCT - REPLACEMENT
S HOLGATE ST TO S KING ST - PHASE 2
BRIDGE NO. 99/540 NB & SB
PIER 3S CROSSBEAM DETAILS 2 OF 2

BRIDGE SHEET NO. BG045
SHEET 891 OF 1475 SHEETS

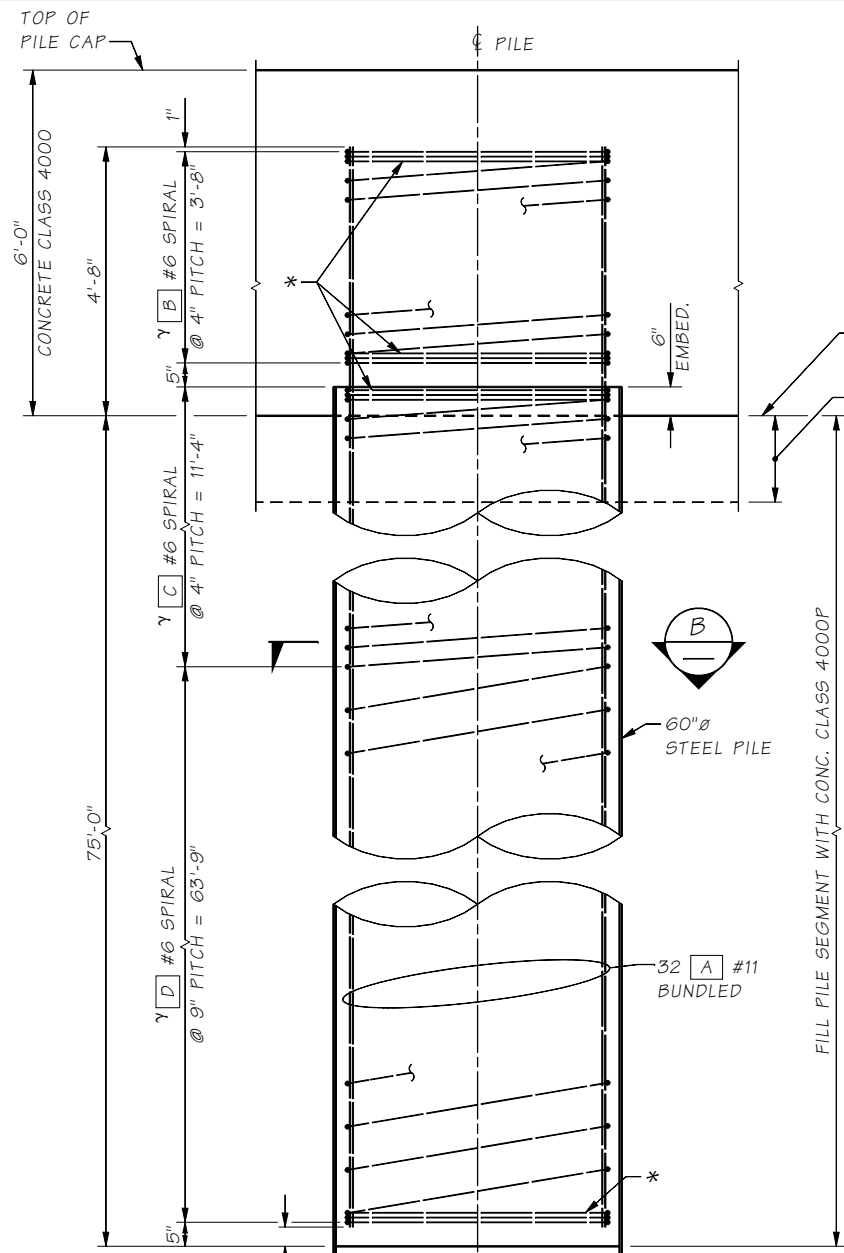

* SEE SPIRAL TERMINATION DETAIL ON THIS SHEET.

WELDED SPLICE ONLY (SEE WELDED LAP SPLICE DETAIL ON THIS SHEET)

FIELD SPLICE LOCATION (PER CONTRACTOR) FOR FIT UP SEE DETAIL

MIN. TIP ELEVATION SEE SPECIAL PROVISIONS

OPEN END WITH CUTTING SHOE, SEE "PILE TIP DETAIL" ON THIS SHEET

TYPICAL PILE ELEVATION

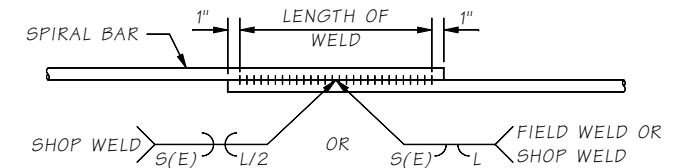
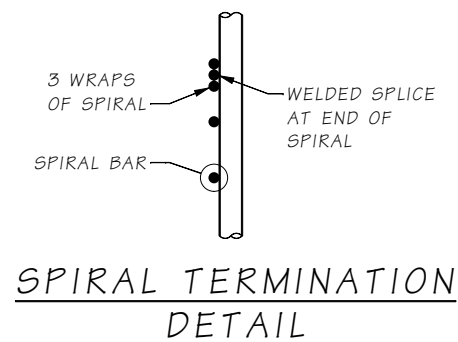
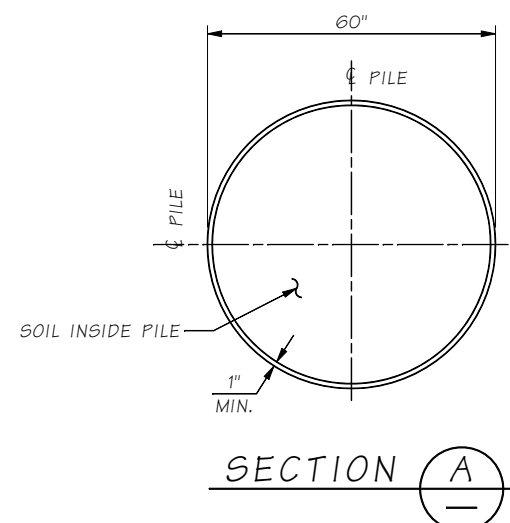
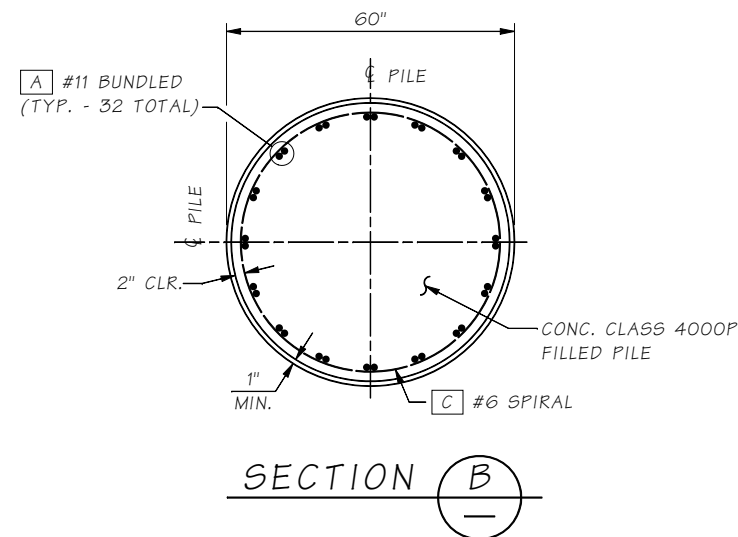

WELDED LAP SPLICE DETAIL

WELDING SHALL MEET THE REQUIREMENTS OF STD. SPEC. 6-02.3(24)E FOR WELD DIMENSIONS, SEE TABLE BELOW.

DEFORMED BAR	WELD DIMENSIONS		
	S	E	LENGTH (L)
#6	3/8	3/16	6"

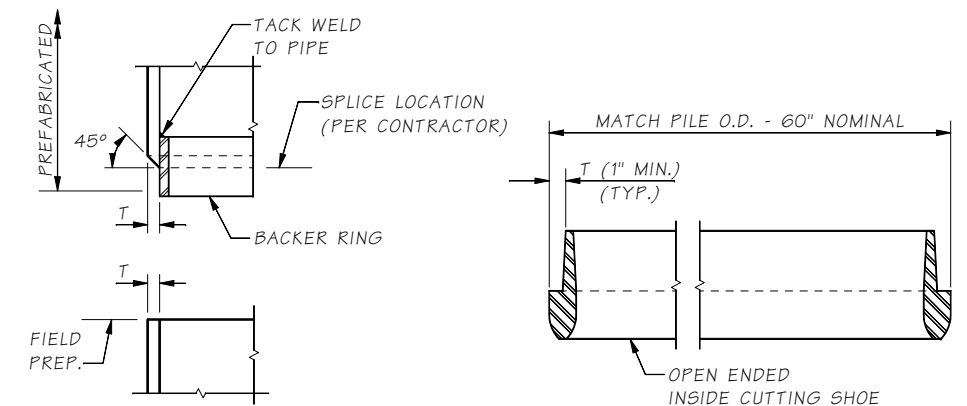

DETAIL W

PERMISSIBLE WELD SPLICE DETAILS FOR STEEL PIPE PILES. SEE "100% U.T. INSPECTION LIMITS" ON BR. SHT. BGO67 FOR WELDING INSPECTION REQUIREMENTS.

PILE TIP DETAIL

STEEL PILE WALL THICKNESS (T) AND CUTTING SHOE THICKNESS SHALL BE DETERMINED BY CONTRACTOR. SEE STD. SPEC. 6-05.3(B)

PILE BAR LIST

ALL REINFORCING SHALL BE ASTM A 706

PIER	PILES REQUIRED PER PIER	MARK	BAR SIZE	BARS PER PILE	LENGTH	BEND TYPE	WT. (LBS.) PER PILE
45	8	A	#11	32	79'-4"	STRAIGHT	13,489
		B	#6	1	(a)	SPIRAL	324
		C	#6	1	(a)	SPIRAL	777
		D	#6	1	(a)	SPIRAL	1,879
TOTAL							16,469

(a) ~ DETERMINED FROM PLANS

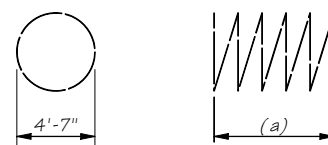

SR 99 FILE NO. SHEET BGO46

Bridge Design Engr. Khaleghi, B	M:\Y-Team\AWV SOUTH INTERCHANGE\window files\Pier 4s Pile Dtls.WND				REGION NO.	STATE	FED. AID PROJ. NO.	SHEET NO.	TOTAL SHEETS
Supervisor Moore, TM					10	WASH.			
Designed By Schultz, E	09/09								
Checked By Lee, CS	09/09								
Detailed By Hanson, CE	09/09								
Bridge Projects Engr.					JOB NUMBER				
Prelim. Plan By					09A803				
Architect/Specialist	DATE	REVISION	BY	APPD					



BRIDGE AND STRUCTURES OFFICE



SR 99
ALASKAN WAY VIADUCT - REPLACEMENT
S HOLGATE ST TO S KING ST - PHASE 2
BRIDGE NO. 99/540 NB & SB
PIER 45 PILE DETAILS

BRIDGE SHEET NO. BGO46
SHEET 892 OF 1475 SHEETS

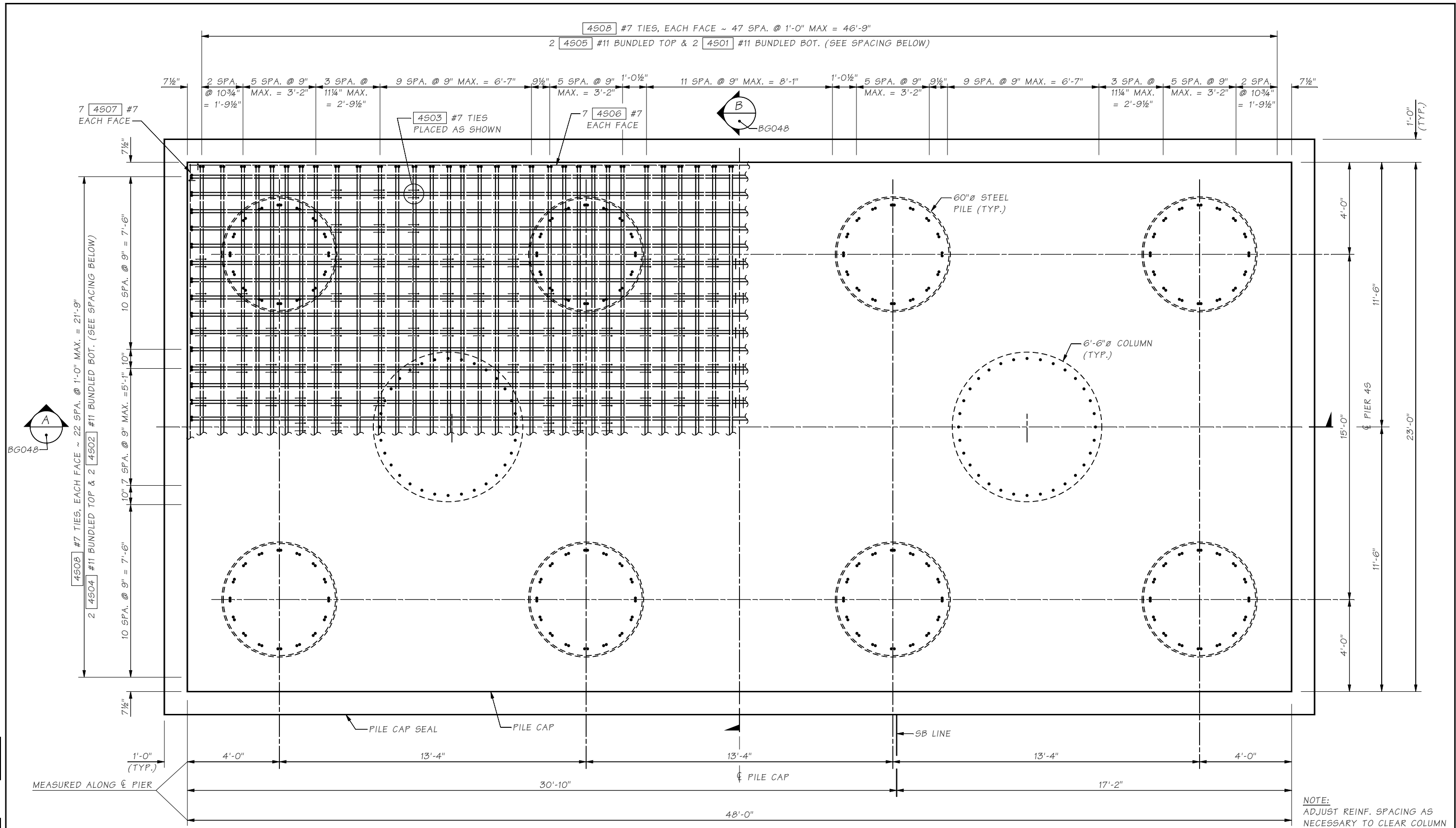

PLAN

NOTE:
ADJUST REINF. SPACING AS
NECESSARY TO CLEAR COLUMN
AND PILE VERTICAL BARS.

SR 99 FILE NO. SHEET BGO47

Bridge Design Engr.	Khaleghi, B	M:\Y-Team\AWV SOUTH INTERCHANGE\window files\Pier 4s Pile Cap Plan.WND			
Supervisor	Moore, TM	REGION NO.	STATE	FED. AID PROJ. NO.	SHEET NO.
Designed By	Schultz, E	10	WASH.		TOTAL SHEETS
Checked By	Lee, CS	JOB NUMBER			
Detailed By	Hanson, CE	09A803			
Bridge Projects Engr.		DATE	REVISION	BY	APPD
Prelim. Plan By					
Architect/Specialist					



BRIDGE AND STRUCTURES OFFICE

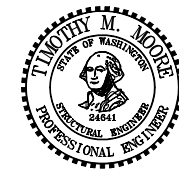

SR 99
ALASKAN WAY VIADUCT - REPLACEMENT
S HOLGATE ST TO S KING ST - PHASE 2
BRIDGE NO. 99/540 NB & SB

PIER 4S PILE CAP PLAN

BRIDGE SHEET NO. BGO47
SHEET 893 OF 1475 SHEETS

SR 99 FILE NO. SHEET BG048

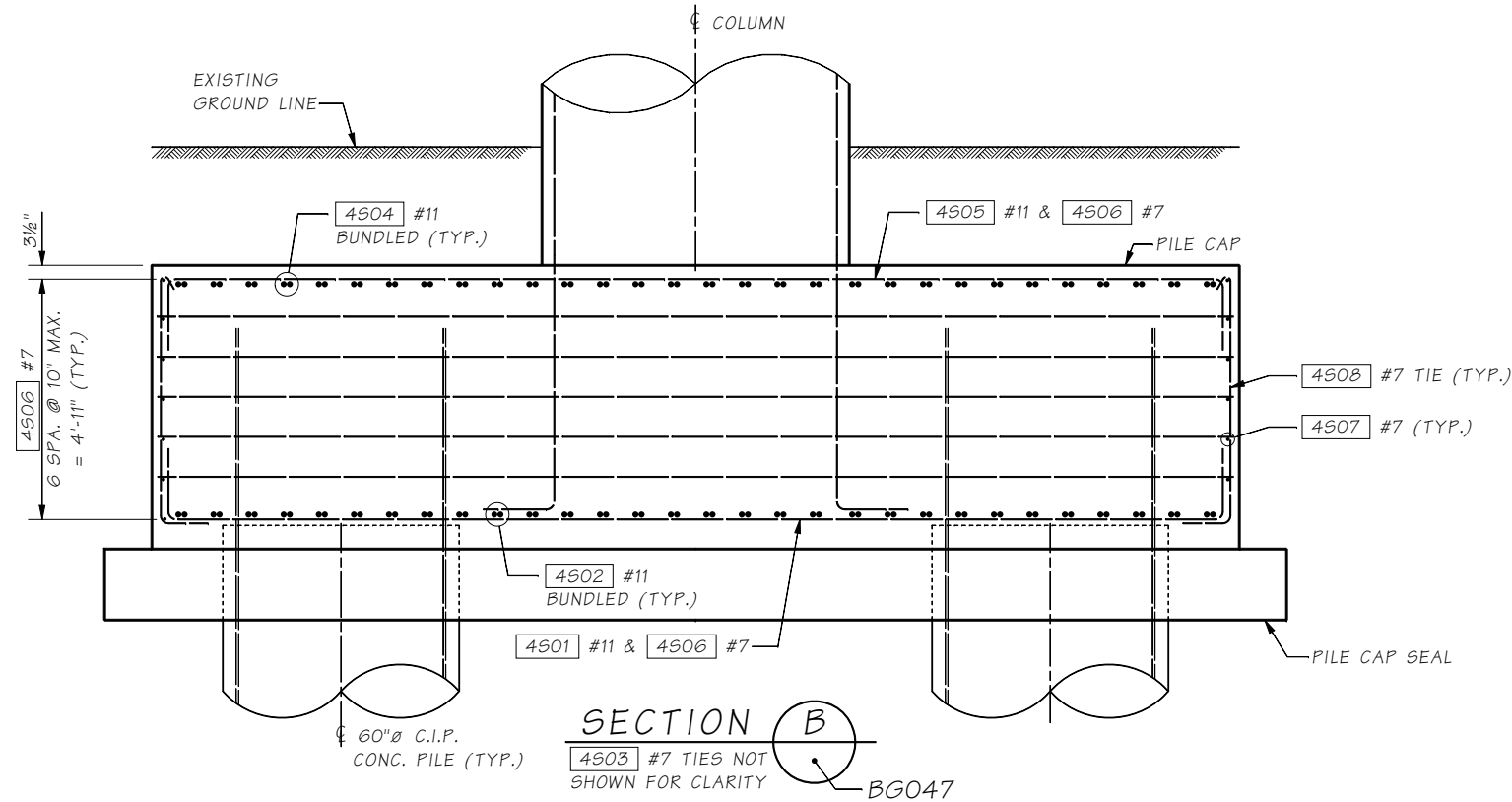

SECTION B
 4503 #7 TIES NOT SHOWN FOR CLARITY
 BGO47

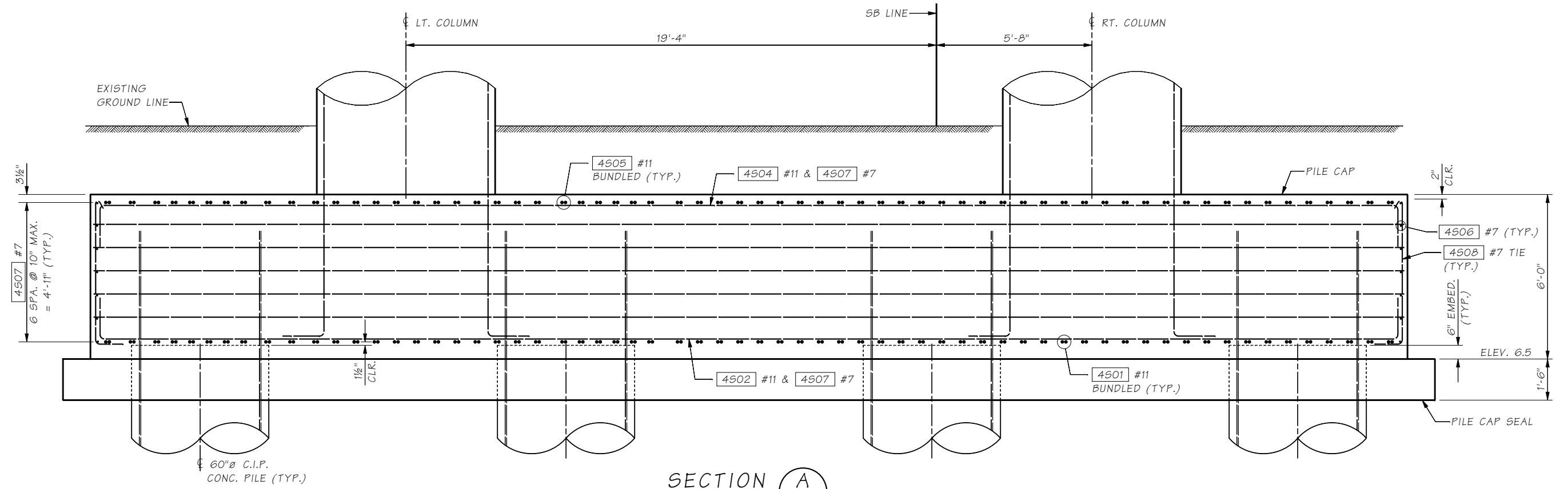

SECTION A
 4503 #7 TIES NOT SHOWN FOR CLARITY
 BGO47

Bridge Design Engr.	Khaleghi, B	M:\Y-Team\AWV SOUTH INTERCHANGE\window files\Pier 4s Pile Cap Elev.WND			
Supervisor	Moore, TM	REGION NO.	STATE	FED. AID PROJ. NO.	SHEET NO.
Designed By	Schultz, E 09/09	10	WASH.		TOTAL SHEETS
Checked By	Lee, CS 09/09	JOB NUMBER 09A803			
Detailed By	Hanson, CE 09/09				
Bridge Projects Engr.		DATE	REVISION	BY	APPD
Prelim. Plan By					
Architect/Specialist					



BRIDGE AND STRUCTURES OFFICE

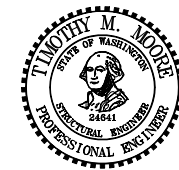

SR 99
 ALASKAN WAY VIADUCT - REPLACEMENT
 S HOLGATE ST TO S KING ST - PHASE 2
 BRIDGE NO. 99/540 NB & SB
 PIER 4S PILE CAP ELEVATION

BRIDGE SHEET NO. BGO48
 SHEET 894 OF 1475 SHEETS

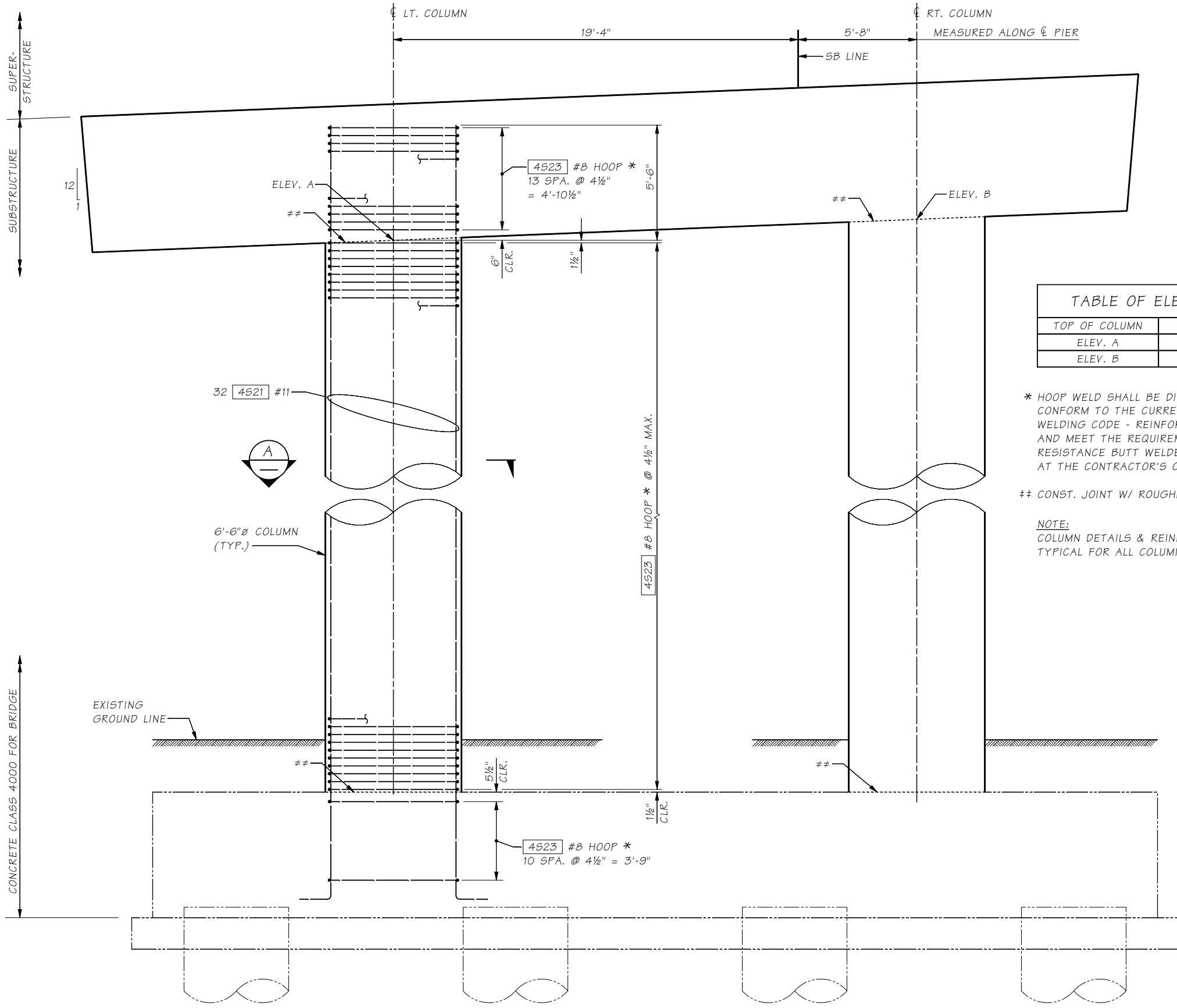
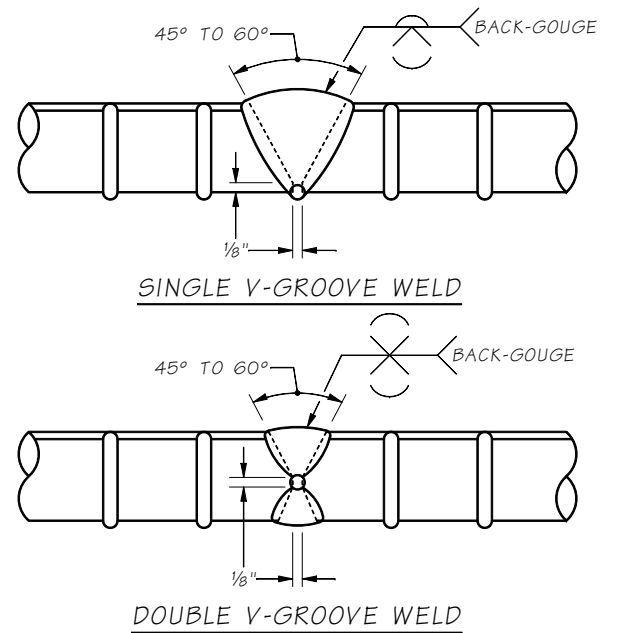
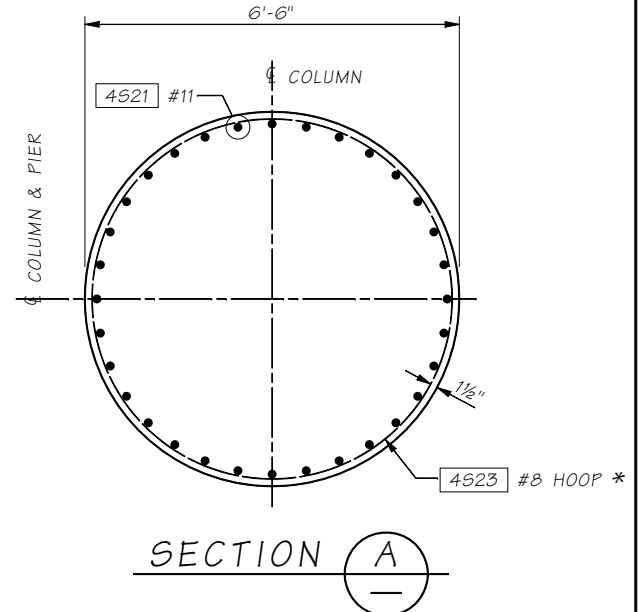

TABLE OF ELEVATIONS	
TOP OF COLUMN	ELEVATION
ELEV. A	42.96
ELEV. B	43.96

* HOOP WELD SHALL BE DIRECT BUTT-WELDED AND CONFORM TO THE CURRENT EDITION OF STRUCTURAL WELDING CODE - REINFORCING STEEL OF AWS(D1.4) AND MEET THE REQUIREMENTS OF STD. SPEC. 6-02.3(24)E. RESISTANCE BUTT WELDED SPLICE MAY BE SUBSTITUTED AT THE CONTRACTOR'S OPTION. SEE SPECIAL PROVISIONS.

** CONST. JOINT W/ ROUGHENED SURFACE

NOTE:
COLUMN DETAILS & REINFORCING TYPICAL FOR ALL COLUMNS.



HOOP WELD DETAIL
ALL BACKING SHALL BE REMOVED

COLUMN ELEVATION - PIER 4S

SR 99 FILE NO. SHEET BG049

Bridge Design Engr. Khaleghi, B	M:\Y-Team\AWV SOUTH INTERCHANGE\window files\Pier 4s Col Dtls.WND			
Supervisor Moore, TM	REGION NO.	STATE	FED. AID PROJ. NO.	SHEET TOTAL
Designed By Lee, CS 09/09	10	WASH.		
Checked By Schultz, E 09/09	JOB NUMBER 09A803			
Detailed By Hanson, CE 09/09				
Bridge Projects Engr.	DATE	REVISION	BY	APPD
Prelim. Plan By				
Architect/Specialist				



BRIDGE AND STRUCTURES OFFICE



SR 99
ALASKAN WAY VIADUCT - REPLACEMENT
S HOLGATE ST TO S KING ST - PHASE 2
BRIDGE NO. 99/540 NB & SB
PIER 4S COLUMN DETAILS

BRIDGE SHEET NO. BG049
SHEET 895 OF 1475 SHEETS

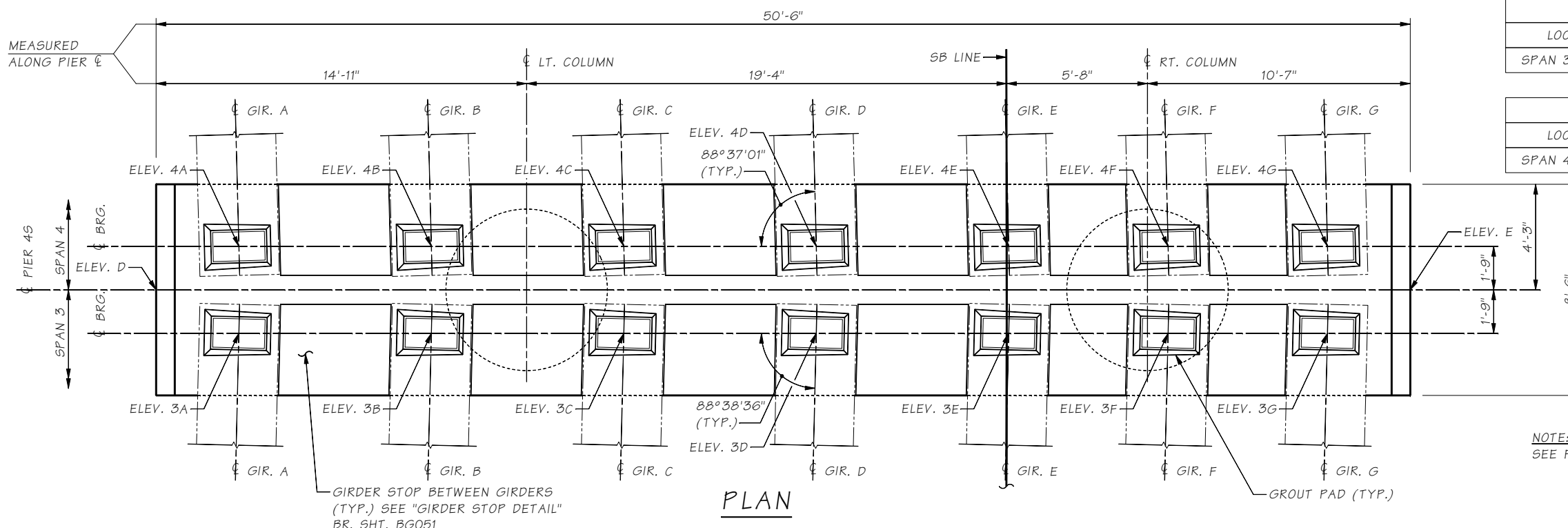
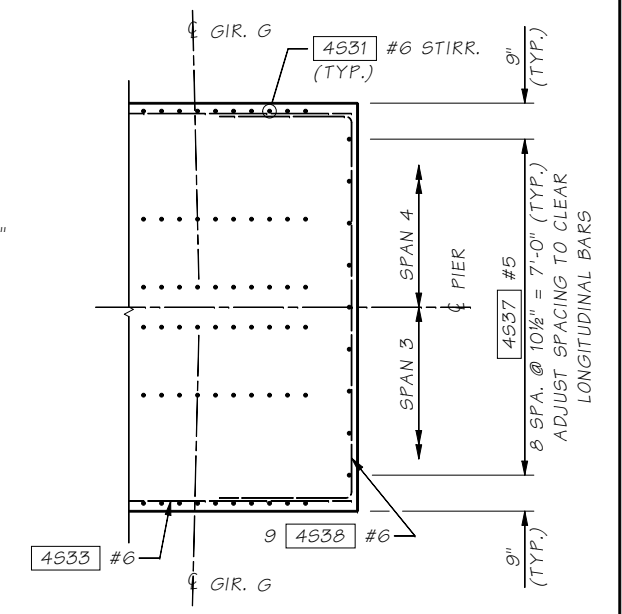
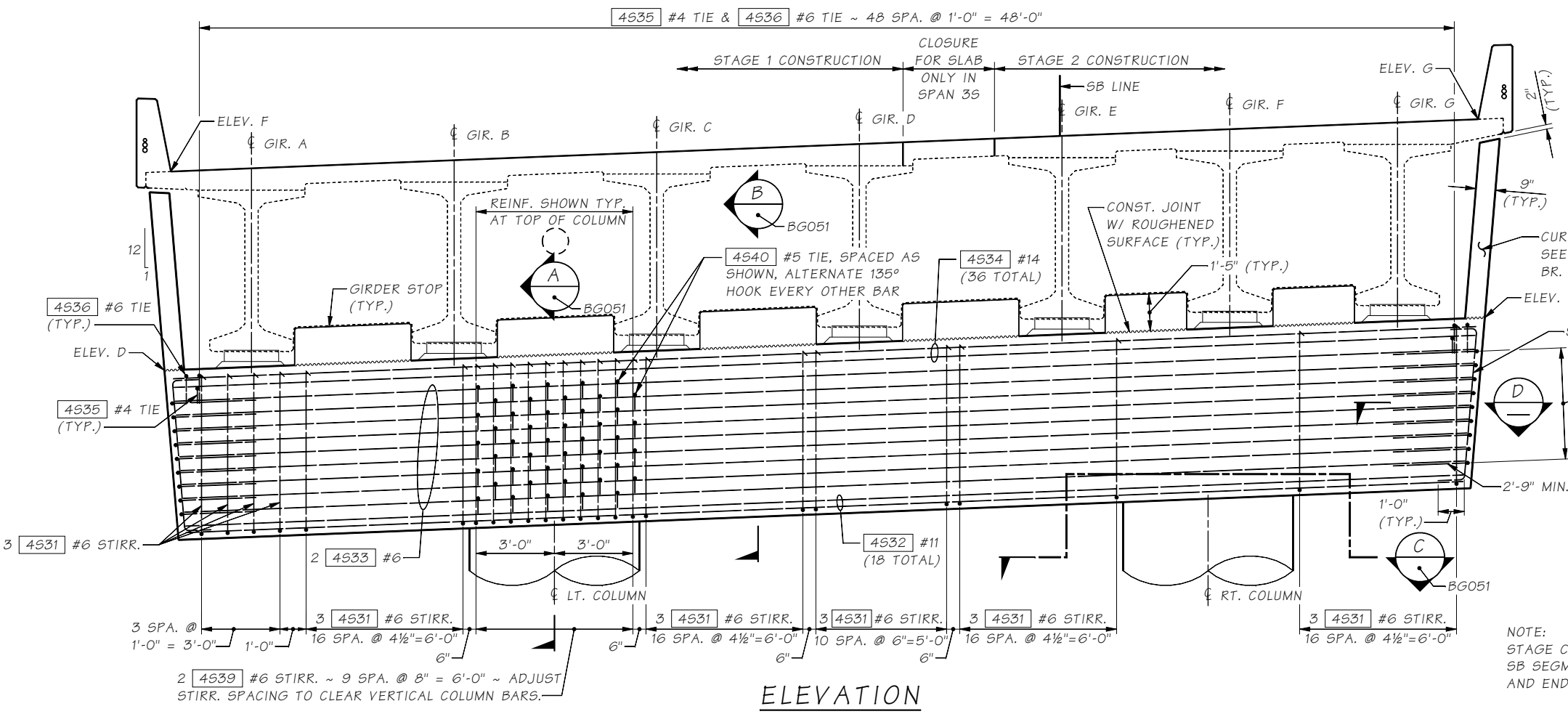

TABLE OF ELEVATIONS @ TOP OF GROUT PADS							
LOCATION	3A	3B	3C	3D	3E	3F	3G
SPAN 3 GIRDERS	49.12	49.43	49.74	50.05	50.36	50.62	50.87

TABLE OF ELEVATIONS @ TOP OF GROUT PADS							
LOCATION	4A	4B	4C	4D	4E	4F	4G
SPAN 4 GIRDERS	49.22	49.53	49.84	50.15	50.46	50.72	50.98

TABLE OF ELEVATIONS	
LOCATION	ELEVATION
D	48.86
E	50.88
F	56.47
G	58.47

NOTE:
SEE FRAMING PLAN FOR GIRDER SPACING.



NOTE:
STAGE CONSTRUCTION FOR SB SEGMENT 1 SUPERSTRUCTURE AND END DIAPHRAGM ONLY.

SR 99 FILE NO. SHEET BG050

Bridge Design Engr. Khaleghi, B	M:\Y-Team\AWV SOUTH INTERCHANGE\window files\Pier 4s X-Beam Plan-Elev.WND				
Supervisor Moore, TM	REGION NO.	STATE	FED. AID PROJ. NO.	SHEET NO.	TOTAL SHEETS
Designed By Lee, CS 10/08	10	WASH.			
Checked By Glassford, P 09/09	JOB NUMBER 09A803				
Detailed By Hanson, CE 10/08					
Bridge Projects Engr.					
Prelim. Plan By					
Architect/Specialist	DATE	REVISION	BY	APPD	



BRIDGE AND STRUCTURES OFFICE



SR 99
ALASKAN WAY VIADUCT - REPLACEMENT
S HOLGATE ST TO S KING ST - PHASE 2
BRIDGE NO. 99/540 NB & SB

PIER 45 CROSSBEAM
PLAN AND ELEVATION

BRIDGE SHEET NO. BG050
SHEET 896 OF 1475 SHEETS

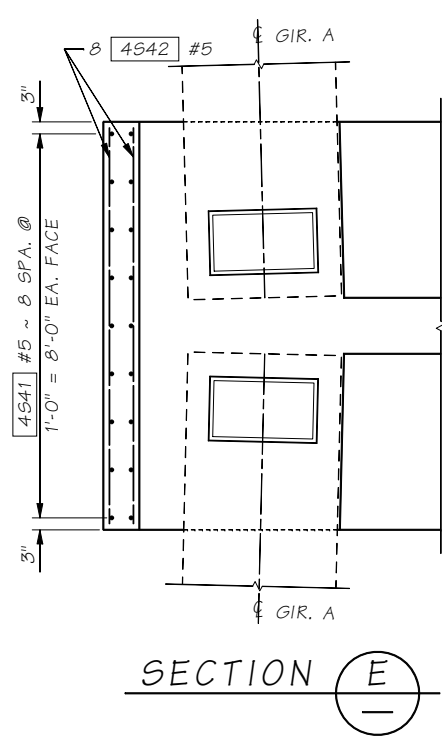

SECTION E

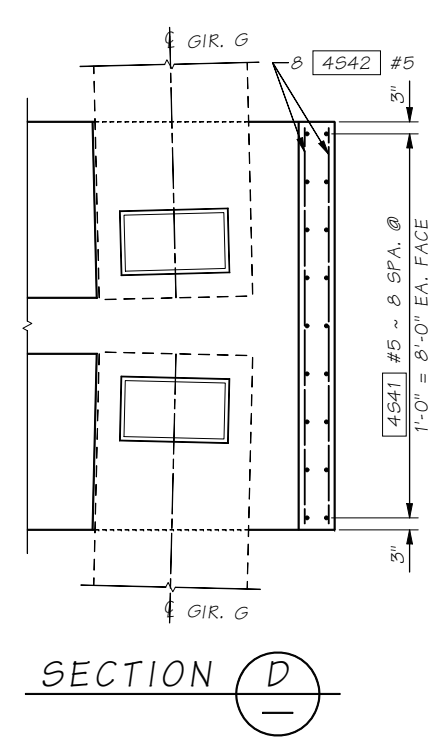

SECTION D

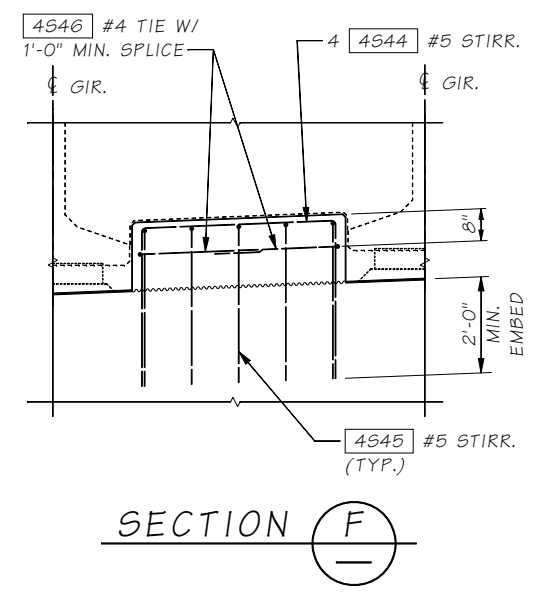

SECTION F

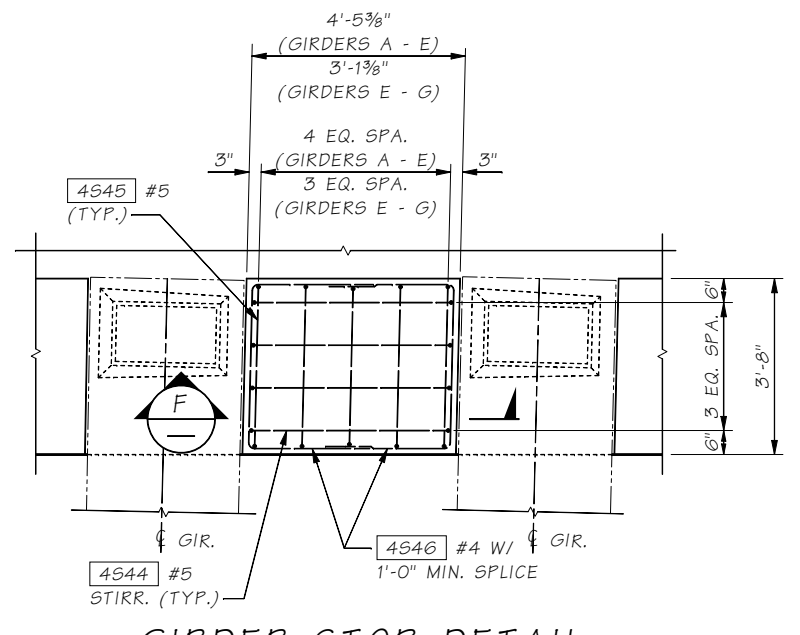

GIRDER STOP DETAIL

NOTE:
SEE "GIRDER SEAT DETAIL" BR. SHT. BG144
FOR ADDITIONAL INFORMATION.

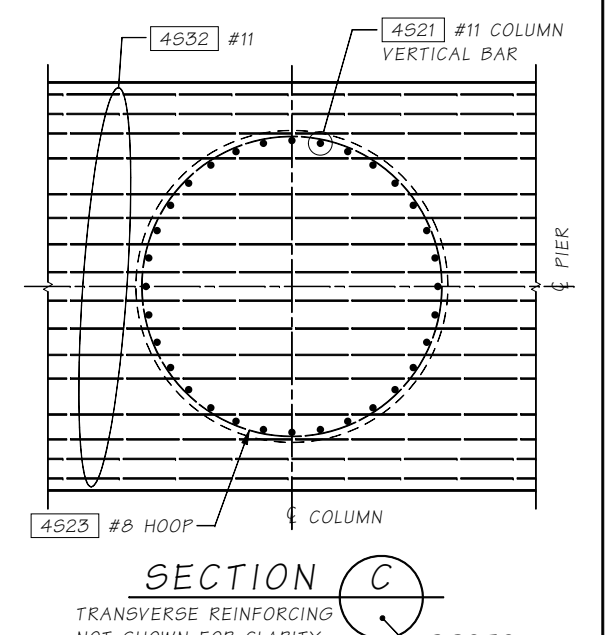

SECTION C

TRANSVERSE REINFORCING
NOT SHOWN FOR CLARITY.
ADJUST LONGITUDINAL BAR,
TRANSVERSE STIRRUP, AND THE TIE SPACING
AS REQUIRED TO CLEAR COLUMN VERTICAL BARS.

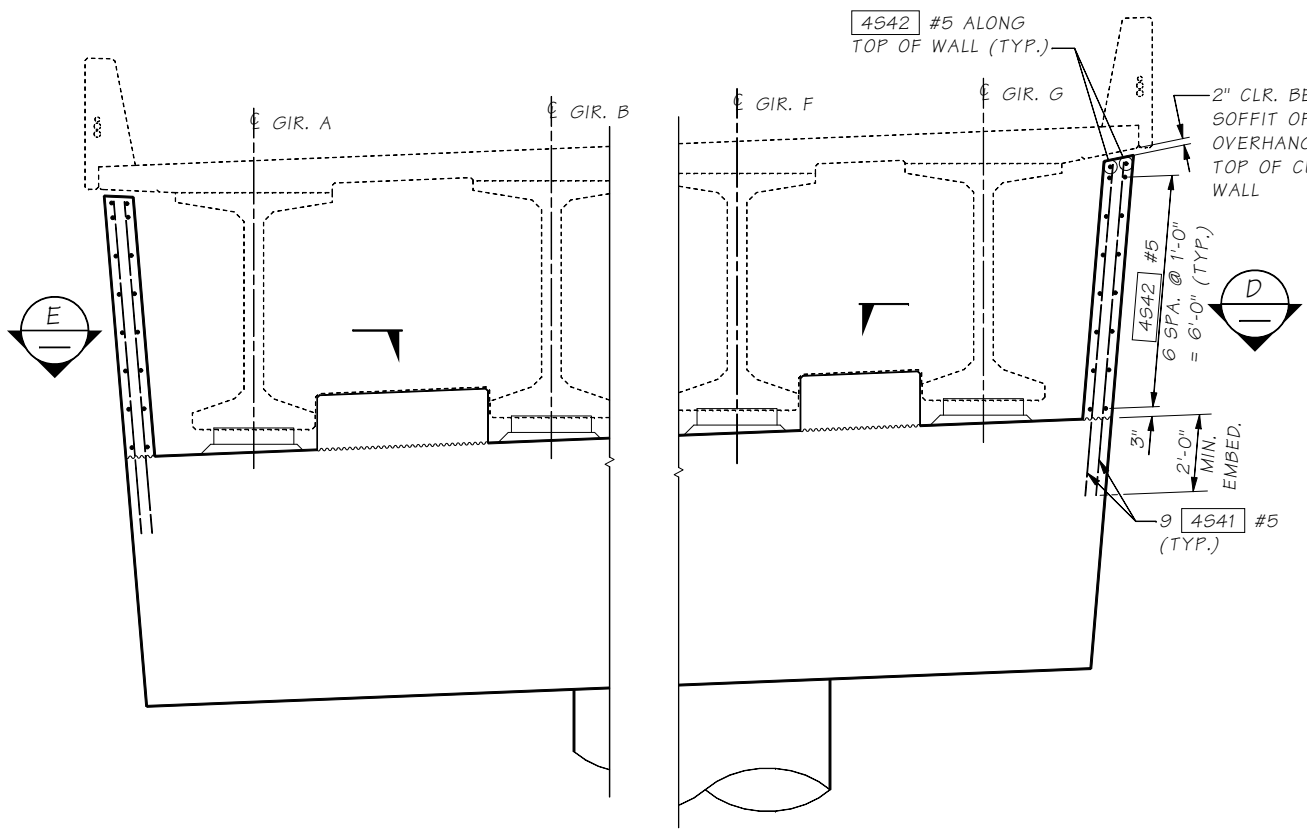

CURTAIN WALL DETAIL

CROSSBEAM REINFORCING NOT SHOWN FOR CLARITY

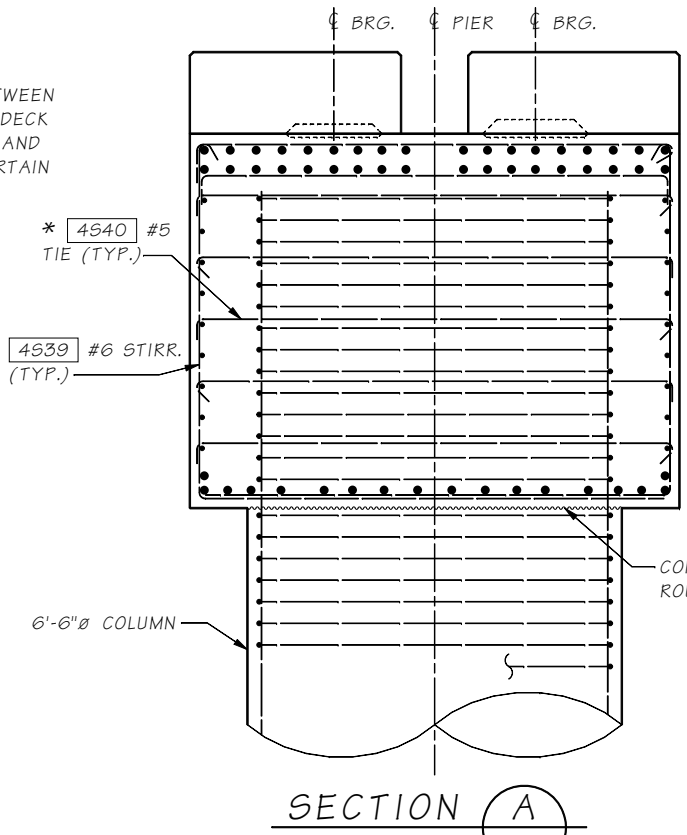

SECTION A

NOTE:
FOR DETAILS NOT
SHOWN SEE SECTION B

* ALTERNATE 135° HOOK
EVERY OTHER BAR.

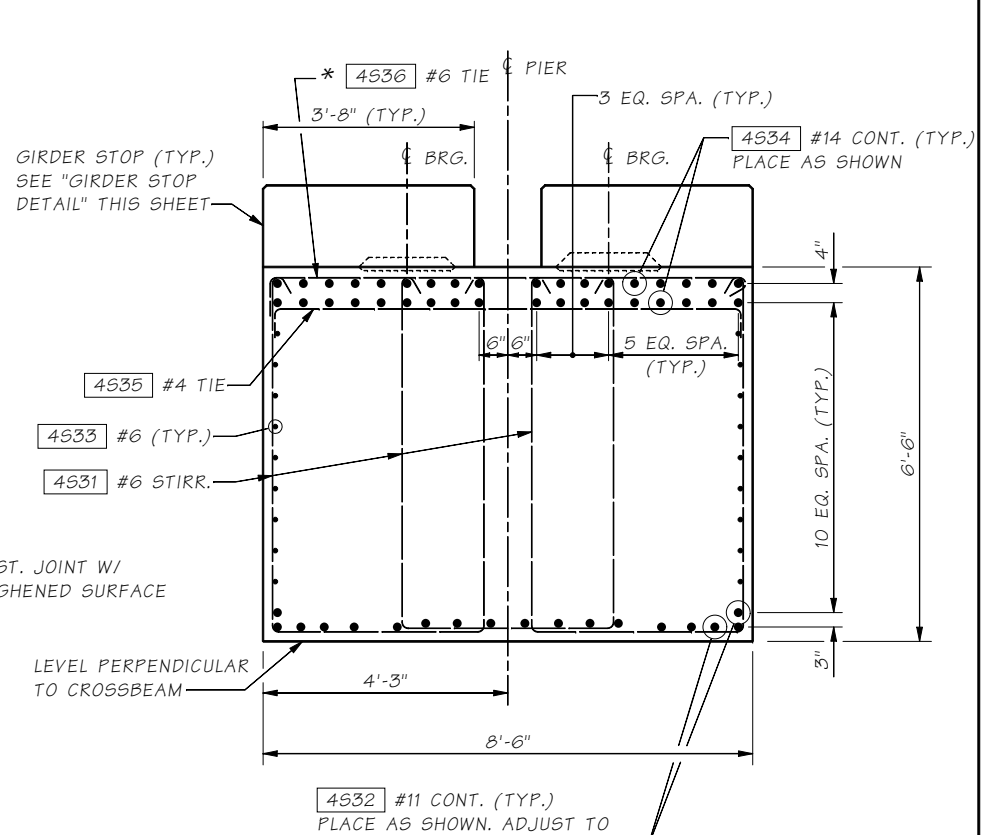

SECTION B

* ALTERNATE 135° HOOK
EVERY OTHER BAR.

SR 99 FILE NO. SHEET BG051

Bridge Design Engr. Khaleghi, B	M:\Y-Team\AWV SOUTH INTERCHANGE\window files\Pier 4s X-Beam Dtls.WND	REGION NO.	STATE	FED. AID PROJ. NO.	SHEET NO.	TOTAL SHEETS
Supervisor Moore, TM		10	WASH.			
Designed By Lee, CS	10/08					
Checked By Glassford, P	09/09					
Detailed By Hanson, CE	10/08					
Bridge Projects Engr.						
Prelim. Plan By						
Architect/Specialist	DATE	REVISION	BY	APPD		



BRIDGE AND STRUCTURES OFFICE

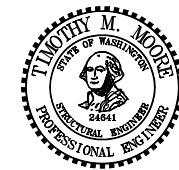

SR 99
ALASKAN WAY VIADUCT - REPLACEMENT
S HOLGATE ST TO S KING ST - PHASE 2
BRIDGE NO. 99/540 NB & SB

PIER 4S CROSSBEAM DETAILS

BRIDGE SHEET NO. BG051
SHEET 897 OF 1475 SHEETS

SR 99 FILE NO. SHEET BG052

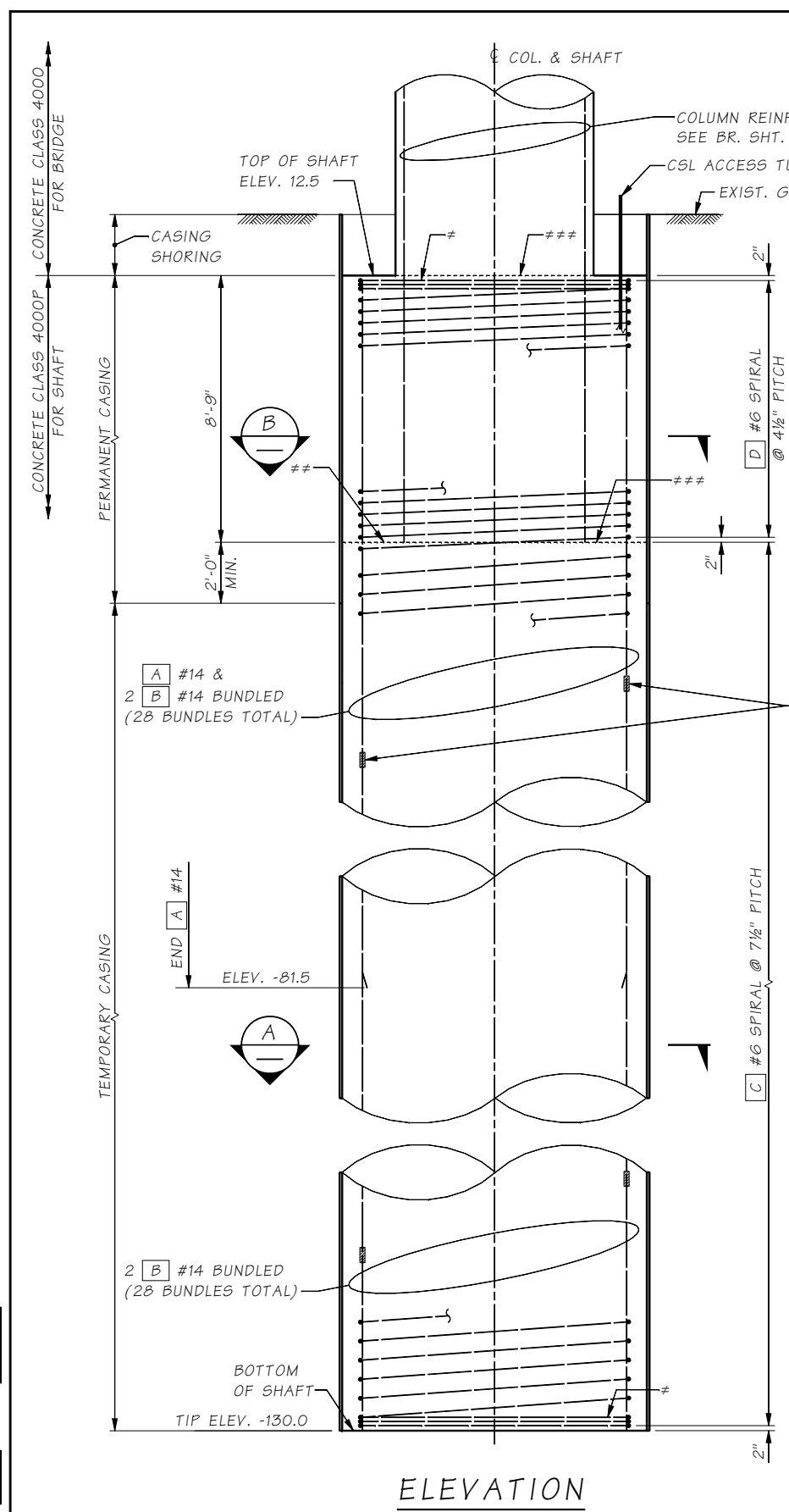

ELEVATION

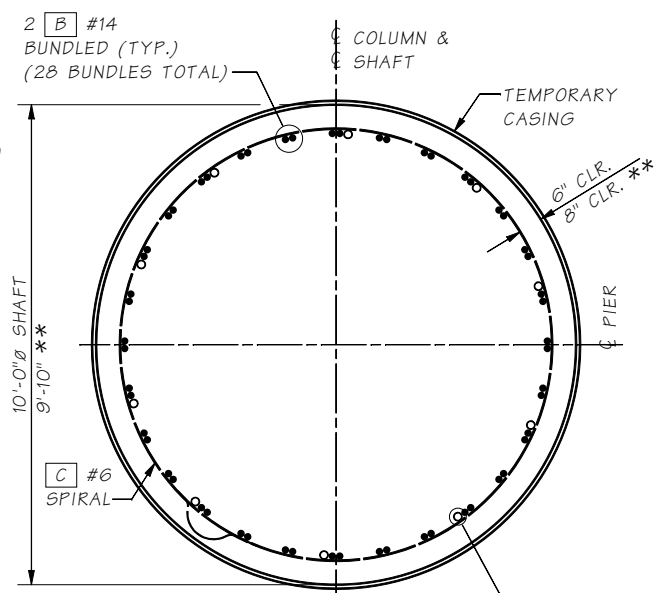

SECTION A

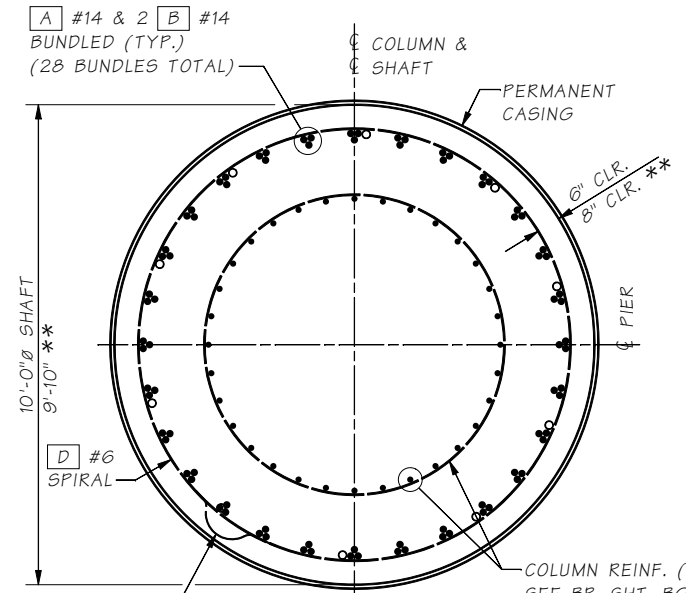

SECTION B

MECHANICAL SPLICE (TYP.) (140 TOTAL) ~ STAGGER MECHANICAL SPLICE 2'-6" VERTICALLY BETWEEN ADJACENT REBARS *

- * MECHANICAL SPLICE SHALL MEET THE REQUIREMENTS OF STD. SPEC. 6-02.3(24)F
- ** SHAFT CONSTRUCTED WITH THE OSCILLATOR METHOD. THE CONTRACTOR SHALL REVISE THE SHAFT BARLIST IF THE OSCILLATOR METHOD IS CHOSEN FOR SHAFT CONSTRUCTION
- ≠ SEE SPIRAL TERMINATION DETAIL THIS SHEET
- ** REMOVE SEDIMENT LAITANCE & WEAK CONCRETE TO SOUND CONCRETE PRIOR TO SETTING COLUMN REINFORCEMENT
- *** CONST. JOINT WITH ROUGHENED SURFACE

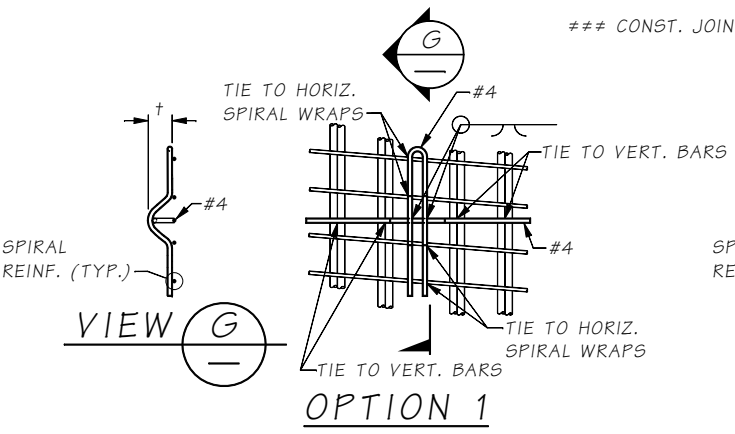

OPTION 1

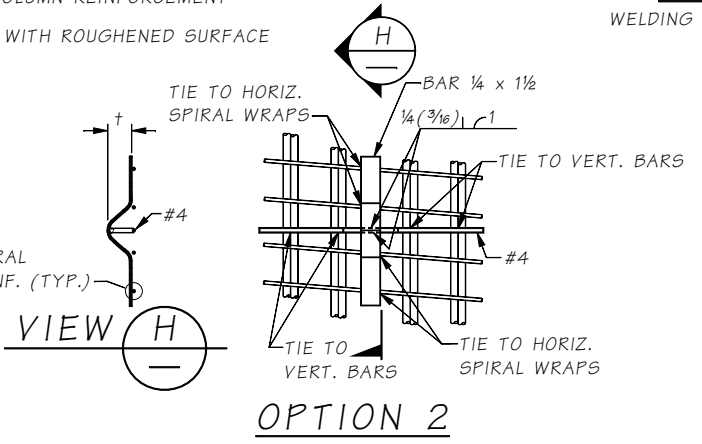

OPTION 2

CENTRALIZER DETAIL

- NOTES:
1. EPOXY COAT CENTRALIZER OR PAINT WITH INORGANIC ZINC AFTER FABRICATION.
 2. EACH LEG SHOULD BE TIED TO TWO VERTICAL BAR BUNDLES OR TWO SPIRALS.
 3. SEE SPECIAL PROVISIONS FOR SPACING REQUIREMENTS.
 4. † CONCRETE COVER MINUS 1/2"

SHAFT BAR LIST

ALL REINFORCING SHALL BE ASTM A 706
QUANTITIES ARE PER SHAFT

MARK	SIZE	NO.	LENGTH	BEND TYPE	WT. (lbs.)
A	#14	28	93'-10 1/2"	STR.	20,108
B	#14	56	142'-3"	STR.	60,940
C	#6	1	6133'-5"	67	9,212
D	#6	1	693'-10"	67	1,042
TOTAL					91,302

(a) ~ DETERMINED FROM PLANS
WEIGHT INCLUDES SPLICES
SPIRAL (BEND TYPE 67)

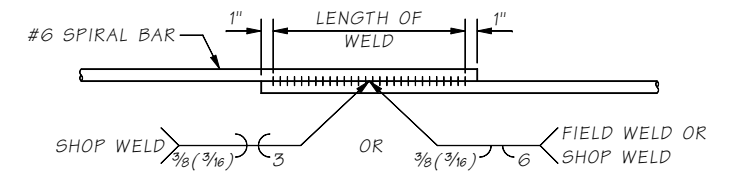

WELDED LAP SPLICE DETAIL

WELDING SHALL MEET THE REQUIREMENTS OF STD. SPEC. 6-02.3(24)E

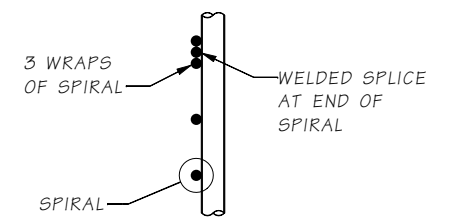

SPIRAL TERMINATION DETAIL

Bridge Design Engr. Khaleghi, B	M:\Y-Team\AWV SOUTH INTERCHANGE\window files\Pier 5s Shaft Details.WND			
Supervisor Moore, TM	REGION NO.	STATE	FED. AID PROJ. NO.	SHEET NO.
Designed By Lee, CS 10/08	10	WASH.		
Checked By Schultz, E 09/09	JOB NUMBER 09A803			
Detailed By Hanson, CE 10/08				
Bridge Projects Engr.	DATE	REVISION	BY	APPD
Prelim. Plan By				
Architect/Specialist				



BRIDGE AND STRUCTURES OFFICE

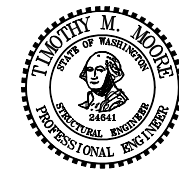

SR 99
ALASKAN WAY VIADUCT - REPLACEMENT
S HOLGATE ST TO S KING ST - PHASE 2
BRIDGE NO. 99/540 NB & SB

PIER 5S SHAFT DETAILS

BRIDGE SHEET NO. BG052
SHEET 898 OF 1475 SHEETS

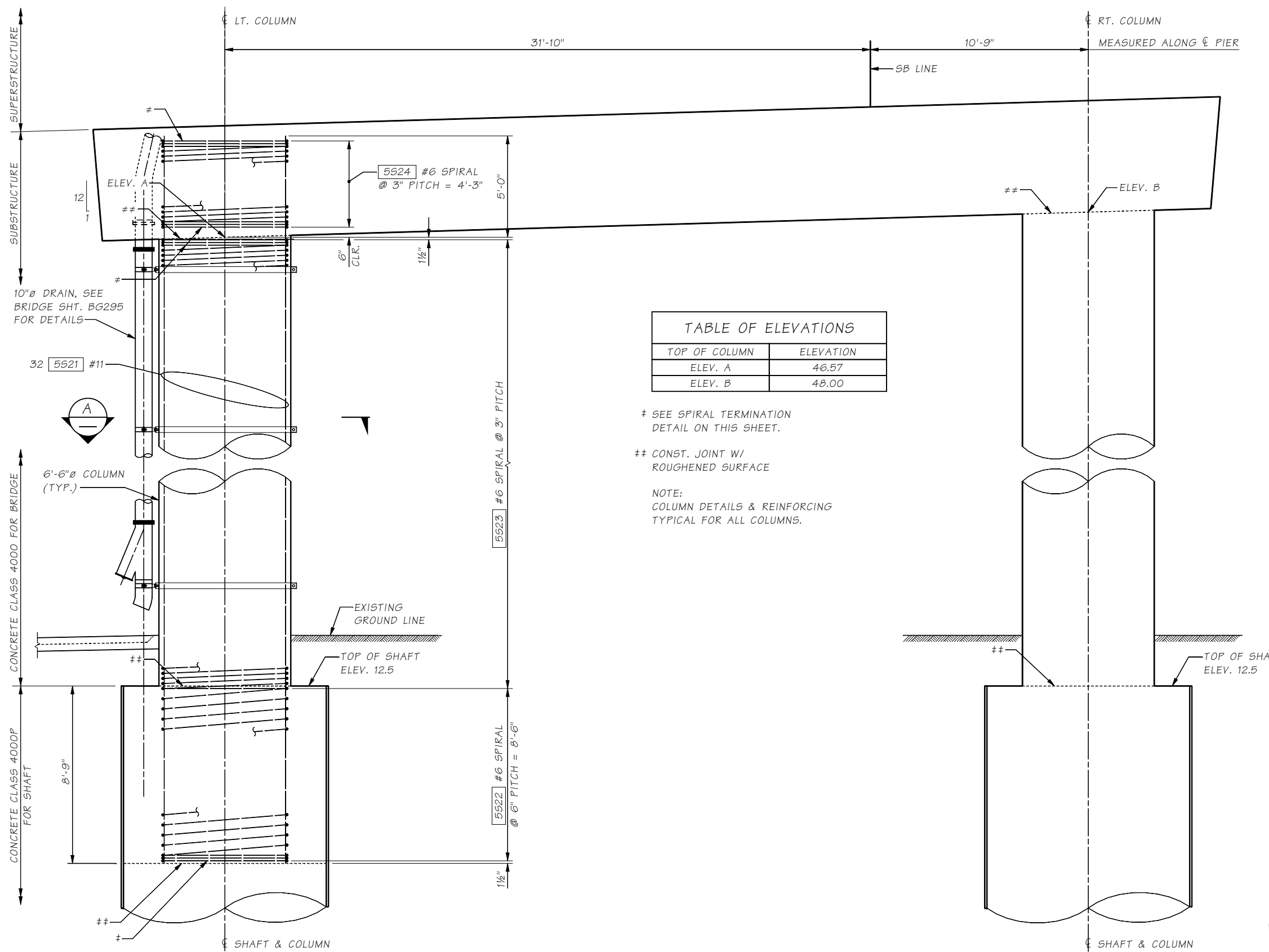
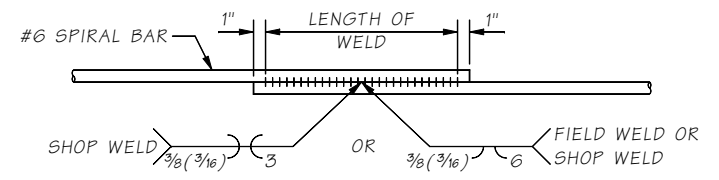
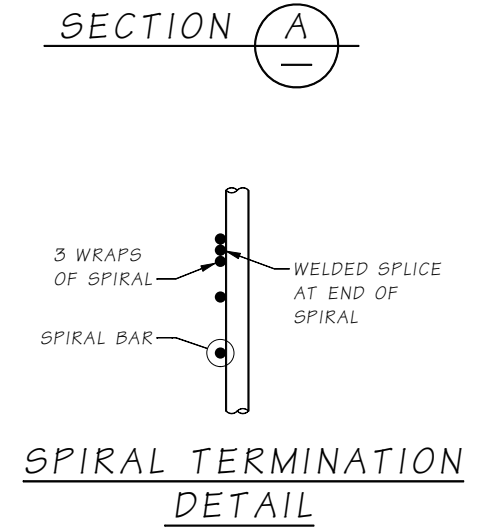
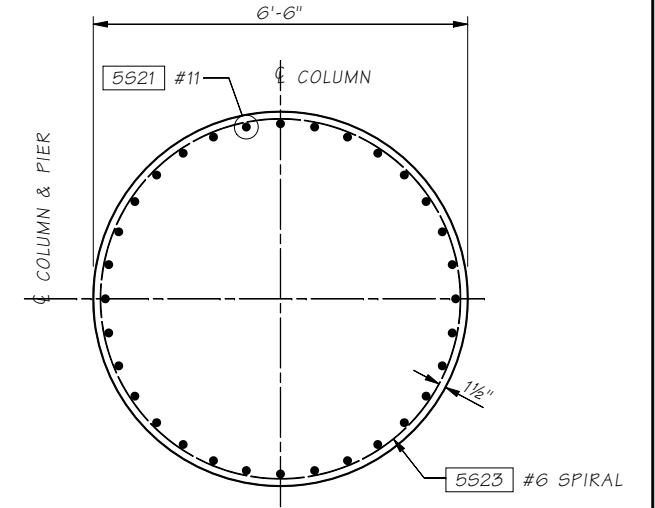

TABLE OF ELEVATIONS	
TOP OF COLUMN	ELEVATION
ELEV. A	46.57
ELEV. B	48.00

‡ SEE SPIRAL TERMINATION
DETAIL ON THIS SHEET.

‡‡ CONST. JOINT W/
ROUGHENED SURFACE

NOTE:
COLUMN DETAILS & REINFORCING
TYPICAL FOR ALL COLUMNS.



WELDED LAP SPLICE DETAIL
WELDING SHALL MEET THE REQUIREMENTS OF STD. SPEC. 6-02.3(24)E

COLUMN ELEVATION - PIER 5S

SR 99 FILE NO. SHEET BG053

Bridge Design Engr. Khaleghi, B	M:\Y-Team\AWV SOUTH INTERCHANGE\window files\Pier 5s Col Dtls.WND				REGION NO.	STATE	FED. AID PROJ. NO.	SHEET NO.	TOTAL SHEETS
Supervisor Moore, TM					10	WASH.			
Designed By Lee, CS	10/08								
Checked By Schultz, E	09/09								
Detailed By Hanson, CE	10/08								
Bridge Projects Engr.									
Prelim. Plan By									
Architect/Specialist	DATE	REVISION	BY	APPD					



BRIDGE AND STRUCTURES OFFICE

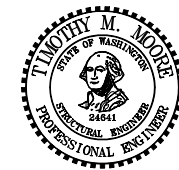

SR 99
ALASKAN WAY VIADUCT - REPLACEMENT
S HOLGATE ST TO S KING ST - PHASE 2
BRIDGE NO. 99/540 NB & SB
PIER 5S COLUMN DETAILS

BRIDGE SHEET NO. **BG053**
SHEET **899** OF **1475** SHEETS

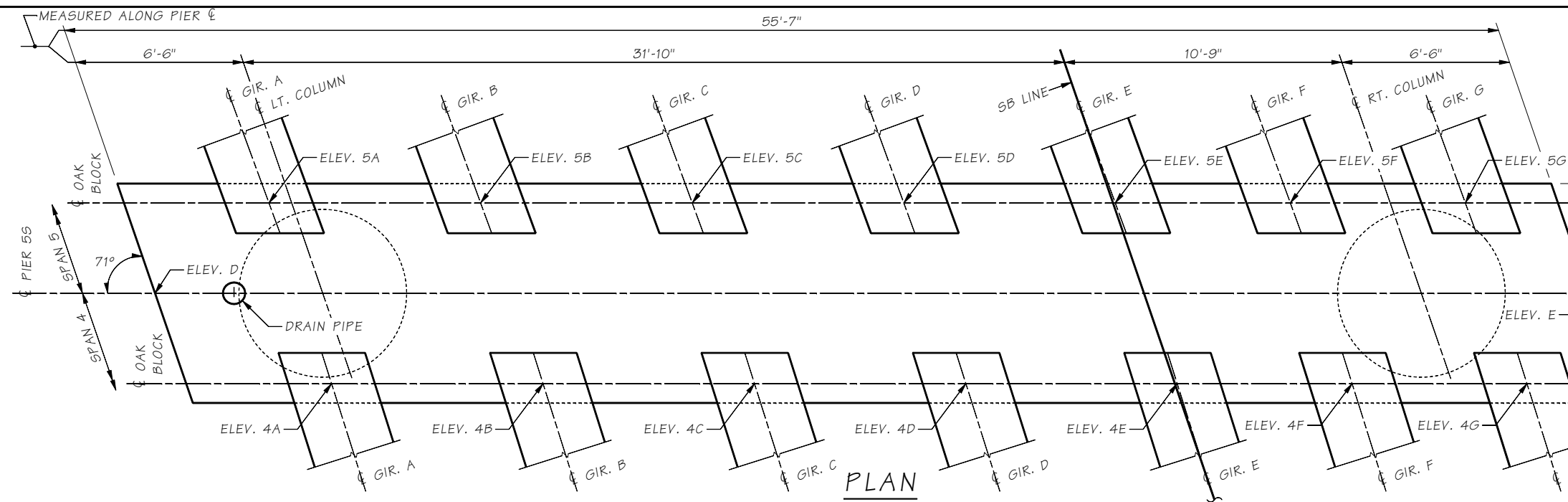

LOCATION	4A	4B	4C	4D	4E	4F	4G
SPAN 4 GIRDERS	52.39	52.66	52.94	53.21	53.48	53.71	53.93

LOCATION	5A	5B	5C	5D	5E	5F	5G
SPAN 5 GIRDERS	52.30	52.58	52.86	53.14	53.41	53.64	53.87

LOCATION	ELEVATION
D	51.85
E	53.72
F	59.34
G	61.12

NOTE:
SEE FRAMING PLAN FOR GIRDER SPACING.

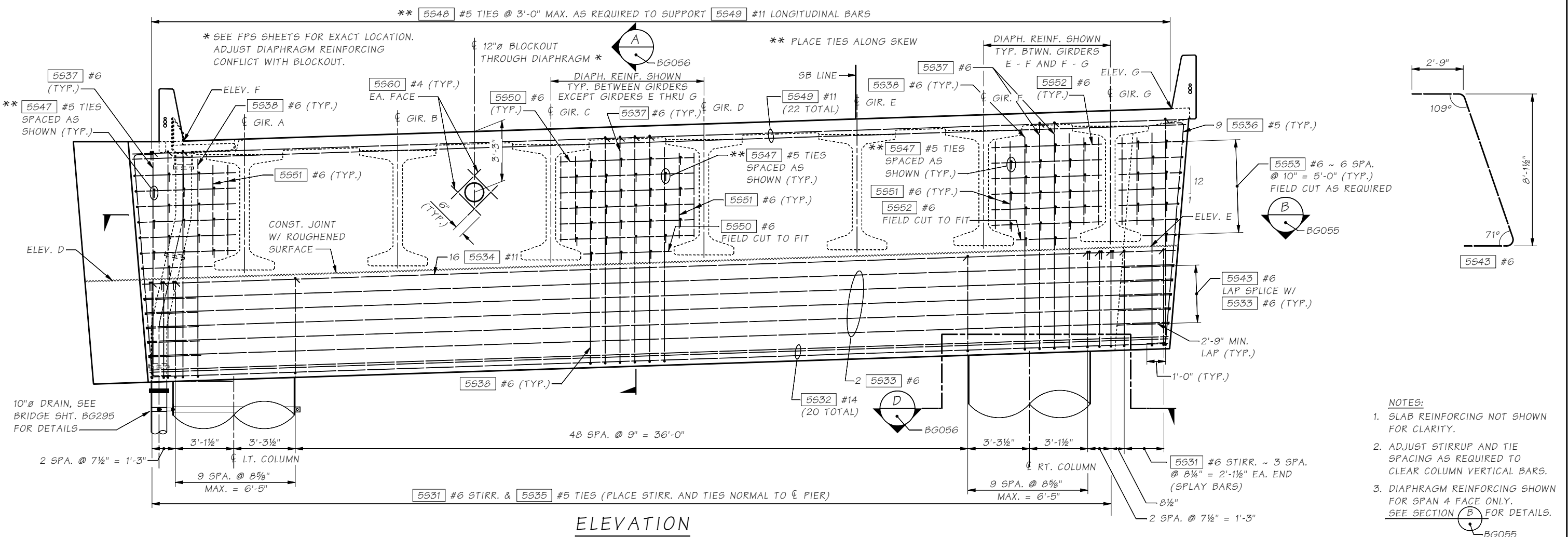

- NOTES:
1. SLAB REINFORCING NOT SHOWN FOR CLARITY.
 2. ADJUST STIRRUP AND TIE SPACING AS REQUIRED TO CLEAR COLUMN VERTICAL BARS.
 3. DIAPHRAGM REINFORCING SHOWN FOR SPAN 4 FACE ONLY. SEE SECTION (B) FOR DETAILS.

SR 99 FILE NO. SHEET BG054

Bridge Design Engr. Khaleghi, B	M:\Y-Team\AWV SOUTH INTERCHANGE\window files\Pier 55 X-Beam Plan-Elev.WND				
Supervisor Moore, TM	REGION NO.	STATE	FED. AID PROJ. NO.	SHEET NO.	TOTAL SHEETS
Designed By Lee, CS 10/08	10	WASH.			
Checked By Glassford, P 09/09	JOB NUMBER 09A803				
Detailed By Lemcke, DR 05/09					
Bridge Projects Engr.	DATE	REVISION	BY	APPD	
Prelim. Plan By					
Architect/Specialist					



BRIDGE AND STRUCTURES OFFICE

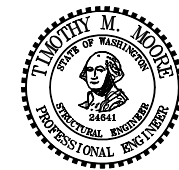

SR 99
ALASKAN WAY VIADUCT - REPLACEMENT
S HOLGATE ST TO S KING ST - PHASE 2
BRIDGE NO. 99/540 NB & SB
PIER 55 CROSSBEAM
PLAN AND ELEVATION

BRIDGE SHEET NO. BG054
SHEET 900 OF 1475 SHEETS

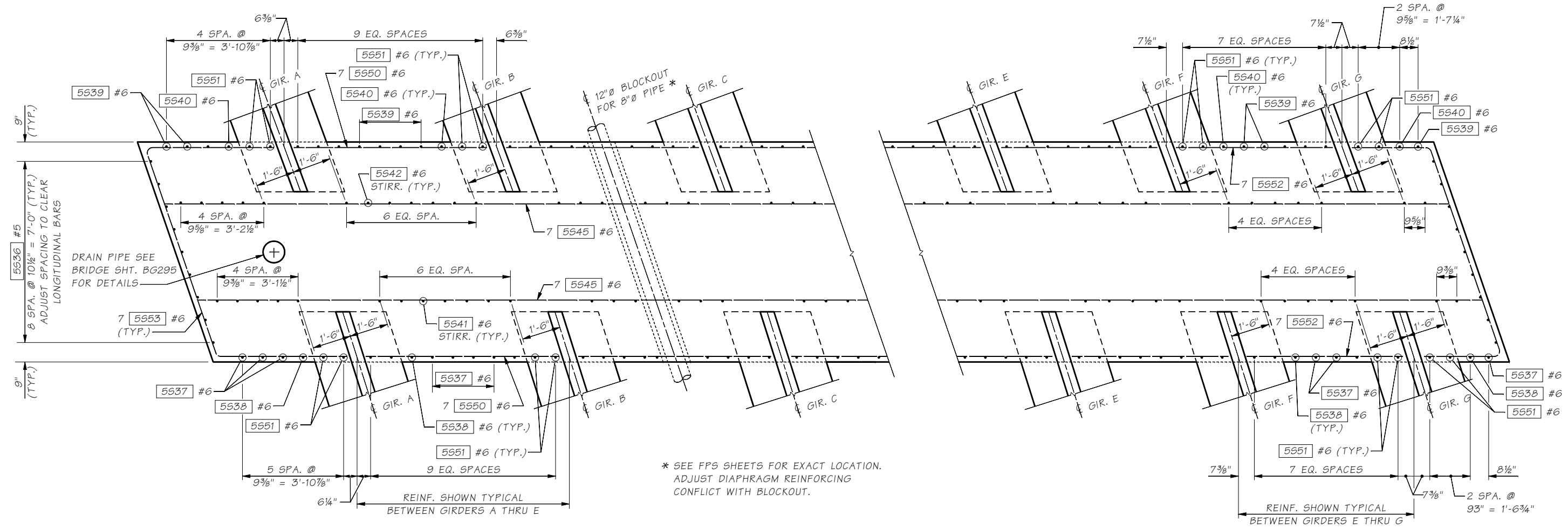

* SEE FPS SHEETS FOR EXACT LOCATION. ADJUST DIAPHRAGM REINFORCING CONFLICT WITH BLOCKOUT.

SECTION B
BG054

Bridge Design Engr.	Khaleghi, B	M:\Y-Team\AWV SOUTH INTERCHANGE\window files\Pier 5s X-Beam Dtls.WND			
Supervisor	Moore, TM	REGION NO.	STATE	FED. AID PROJ. NO.	SHEET NO.
Designed By	Lee, CS	10	WASH.		TOTAL SHEETS
Checked By	Glassford, P	JOB NUMBER			
Detailed By	Lemcke, DR	09A803			
Bridge Projects Engr.		DATE	REVISION	BY	APPD
Prelim. Plan By					
Architect/Specialist					



BRIDGE AND STRUCTURES OFFICE

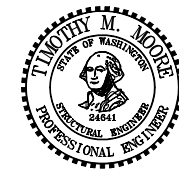

SR 99
ALASKAN WAY VIADUCT - REPLACEMENT
S HOLGATE ST TO S KING ST - PHASE 2
BRIDGE NO. 99/540 NB & SB
PIER 5S CROSSBEAM DETAILS 1 OF 2

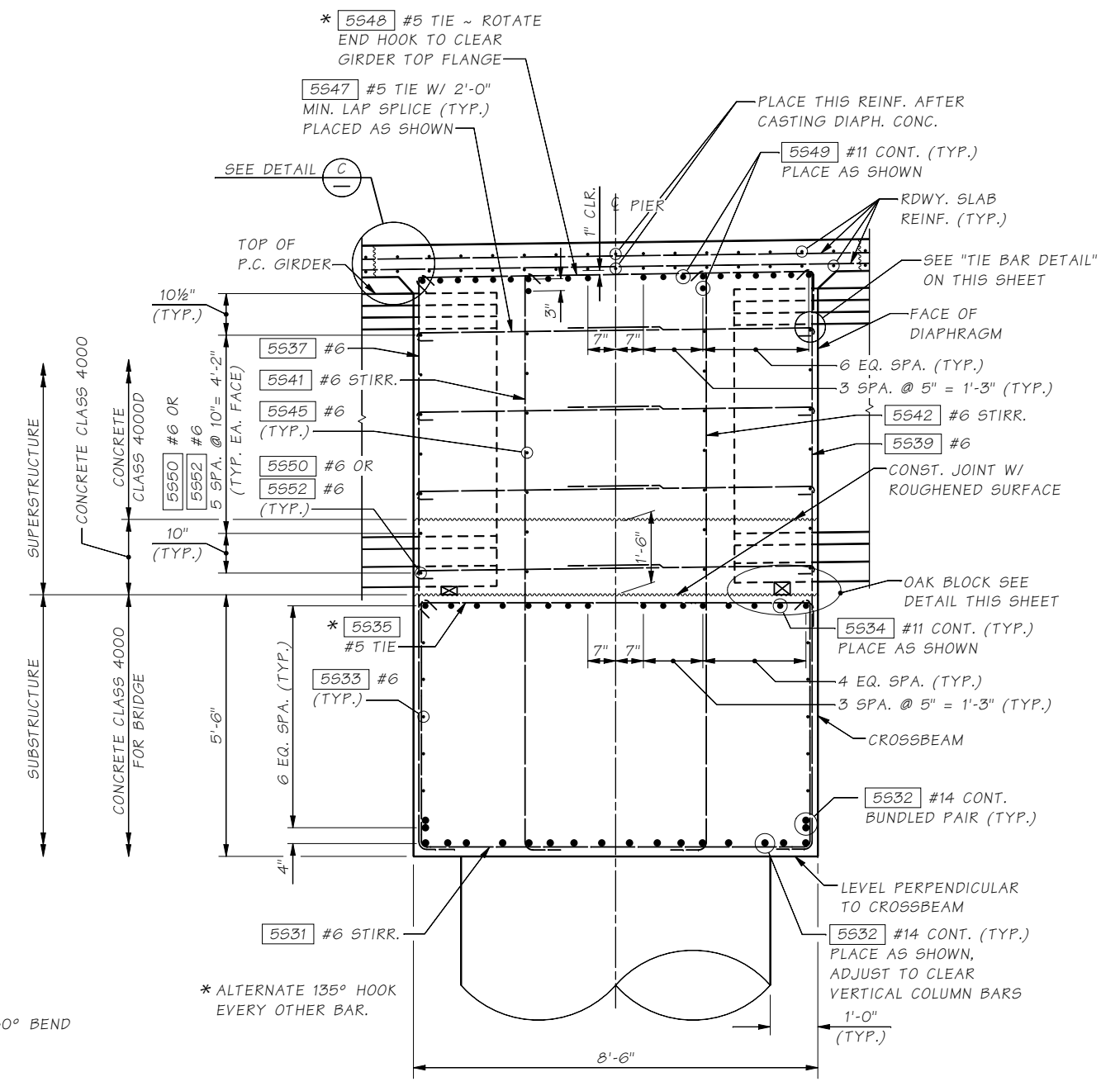
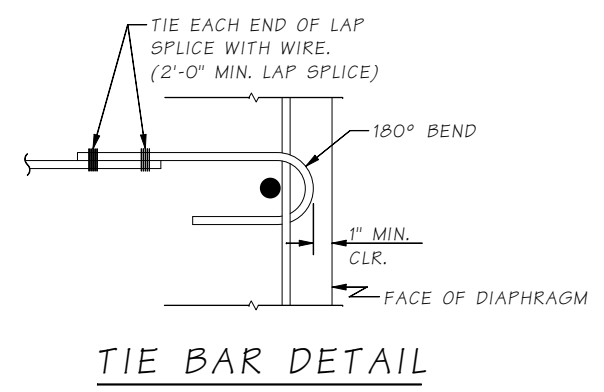
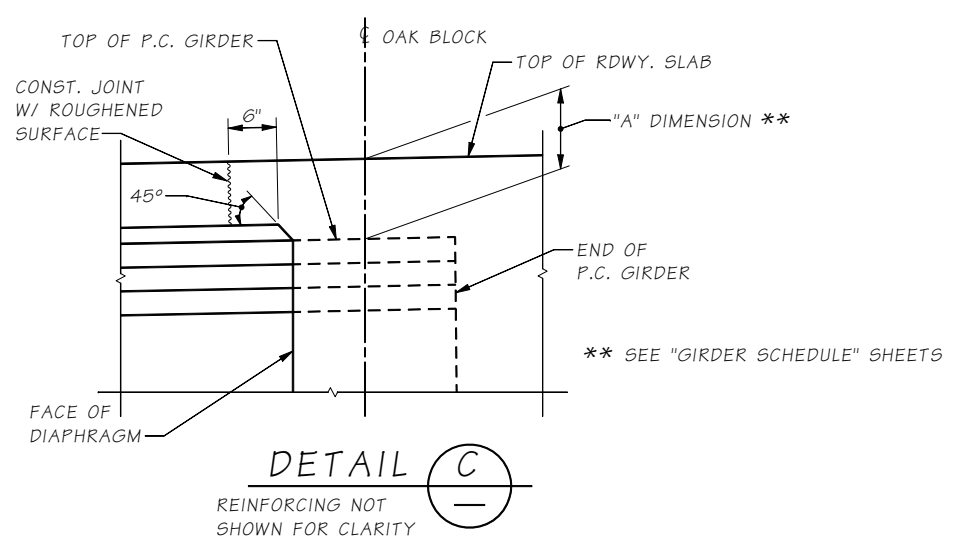
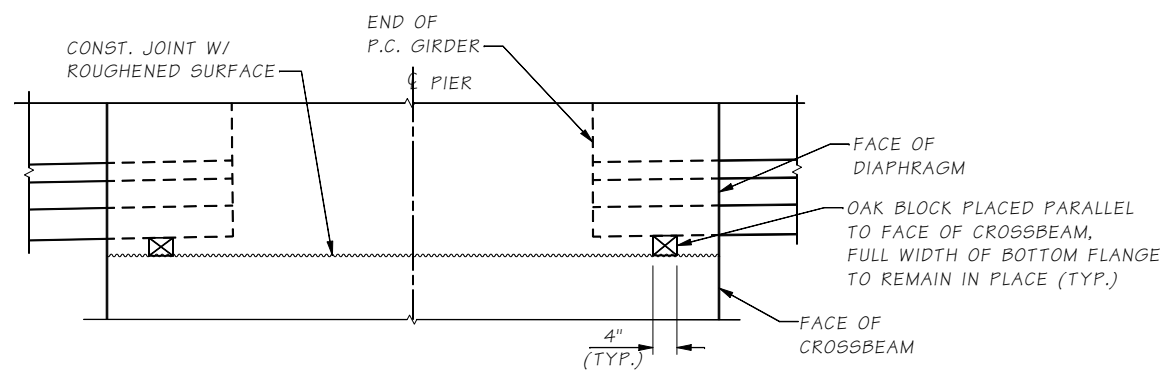
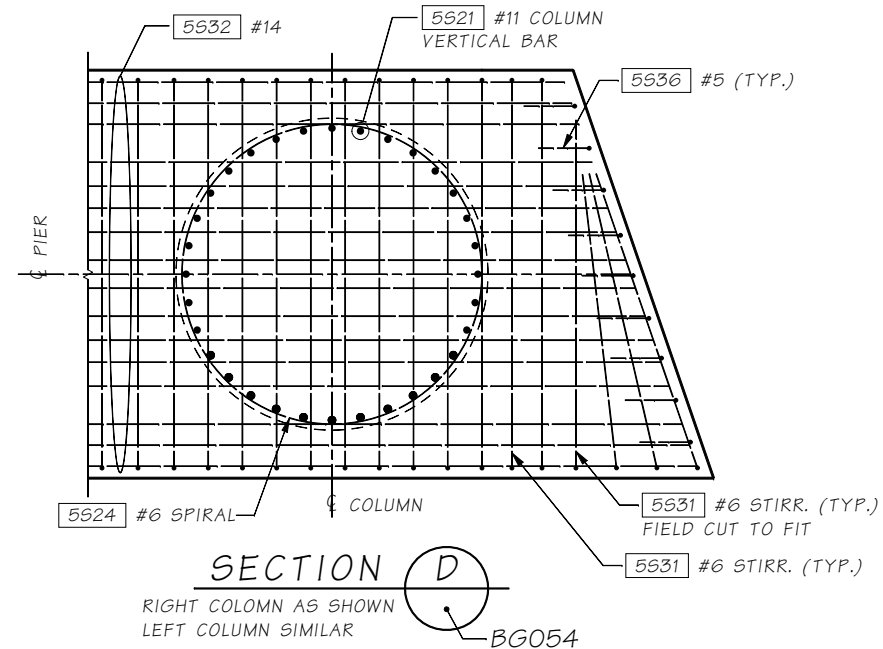

SECTION A

NOTES:
1. LONGITUDINAL DIMENSIONS ARE NORMAL TO SKEW.
2. FOR CONCRETE PLACEMENT PROCEDURE, SEE "CONSTRUCTION SEQUENCE" SHEET.

SR 99 FILE NO. SHEET BG056

Bridge Design Engr.	Khaleghi, B	M:\Y-Team\AWV SOUTH INTERCHANGE\window files\Pier 5S X-Beam Dtls 2.WND			
Supervisor	Moore, TM	REGION NO.	STATE	FED. AID PROJ. NO.	SHEET NO.
Designed By	Lee, CS 05/09	10	WASH.		TOTAL SHEETS
Checked By	Glassford, P 09/09	JOB NUMBER			
Detailed By	Lemcke, DR 05/09	09A803			
Bridge Projects Engr.		DATE	REVISION	BY	APPD
Prelim. Plan By					
Architect/Specialist					



BRIDGE AND STRUCTURES OFFICE

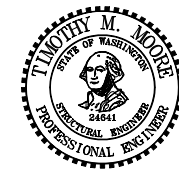

SR 99
ALASKAN WAY VIADUCT - REPLACEMENT
S HOLGATE ST TO S KING ST - PHASE 2
BRIDGE NO. 99/540 NB & SB
PIER 5S CROSSBEAM DETAILS 2 OF 2

BRIDGE SHEET NO. BG056
SHEET 902 OF 1475 SHEETS

SR 99 FILE NO. SHEET BG057

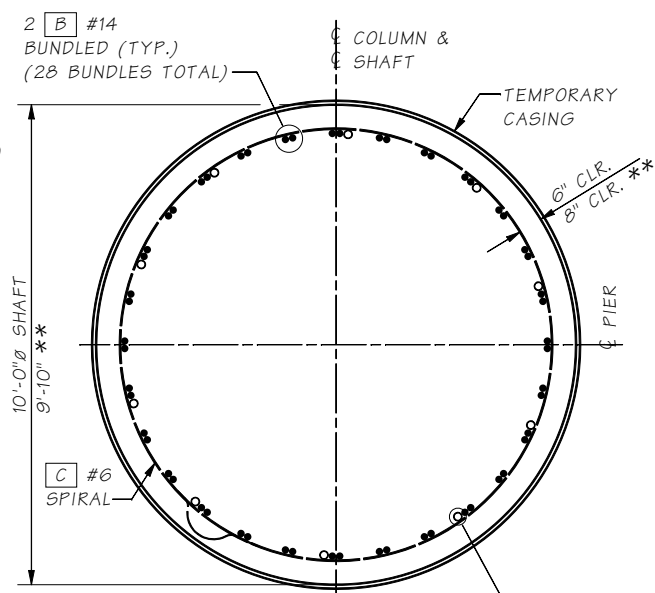
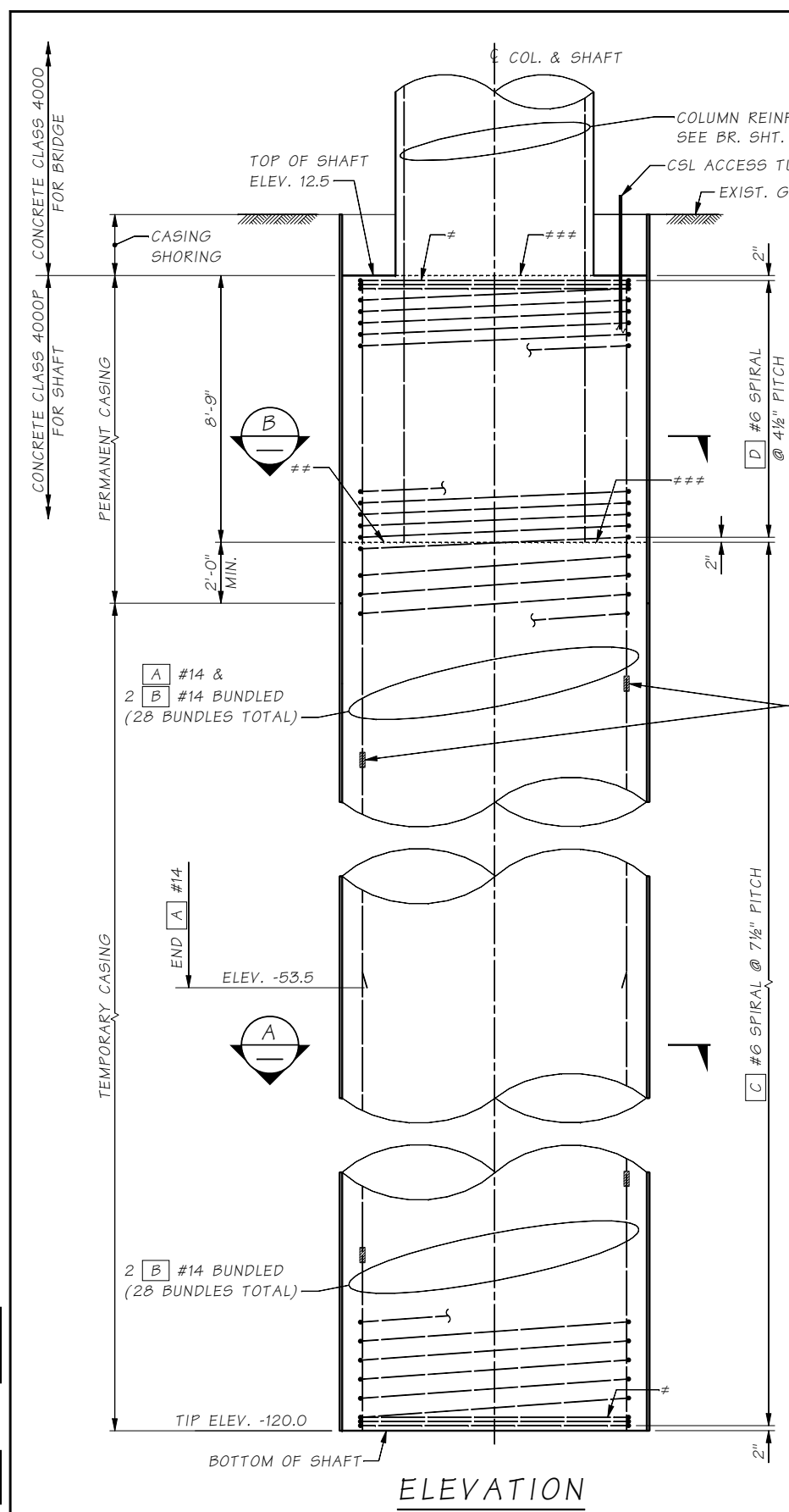

SECTION A

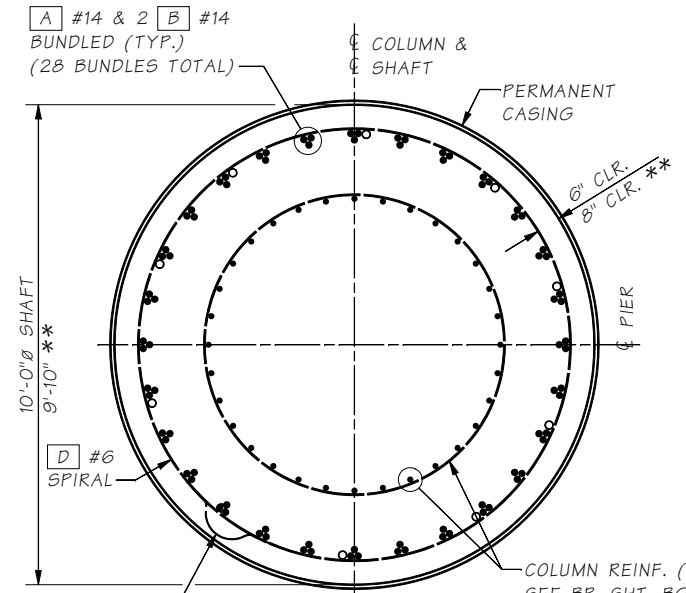

SECTION B

SHAFT BAR LIST					
ALL REINFORCING SHALL BE ASTM A 706 QUANTITIES ARE PER SHAFT					
MARK	SIZE	NO.	LENGTH	BEND TYPE	WT. (lbs.)
A	#14	28	65'-10 1/2"	STR.	14,110
B	#14	56	132'-3"	STR.	56,656
C	#6	1	5323'-0"	67	7,995
D	#6	1	693'-10"	67	1,042
TOTAL					79,803

(a) ~ DETERMINED FROM PLANS
WEIGHT INCLUDES SPLICES
SPIRAL (BEND TYPE 67)

MECHANICAL SPLICE (TYP.) (140 TOTAL) ~ STAGGER MECHANICAL SPLICE 2'-6" VERTICALLY BETWEEN ADJACENT REBARS *

- * MECHANICAL SPLICE SHALL MEET THE REQUIREMENTS OF STD. SPEC. 6-02.3(24)F
- ** SHAFT CONSTRUCTED WITH THE OSCILLATOR METHOD. THE CONTRACTOR SHALL REVISE THE SHAFT BARLIST IF THE OSCILLATOR METHOD IS CHOSEN FOR SHAFT CONSTRUCTION
- # SEE SPIRAL TERMINATION DETAIL THIS SHEET
- ** REMOVE SEDIMENT LAITANCE & WEAK CONCRETE TO SOUND CONCRETE PRIOR TO SETTING COLUMN REINFORCEMENT
- *** CONST. JOINT W/ ROUGHENED SURFACE

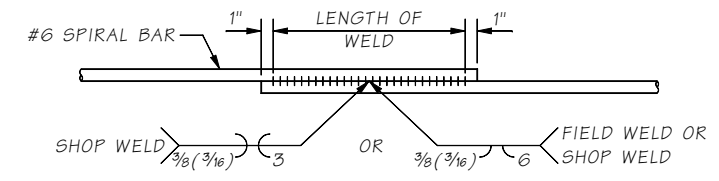

WELDED LAP SPLICE DETAIL
WELDING SHALL MEET THE REQUIREMENTS OF STD. SPEC. 6-02.3(24)E

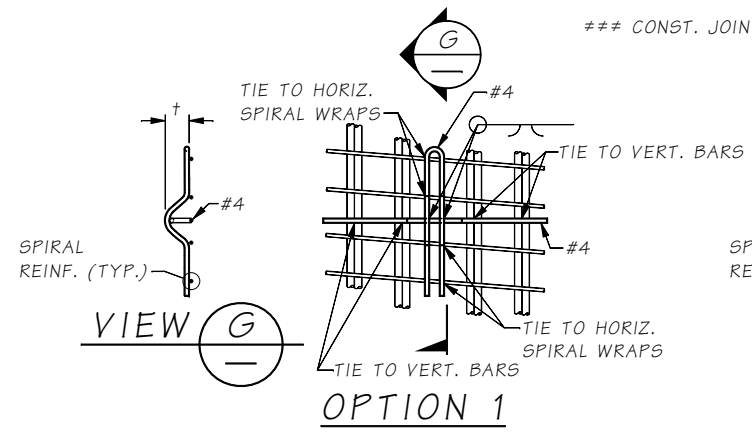

OPTION 1

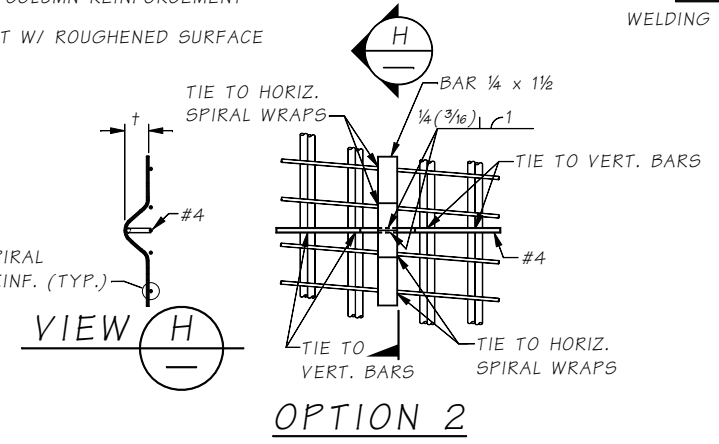

OPTION 2

CENTRALIZER DETAIL

- NOTES:
- EPOXY COAT CENTRALIZER OR PAINT WITH INORGANIC ZINC AFTER FABRICATION.
 - EACH LEG SHOULD BE TIED TO TWO VERTICAL BAR BUNDLES OR TWO SPIRALS.
 - SEE SPECIAL PROVISIONS FOR SPACING REQUIREMENTS.
 - + CONCRETE COVER MINUS 1/2"

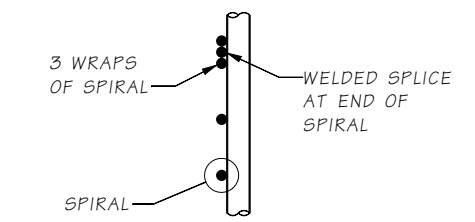

SPIRAL TERMINATION DETAIL

Bridge Design Engr. Khaleghi, B	M:\Y-Team\AWV SOUTH INTERCHANGE\window files\Pier 6s Shaft Dtl's.WND	REGION NO.	STATE	FED. AID PROJ. NO.	SHEET NO.	TOTAL SHEETS
Supervisor Moore, TM		10	WASH.			
Designed By Lee, CS	10/08	JOB NUMBER 09A803				
Checked By Schultz, E	09/09					
Detailed By Hanson, CE	10/08					
Bridge Projects Engr.						
Prelim. Plan By						
Architect/Specialist	DATE	REVISION	BY	APPD		



BRIDGE AND STRUCTURES OFFICE

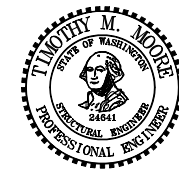

SR 99
ALASKAN WAY VIADUCT - REPLACEMENT
S HOLGATE ST TO S KING ST - PHASE 2
BRIDGE NO. 99/540 NB & SB

PIER 6S SHAFT DETAILS

BRIDGE SHEET NO. BG057
SHEET 903 OF 1475 SHEETS

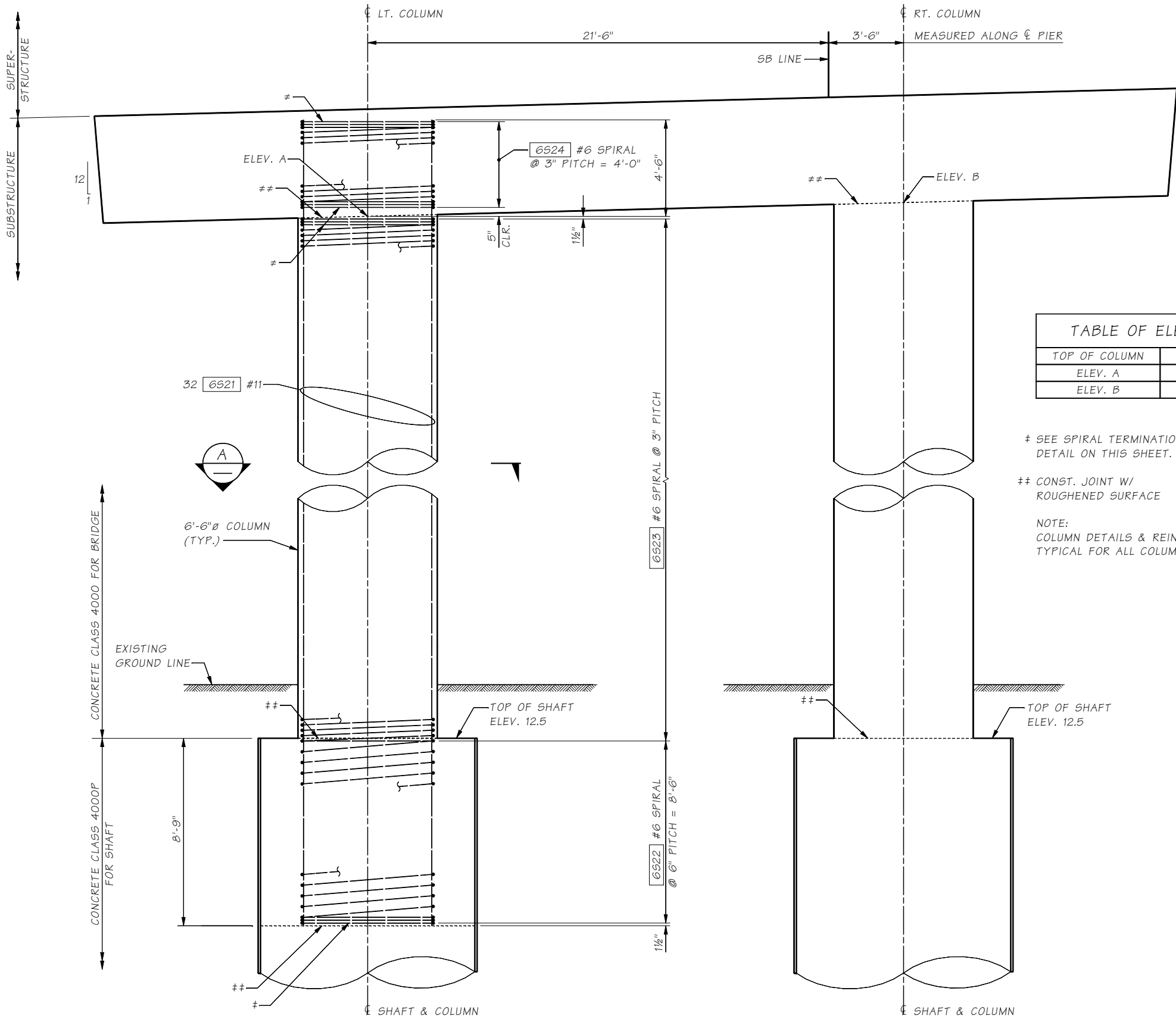

TOP OF COLUMN	ELEVATION
ELEV. A	48.59
ELEV. B	49.25

‡ SEE SPIRAL TERMINATION
DETAIL ON THIS SHEET.

‡‡ CONST. JOINT W/
ROUGHENED SURFACE

NOTE:
COLUMN DETAILS & REINFORCING
TYPICAL FOR ALL COLUMNS.

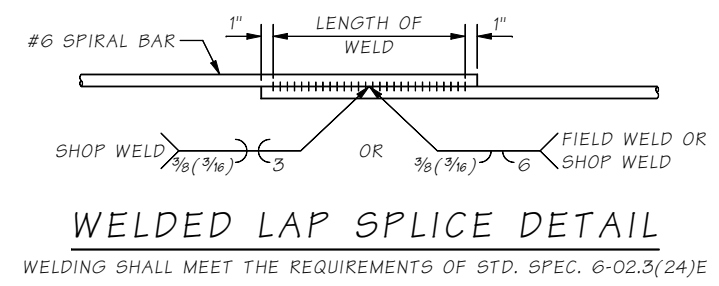
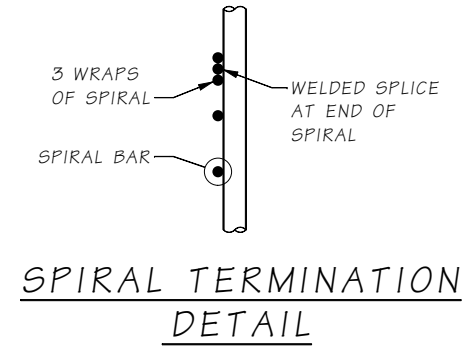
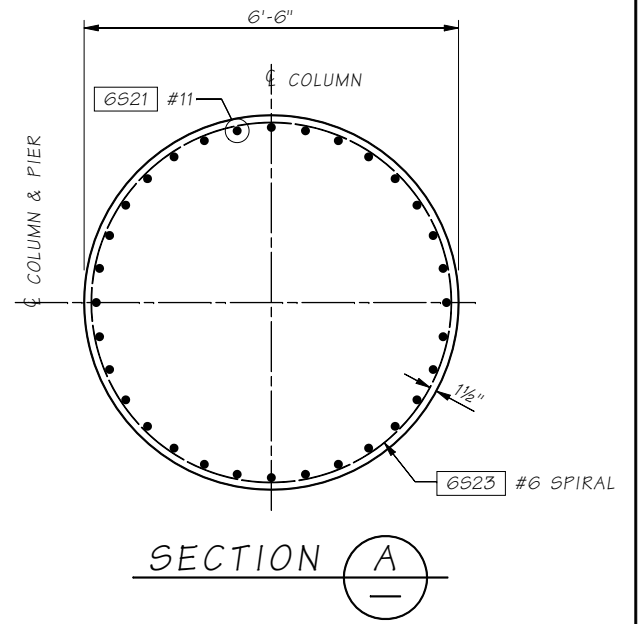

COLUMN ELEVATION - PIER 6S

SR 99 FILE NO. SHEET BG058

Bridge Design Engr. Khaleghi, B	M:\Y-Team\AWV SOUTH INTERCHANGE\window files\Pier 6S Col Dtls.WND			
Supervisor Moore, TM	REGION NO.	STATE	FED. AID PROJ. NO.	SHEET NO.
Designed By Lee, CS 10/08	10	WASH.		TOTAL SHEETS
Checked By Schultz, E 09/09	JOB NUMBER 09A803			
Detailed By Hanson, CE 10/08				
Bridge Projects Engr.	DATE	REVISION	BY	APPD
Prelim. Plan By				
Architect/Specialist				



BRIDGE AND STRUCTURES OFFICE

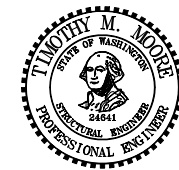

SR 99
ALASKAN WAY VIADUCT - REPLACEMENT
S HOLGATE ST TO S KING ST - PHASE 2
BRIDGE NO. 99/540 NB & SB
PIER 6S COLUMN DETAILS

BRIDGE SHEET NO. BG058
SHEET 904 OF 1475 SHEETS

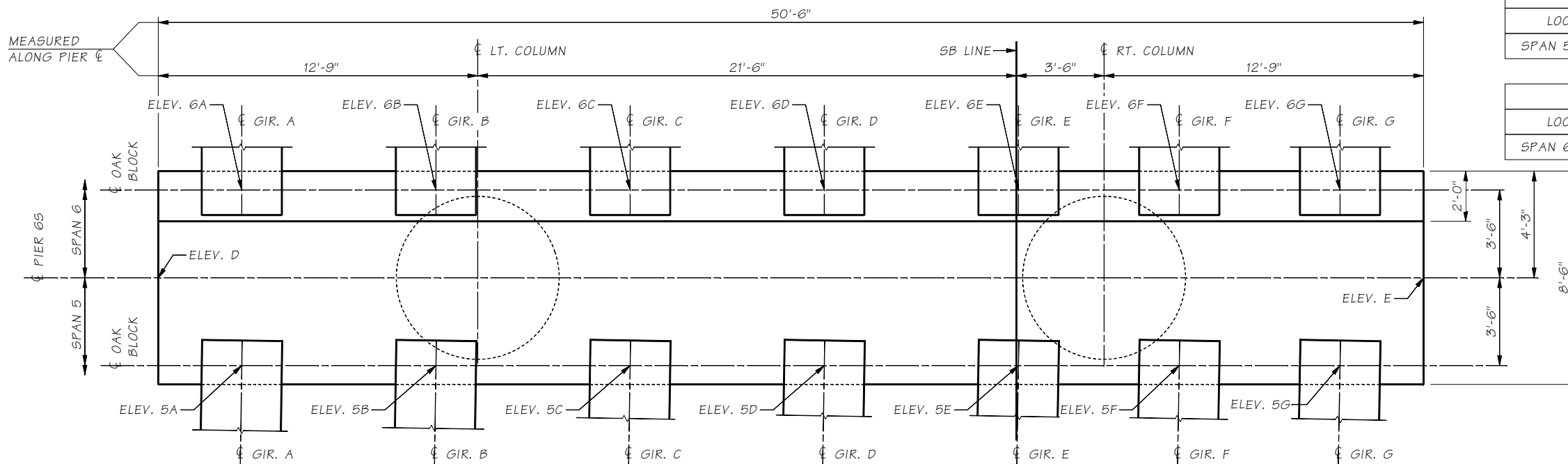

LOCATION	5A	5B	5C	5D	5E	5F	5G
SPAN 5 GIRDERS	53.59	53.80	54.00	54.21	54.41	54.58	54.75

LOCATION	6A	6B	6C	6D	6E	6F	6G
SPAN 6 GIRDERS	53.87	54.06	54.25	54.44	54.63	54.79	54.94

LOCATION	ELEVATION
D	53.25
E	54.59
F	60.74
G	62.02

NOTE:
SEE FRAMING PLAN FOR GIRDER SPACING.

PLAN

* SEE FPS SHEETS FOR EXACT LOCATION. ADJUST DIAPHRAGM REINFORCING CONFLICT WITH BLOCKOUT.

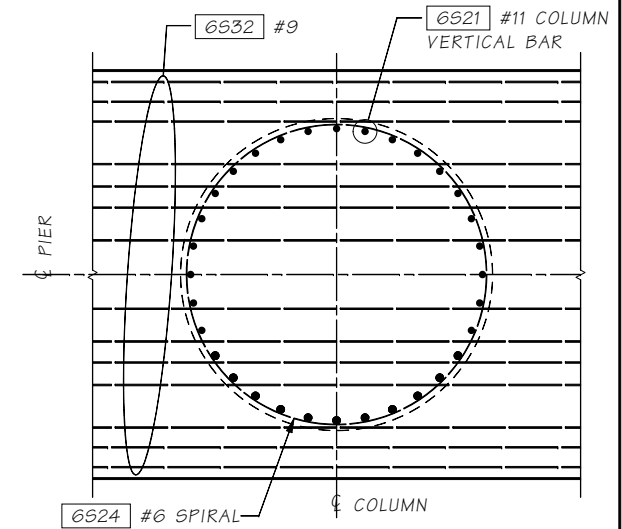
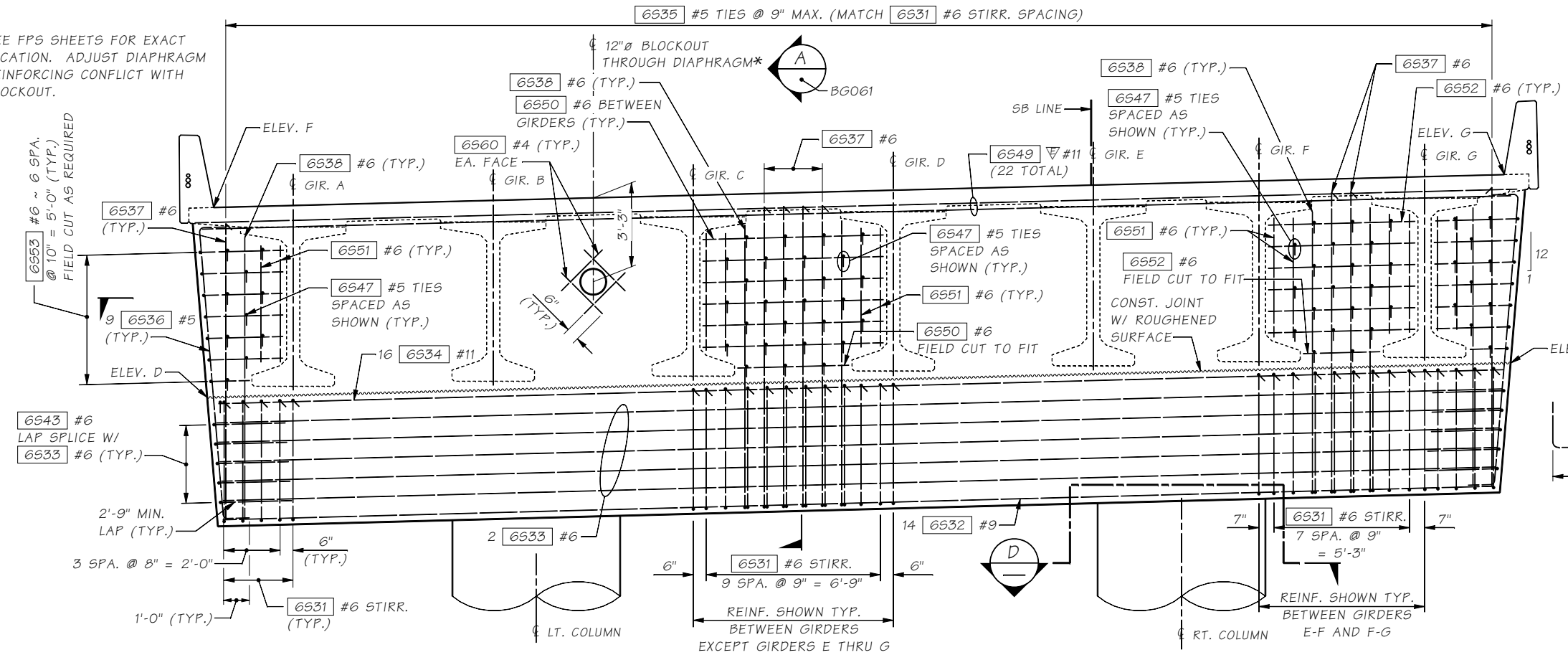

SECTION D

TRANSVERSE REINFORCING NOT SHOWN FOR CLARITY. ADJUST LONGITUDINAL BAR, TRANSVERSE STIRRUP, AND THE TIE SPACING AS REQUIRED TO CLEAR COLUMN VERTICAL BARS.

- NOTES:
1. SLAB REINFORCING NOT SHOWN FOR CLARITY.
 2. ADJUST STIRRUP AND TIE SPACING AS REQUIRED TO CLEAR COLUMN VERTICAL BARS.
 3. DIAPHRAGM REINFORCING SHOWN FOR SPAN 5 FACE ONLY. SEE SECTION B FOR DETAILS.

ELEVATION

SR 99 FILE NO. SHEET BG059

Bridge Design Engr. Khaleghi, B	M:\Y-Team\AW SOUTH INTERCHANGE\window files\Pier 6S X-Beam Plan-Elev.WND				
Supervisor Moore, TM	REGION NO.	STATE	FED. AID PROJ. NO.	SHEET NO.	TOTAL SHEETS
Designed By Lee, CS 10/08	10	WASH.			
Checked By Glassford, P 09/09	JOB NUMBER 09A803				
Detailed By Lemcke, DR 05/09					
Bridge Projects Engr.					
Prelim. Plan By					
Architect/Specialist	DATE	REVISION	BY	APPD	



BRIDGE AND STRUCTURES OFFICE

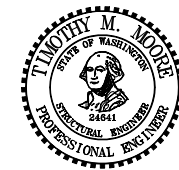

SR 99
ALASKAN WAY VIADUCT - REPLACEMENT
S HOLGATE ST TO S KING ST - PHASE 2
BRIDGE NO. 99/540 NB & SB

PIER 6S CROSSBEAM
PLAN AND ELEVATION

BRIDGE SHEET NO. BG059
SHEET 905 OF 1475 SHEETS

SR 99 FILE NO. SHEET BG060

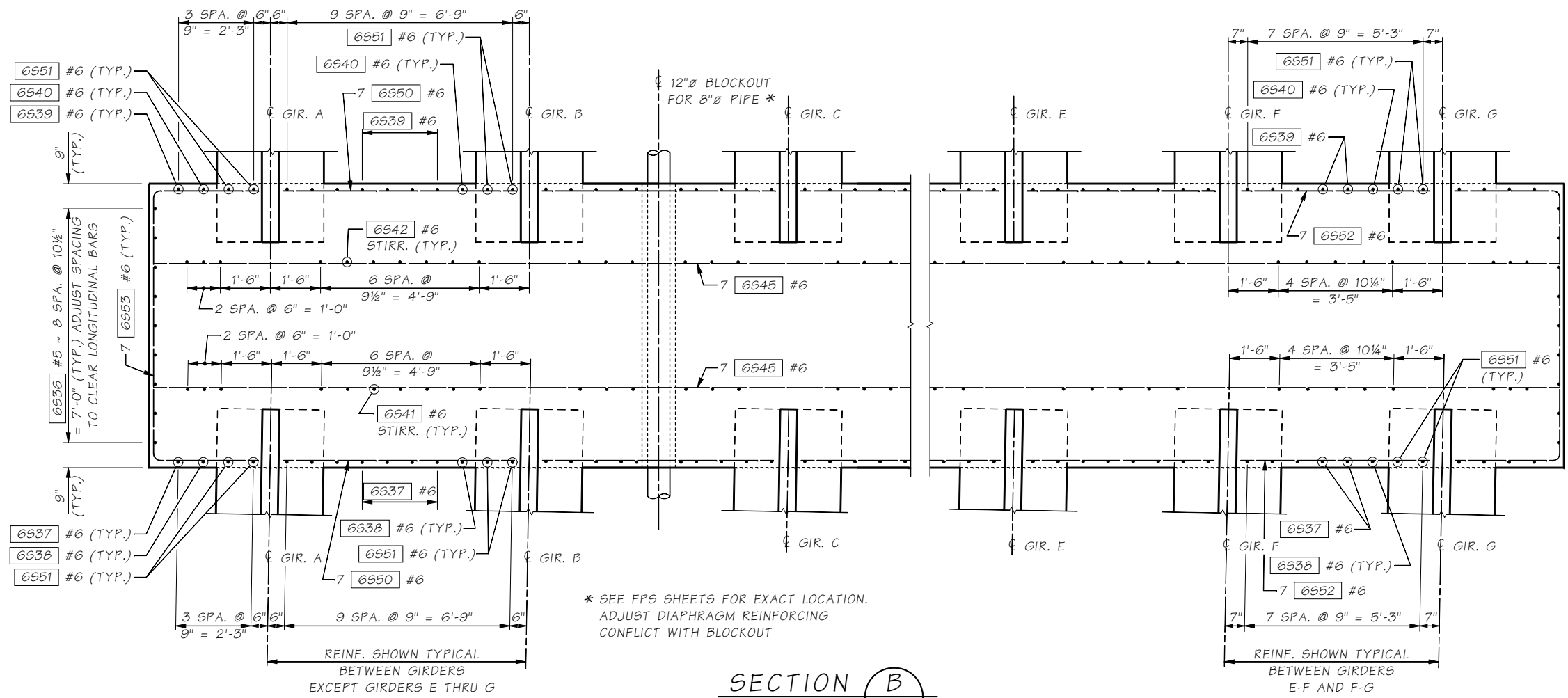

* SEE FPS SHEETS FOR EXACT LOCATION.
ADJUST DIAPHRAGM REINFORCING
CONFLICT WITH BLOCKOUT

Bridge Design Engr.	Khaleghi, B	M:\Y-Team\AWV SOUTH INTERCHANGE\window files\Pier 6S X-Beam Dtls.WND			
Supervisor	Moore, TM	REGION NO.	STATE	FED. AID PROJ. NO.	SHEET NO.
Designed By	Lee, CS	10	WASH.		TOTAL SHEETS
Checked By	Glassford, P	JOB NUMBER			
Detailed By	Lemcke, DR	09A803			
Bridge Projects Engr.		DATE	REVISION	BY	APPD
Prelim. Plan By					
Architect/Specialist					



BRIDGE AND STRUCTURES OFFICE

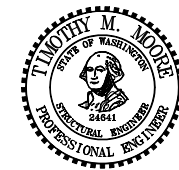

SR 99
ALASKAN WAY VIADUCT - REPLACEMENT
S HOLGATE ST TO S KING ST - PHASE 2
BRIDGE NO. 99/540 NB & SB

PIER 6S CROSSBEAM DETAILS 1 OF 2

BRIDGE SHEET NO. BG060
SHEET 906 OF 1475 SHEETS

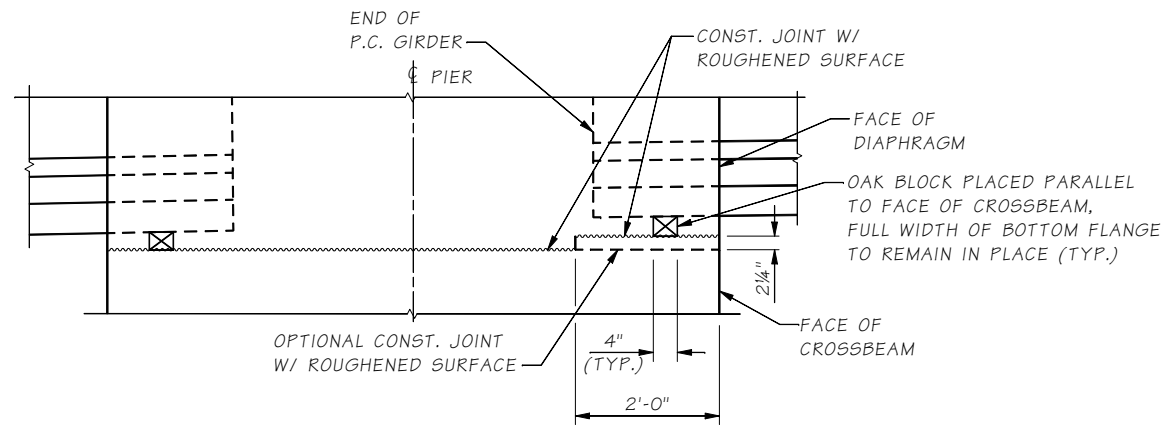

OAK BLOCK DETAIL
LONGITUDINAL DIMENSIONS ARE NORMAL TO SKEW

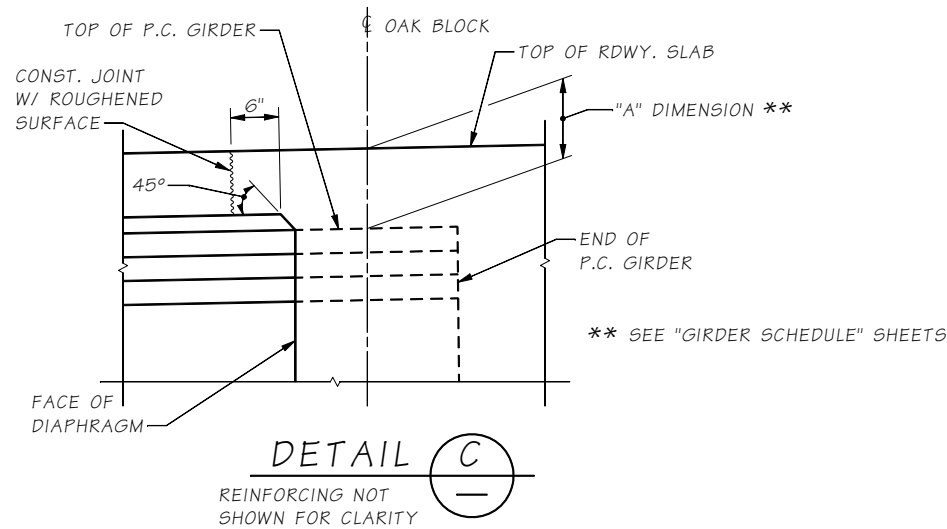

DETAIL C
REINFORCING NOT SHOWN FOR CLARITY

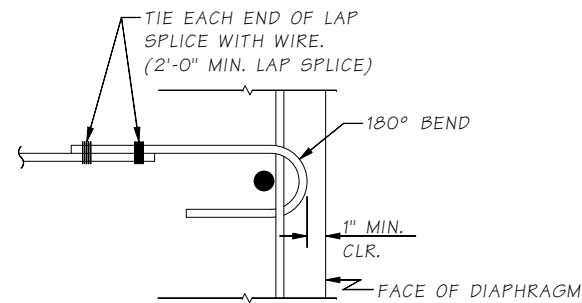

TIE BAR DETAIL

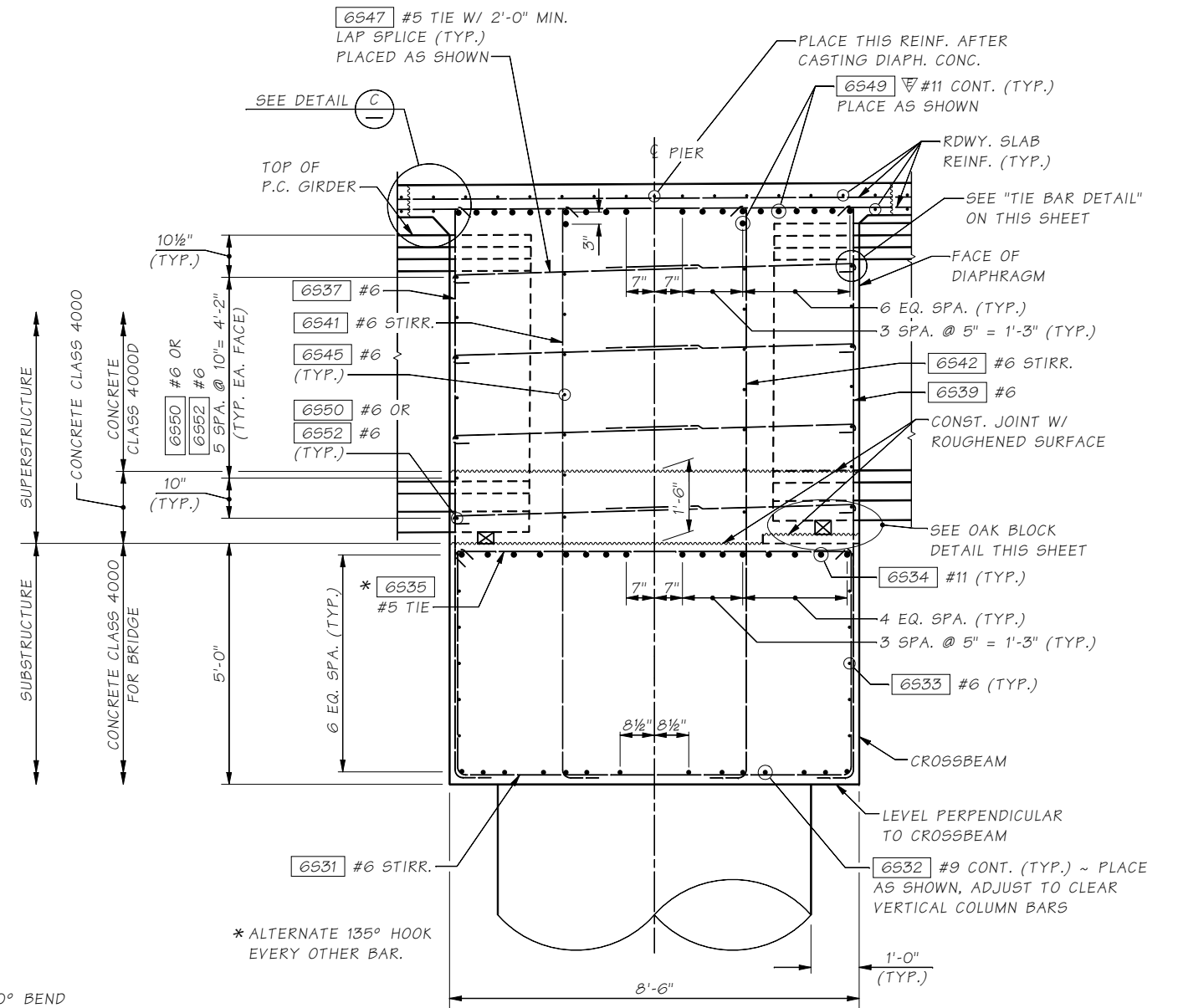

SECTION A

- NOTES:
- LONGITUDINAL DIMENSIONS ARE NORMAL TO SKEW.
 - FOR CONCRETE PLACEMENT PROCEDURE, SEE "CONSTRUCTION SEQUENCE" SHEET.

SR 99 FILE NO. SHEET BG061

Bridge Design Engr.	Khaleghi, B	M:\Y-Team\AWV SOUTH INTERCHANGE\window files\Pier 6s X-Beam Dtls 2.WND				REGION NO.	STATE	FED. AID PROJ. NO.	SHEET NO.	TOTAL SHEETS
Supervisor	Moore, TM					10	WASH.			
Designed By	Lee, CS	10/09								
Checked By	Glassford, P	09/09								
Detailed By	Lemcke, DR	05/09								
Bridge Projects Engr.						JOB NUMBER				
Prelim. Plan By						09A803				
Architect/Specialist		DATE	REVISION	BY	APPD					



BRIDGE AND STRUCTURES OFFICE



SR 99
ALASKAN WAY VIADUCT - REPLACEMENT
S HOLGATE ST TO S KING ST - PHASE 2
BRIDGE NO. 99/540 NB & SB
PIER 6S CROSSBEAM DETAILS 2 OF 2

BRIDGE SHEET NO. BG061
SHEET 907 OF 1475 SHEETS

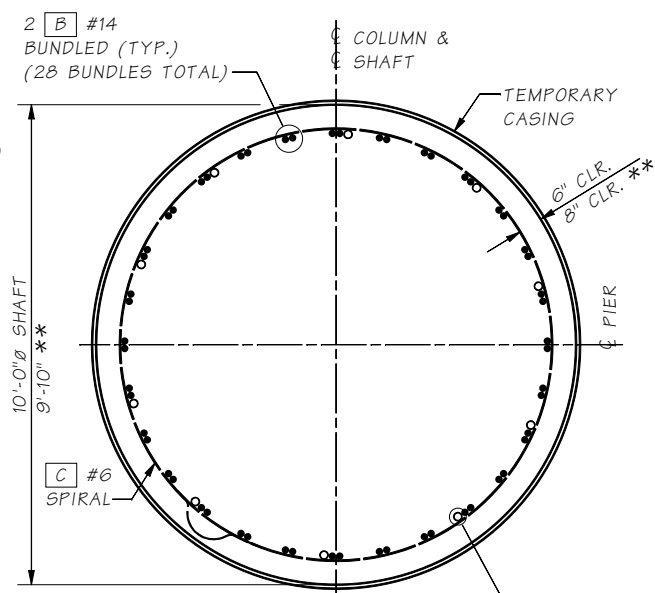
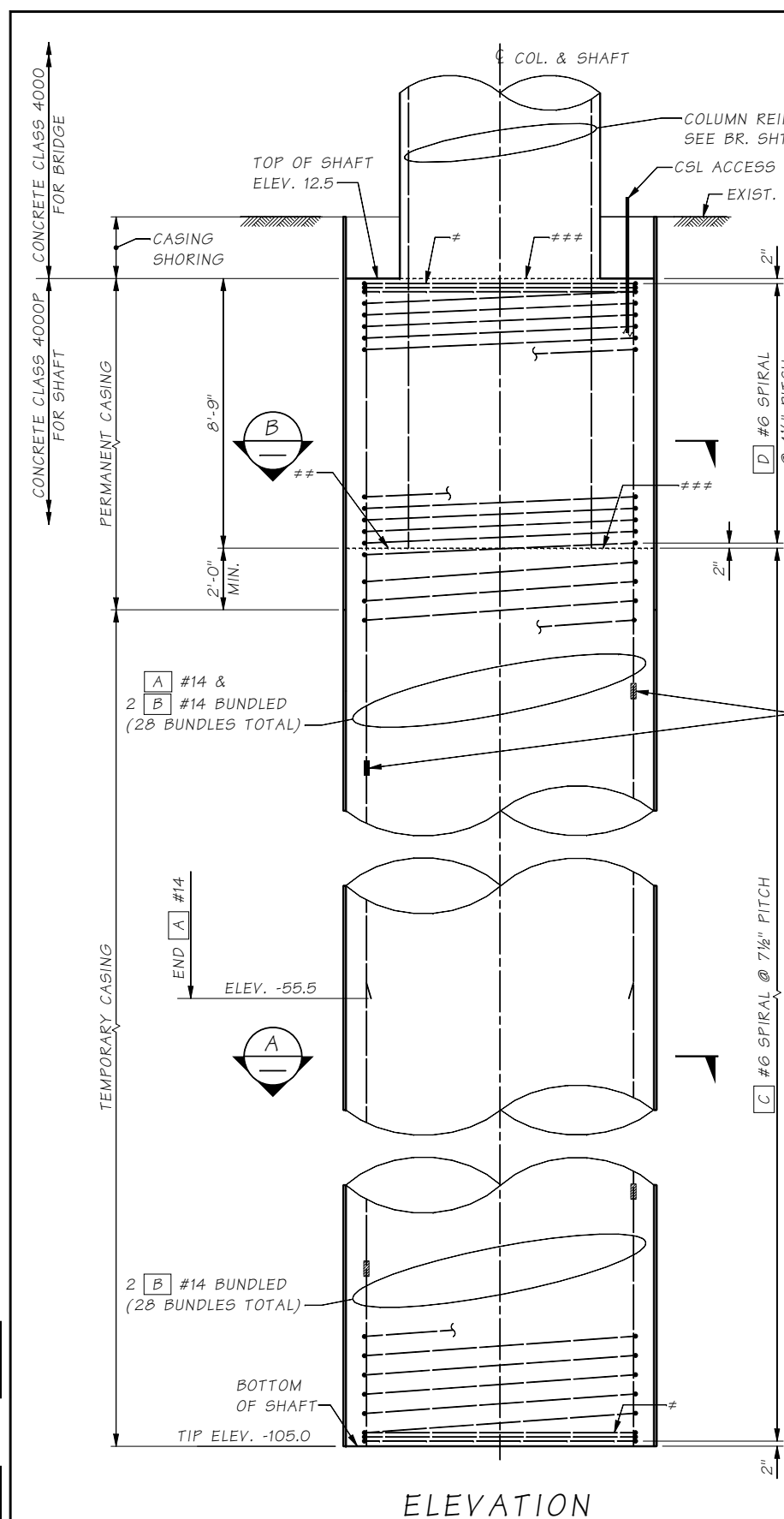

SECTION A

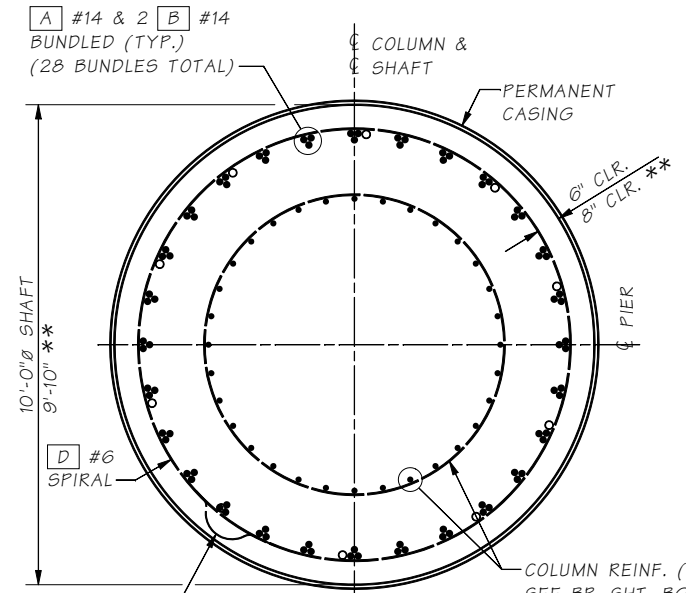

SECTION B

MECHANICAL SPLICE (TYP.) (140 TOTAL) ~ STAGGER MECHANICAL SPLICE 2'-6" VERTICALLY BETWEEN ADJACENT REBARS *

- * MECHANICAL SPLICE SHALL MEET THE REQUIREMENTS OF STD. SPEC. 6-02.3(24)F
- ** SHAFT CONSTRUCTED WITH THE OSCILLATOR METHOD. THE CONTRACTOR SHALL REVISE THE SHAFT BARLIST IF THE OSCILLATOR METHOD IS CHOSEN FOR SHAFT CONSTRUCTION
- # SEE SPIRAL TERMINATION DETAIL THIS SHEET
- ** REMOVE SEDIMENT LAITANCE & WEAK CONCRETE TO SOUND CONCRETE PRIOR TO SETTING COLUMN REINFORCEMENT
- *** CONST. JOINT WITH ROUGHENED SURFACE

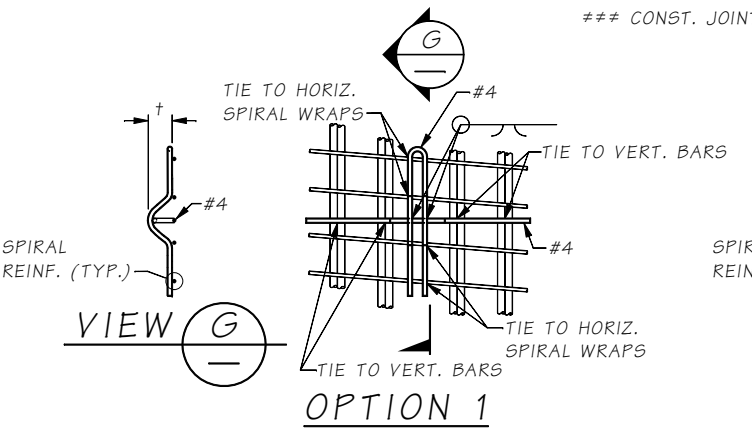

OPTION 1

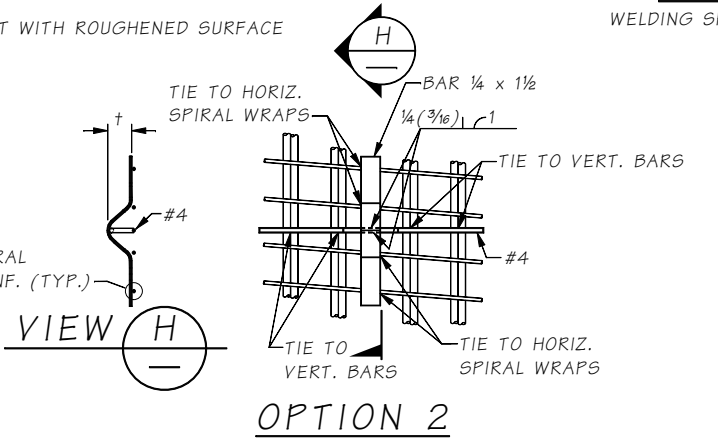

OPTION 2

CENTRALIZER DETAIL

- NOTES:
1. EPOXY COAT CENTRALIZER OR PAINT WITH INORGANIC ZINC AFTER FABRICATION.
 2. EACH LEG SHOULD BE TIED TO TWO VERTICAL BAR BUNDLES OR TWO SPIRALS.
 3. SEE SPECIAL PROVISIONS FOR SPACING REQUIREMENTS.
 4. † CONCRETE COVER MINUS 1/2"

SHAFT BAR LIST

ALL REINFORCING SHALL BE ASTM A 706 QUANTITIES ARE PER SHAFT

MARK	SIZE	NO.	LENGTH	BEND TYPE	WT. (lbs.)
A	#14	28	67'-10 1/2"	STR.	14,539
B	#14	56	117'-3"	STR.	50,230
C	#6	1	4997'-7"	67	7,506
D	#6	1	693'-10"	67	1,042
TOTAL					73,317

(a) ~ DETERMINED FROM PLANS
WEIGHT INCLUDES SPLICES
SPIRAL (BEND TYPE 67)

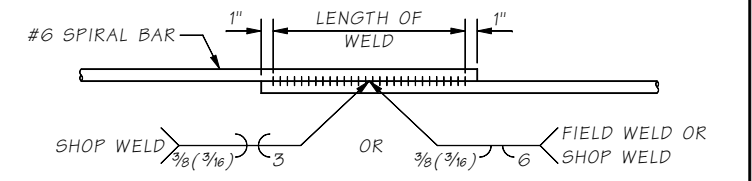

WELDED LAP SPLICE DETAIL

WELDING SHALL MEET THE REQUIREMENTS OF STD. SPEC. 6-02.3(24)E

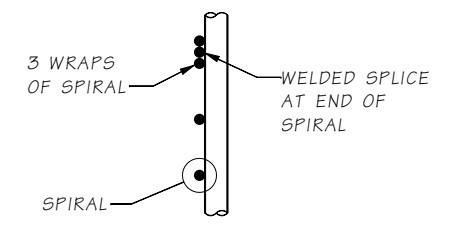

SPIRAL TERMINATION DETAIL

Bridge Design Engr. Khaleghi, B	M:\Y-Team\AWV SOUTH INTERCHANGE\window files\Pier 7s Shaft Details.WND	REGION NO.	STATE	FED. AID PROJ. NO.	SHEET NO.	TOTAL SHEETS
Supervisor Moore, TM		10	WASH.			
Designed By Lee, CS	10/08	JOB NUMBER 09A803				
Checked By Schultz, E	09/09					
Detailed By Hanson, CE	10/08					
Bridge Projects Engr.						
Prelim. Plan By						
Architect/Specialist	DATE	REVISION	BY	APPD		



BRIDGE AND STRUCTURES OFFICE



SR 99
ALASKAN WAY VIADUCT - REPLACEMENT
S HOLGATE ST TO S KING ST - PHASE 2
BRIDGE NO. 99/540 NB & SB

PIER 7S SHAFT DETAILS

BRIDGE SHEET NO. BG062
SHEET 908 OF 1475 SHEETS

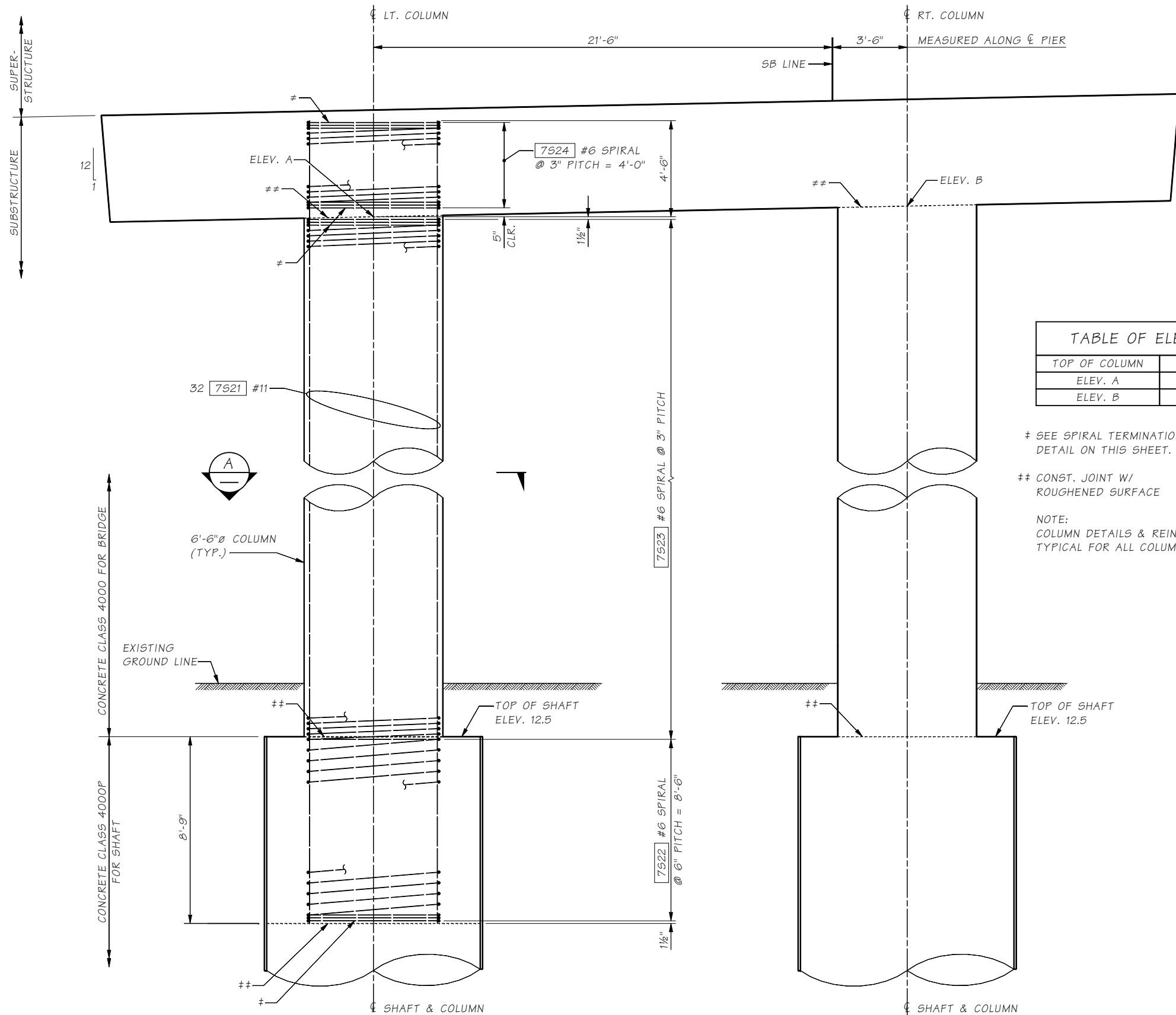
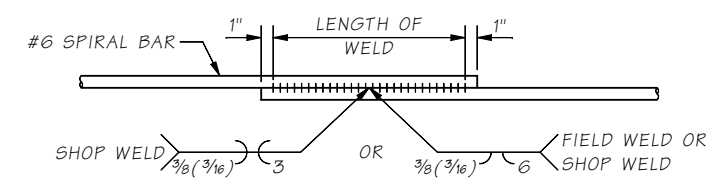
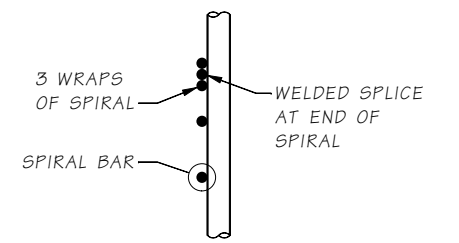
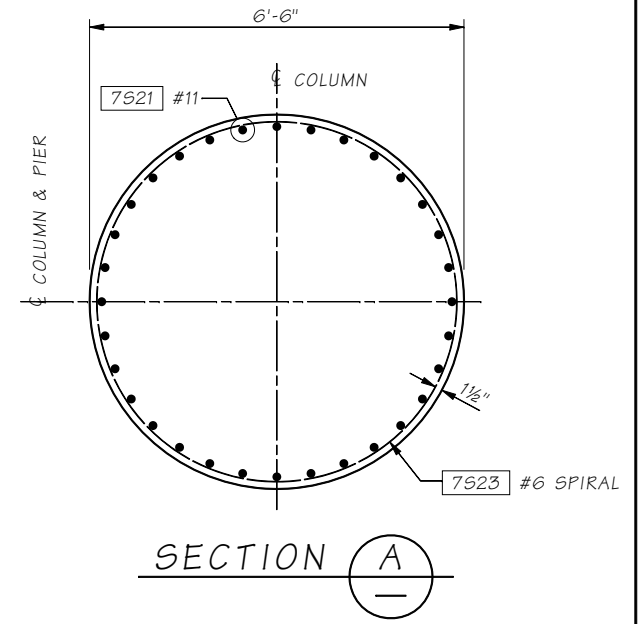

TABLE OF ELEVATIONS	
TOP OF COLUMN	ELEVATION
ELEV. A	48.91
ELEV. B	49.41

‡ SEE SPIRAL TERMINATION
DETAIL ON THIS SHEET.

CONST. JOINT W/
ROUGHENED SURFACE

NOTE:
COLUMN DETAILS & REINFORCING
TYPICAL FOR ALL COLUMNS.



WELDING SHALL MEET THE REQUIREMENTS OF STD. SPEC. 6-02.3(24)

COLUMN ELEVATION - PIER 7S

SR 99 FILE NO. SHEET BG063

Bridge Design Engr.	Khaleghi, B	M:\Y-Team\AWV SOUTH INTERCHANGE\window files\Pier 7s Col Dtl.s.wnd
Supervisor	Moore, TM	
Designed By	Lee, CS	10/08
Checked By	Schultz, E	09/09
Detailed By	Hanson, CE	10/08
Bridge Projects Engr.		
Prelim. Plan By		
Architect/Specialist		



BRIDGE AND STRUCTURES OFFICE

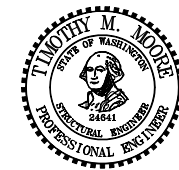

SR 99
ALASKAN WAY VIADUCT - REPLACEMENT
S HOLGATE ST TO S KING ST - PHASE 2
BRIDGE NO. 99/540 NB & SB
PIER 7S COLUMN DETAILS

BRIDGE SHEET NO. BG063
SHEET 909 OF 1475 SHEETS

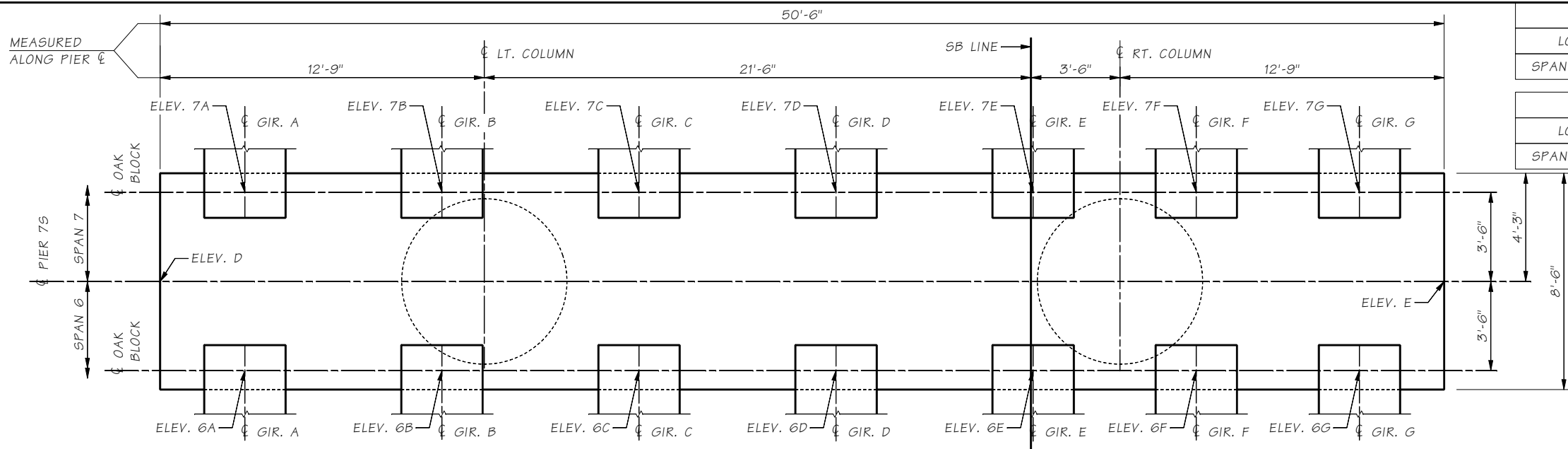

LOCATION	6A	6B	6C	6D	6E	6F	6G
SPAN 6 GIRDERS	54.02	54.18	54.33	54.49	54.64	54.77	54.90

LOCATION	7A	7B	7C	7D	7E	7F	7G
SPAN 7 GIRDERS	53.99	54.15	54.30	54.46	54.61	54.74	54.87

LOCATION	ELEVATION
D	53.66
E	54.67
F	60.95
G	61.95

NOTE:
SEE FRAMING PLAN FOR GIRDER SPACING.

PLAN

** AFTER BRIDGE STAGE 1 OPERATIONAL PHASE,
REMOVE & REPLACE NOZZLE TO EAST SIDE
AND CAP FPS SYSTEM AT FACE OF X-BM.

*** FUTURE CAP AFTER BRIDGE STAGE 1.

* FPS PIPE EMBEDDED
IN DIAPHRAGM, SEE
FPS SHEETS FOR
EXACT LOCATION.
ADJUST DIAPHRAGM
REINFORCING CONFLICT
WITH PIPES.

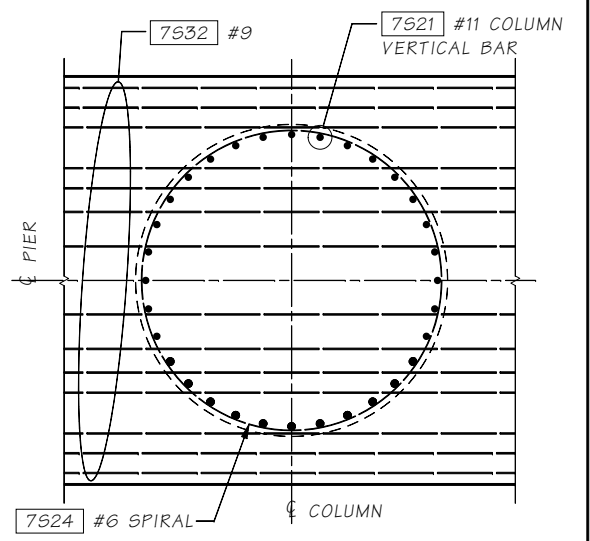
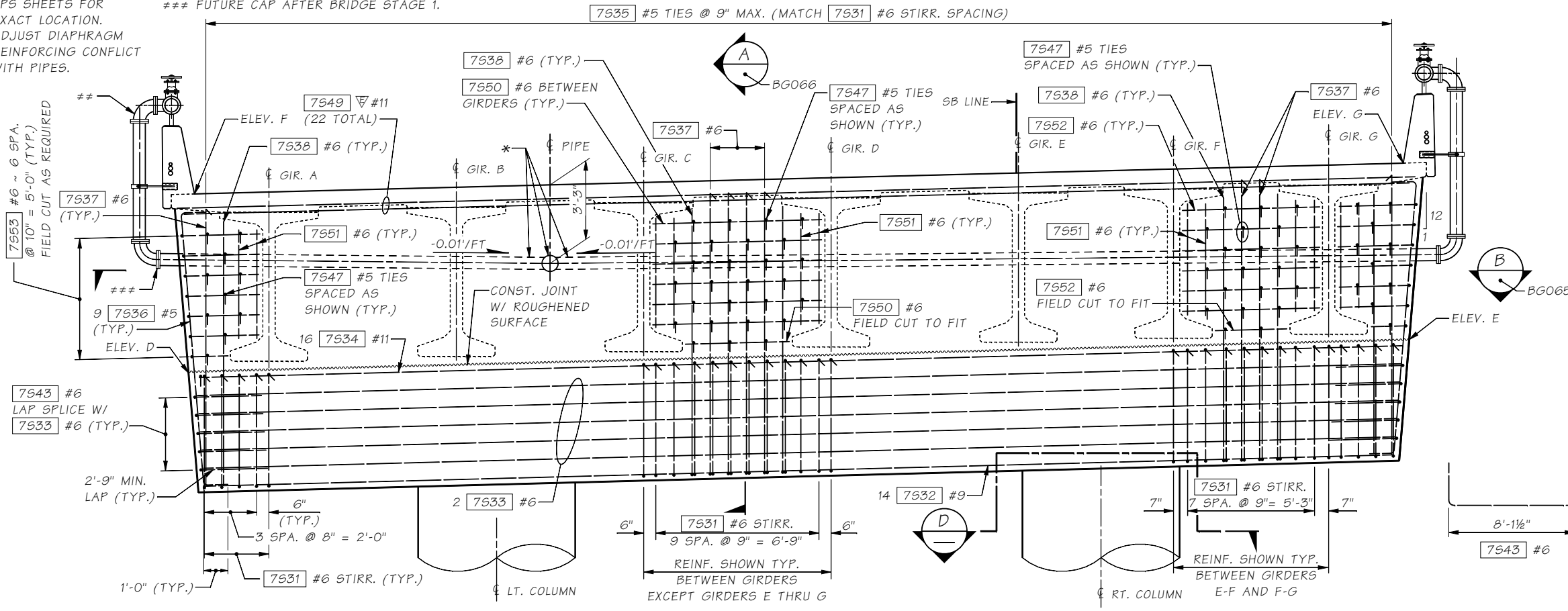

SECTION D

TRANSVERSE REINFORCING
NOT SHOWN FOR CLARITY.
ADJUST LONGITUDINAL BAR,
TRANSVERSE STIRRUP, AND THE TIE SPACING
AS REQUIRED TO CLEAR COLUMN VERTICAL BARS.

- NOTES:
1. SLAB REINFORCING NOT SHOWN FOR CLARITY.
 2. ADJUST STIRRUP AND TIE SPACING AS REQUIRED TO CLEAR COLUMN VERTICAL BARS.
 3. DIAPHRAGM REINFORCING SHOWN FOR SPAN 6 FACE ONLY. SEE SECTION B FOR DETAILS.

ELEVATION

SR 99 FILE NO. SHEET BG064

Bridge Design Engr. Khaleghi, B	M:\Y-Team\AWV SOUTH INTERCHANGE\window files\Pier 7s X-Beam Plan-Elev.WND				
Supervisor Moore, TM	REGION NO.	STATE	FED. AID PROJ. NO.	SHEET NO.	TOTAL SHEETS
Designed By Lee, CS 10/08	10	WASH.			
Checked By Glassford, P 09/09	JOB NUMBER 09A803				
Detailed By Lemcke, DR 05/09					
Bridge Projects Engr.					
Prelim. Plan By					
Architect/Specialist	DATE	REVISION	BY	APPD	



BRIDGE AND STRUCTURES OFFICE

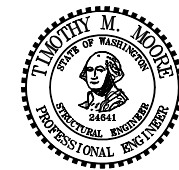

SR 99
ALASKAN WAY VIADUCT - REPLACEMENT
S HOLGATE ST TO S KING ST - PHASE 2
BRIDGE NO. 99/540 NB & SB

PIER 7S CROSSBEAM
PLAN AND ELEVATION

BRIDGE SHEET NO. BG064
SHEET 910 OF 1475 SHEETS

SR 99 FILE NO. SHEET BG065

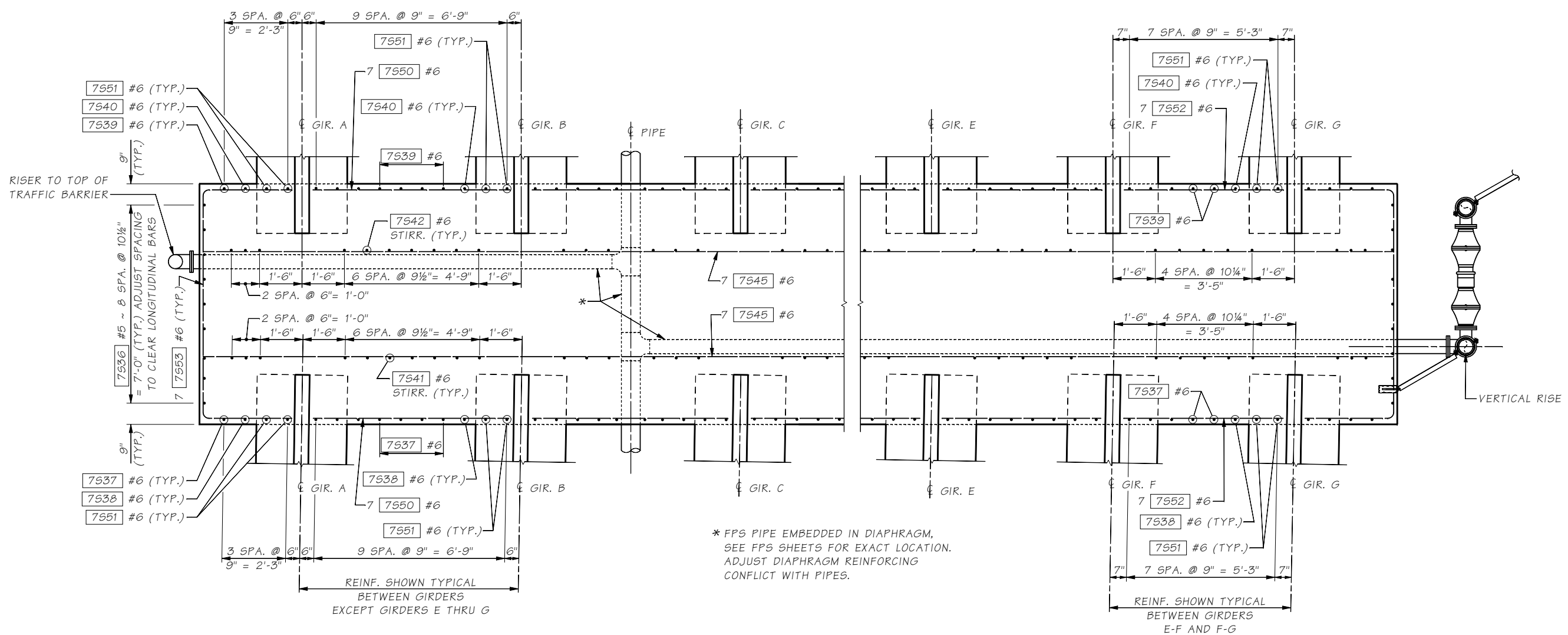

SECTION B
BG064

Bridge Design Engr.	Khaleghi, B	M:\Y-Team\AWV SOUTH INTERCHANGE\window files\Pier 7s X-Beam Dtls.WND			
Supervisor	Moore, TM	REGION NO.	STATE	FED. AID PROJ. NO.	SHEET NO.
Designed By	Lee, CS	10	WASH.		TOTAL SHEETS
Checked By	Glassford, P	JOB NUMBER			
Detailed By	Lemcke, DR	09A803			
Bridge Projects Engr.		DATE	REVISION	BY	APPD
Prelim. Plan By					
Architect/Specialist					



BRIDGE AND STRUCTURES OFFICE

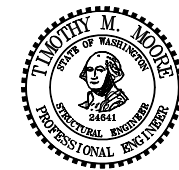

SR 99
ALASKAN WAY VIADUCT - REPLACEMENT
S HOLGATE ST TO S KING ST - PHASE 2
BRIDGE NO. 99/540 NB & SB
PIER 7S CROSSBEAM DETAILS 1 OF 2

BRIDGE SHEET NO. BG065
SHEET 911 OF 1475 SHEETS

** FPS PIPE EMBEDDED IN DIAPHRAGM, SEE FPS SHEETS FOR EXACT LOCATION. ADJUST DIAPHRAGM REINFORCING CONFLICT WITH PIPES.

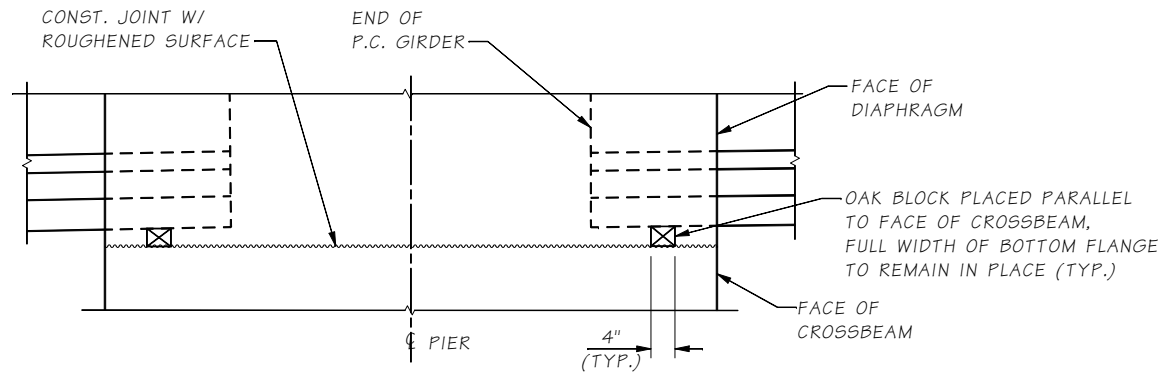

OAK BLOCK DETAIL
LONGITUDINAL DIMENSIONS ARE NORMAL TO SKEW

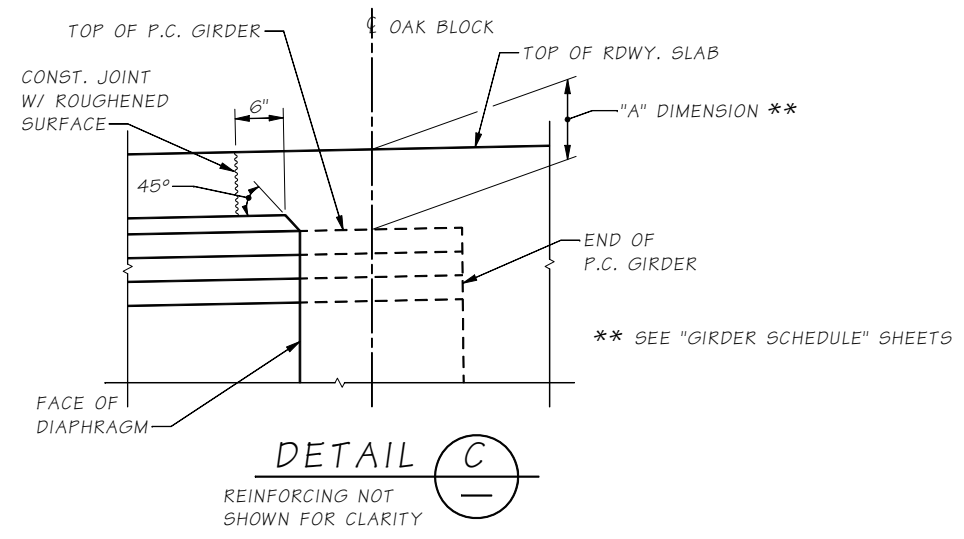

DETAIL C
REINFORCING NOT SHOWN FOR CLARITY

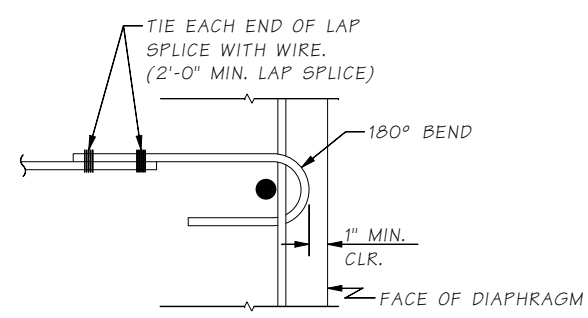

TIE BAR DETAIL

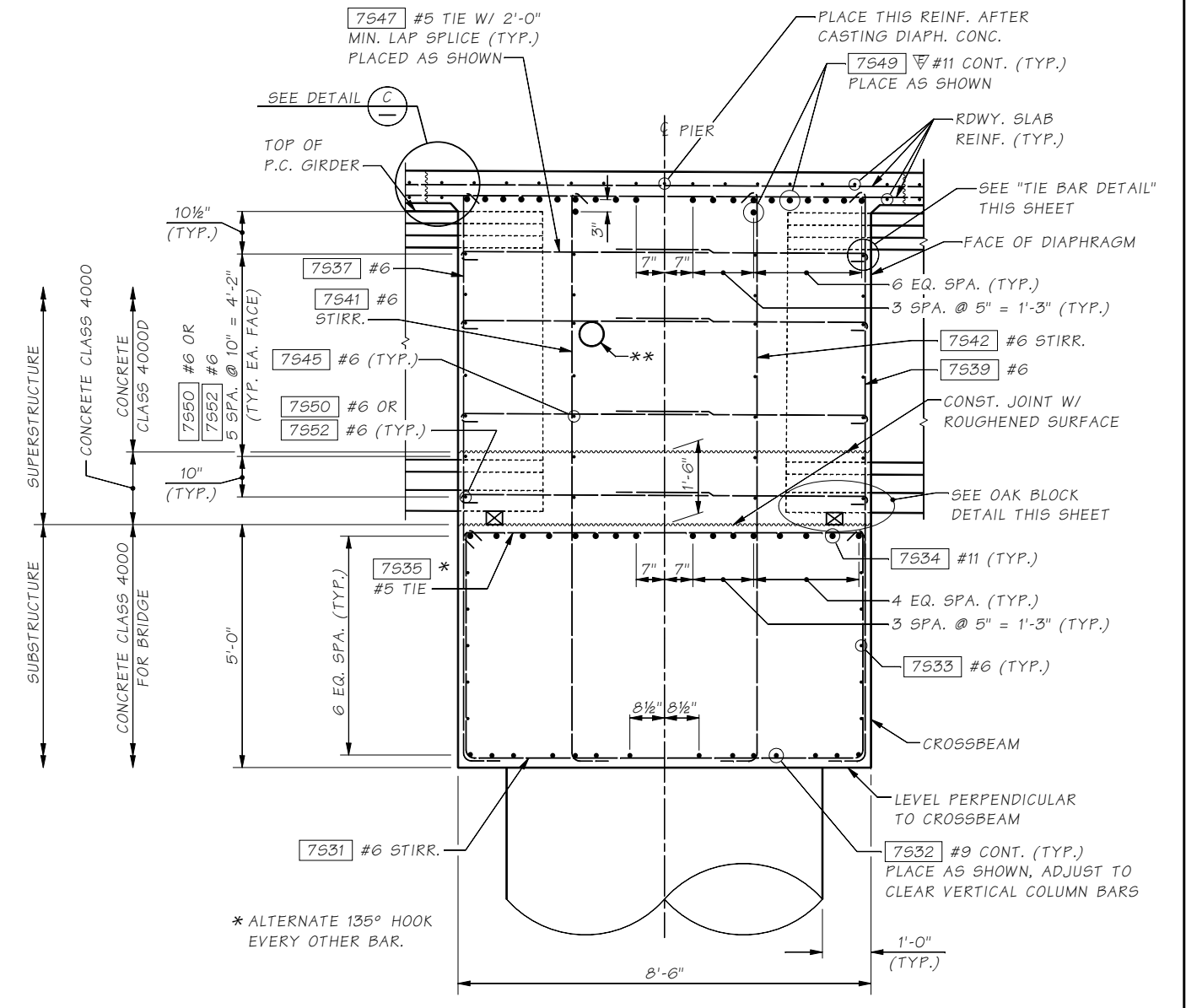

SECTION A

- NOTES:
1. LONGITUDINAL DIMENSIONS ARE NORMAL TO SKEW.
 2. FOR CONCRETE PLACEMENT PROCEDURE, SEE "CONSTRUCTION SEQUENCE" SHEET.

SR 99 FILE NO. SHEET BG066

Bridge Design Engr.	Khaleghi, B	M:\Y-Team\AWV SOUTH INTERCHANGE\window files\Pier 7s X-Beam Dtls 2.WND				REGION NO.	STATE	FED. AID PROJ. NO.	SHEET NO.	TOTAL SHEETS
Supervisor	Moore, TM									
Designed By	Lee, CS	05/09			10	WASH.				
Checked By	Glassford, P	09/09								
Detailed By	Lemcke, DR	05/09								
Bridge Projects Engr.										
Prelim. Plan By										
Architect/Specialist		DATE	REVISION	BY	APPD					



BRIDGE AND STRUCTURES OFFICE

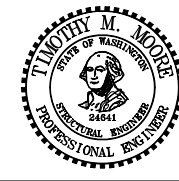

SR 99
ALASKAN WAY VIADUCT - REPLACEMENT
S HOLGATE ST TO S KING ST - PHASE 2
BRIDGE NO. 99/540 NB & SB
PIER 7S CROSSBEAM DETAILS 2 OF 2

BRIDGE SHEET NO. BG066
SHEET 912 OF 1475 SHEETS

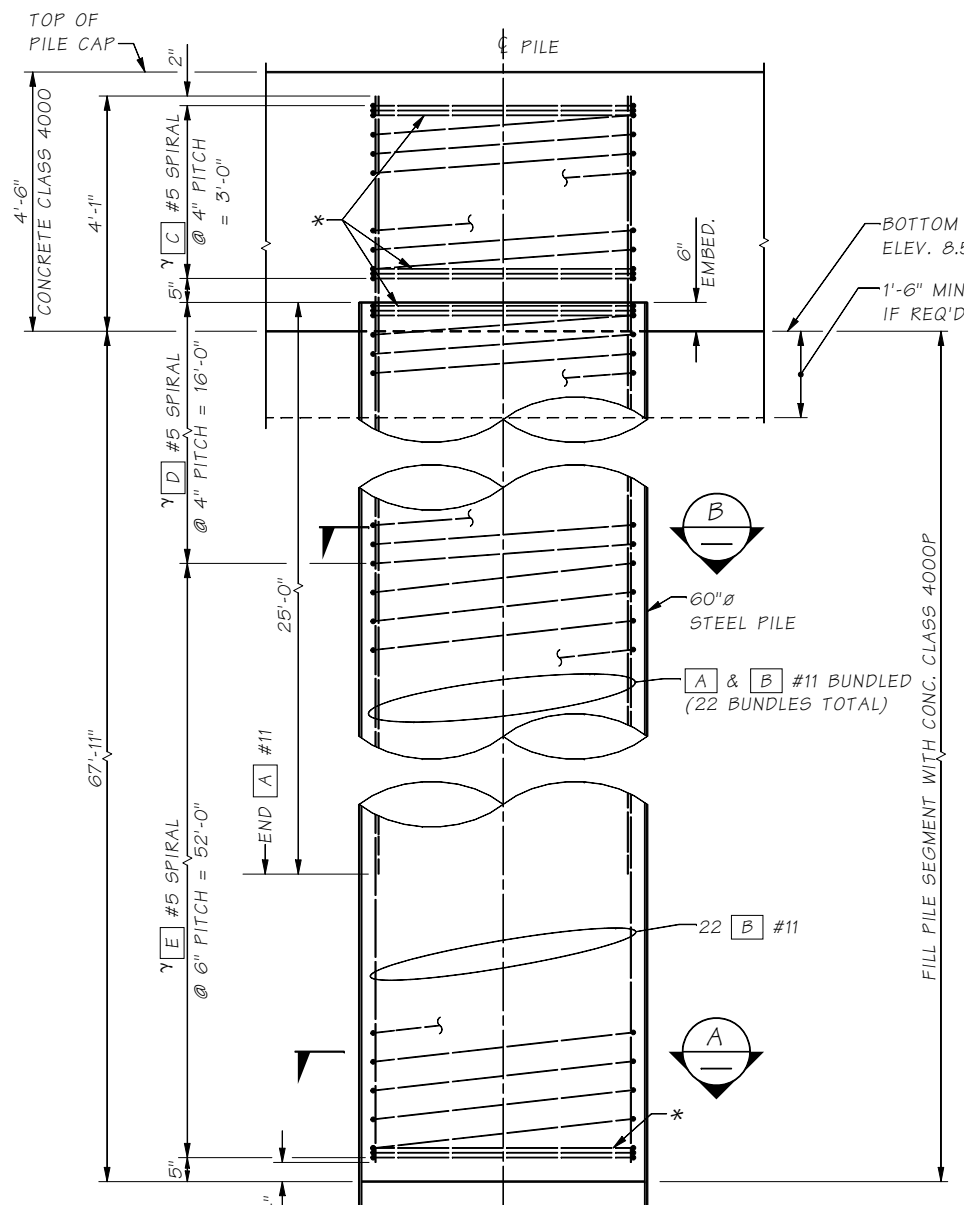

* SEE SPIRAL TERMINATION DETAIL ON THIS SHEET.

γ WELDED SPlice ONLY (SEE WELDED LAP SPlice DETAIL ON THIS SHEET)

MIN. TIP ELEVATION SEE SPECIAL PROVISIONS

OPEN END WITH CUTTING SHOE, SEE PILE TIP DETAIL ON THIS SHEET.

TYPICAL PILE ELEVATION

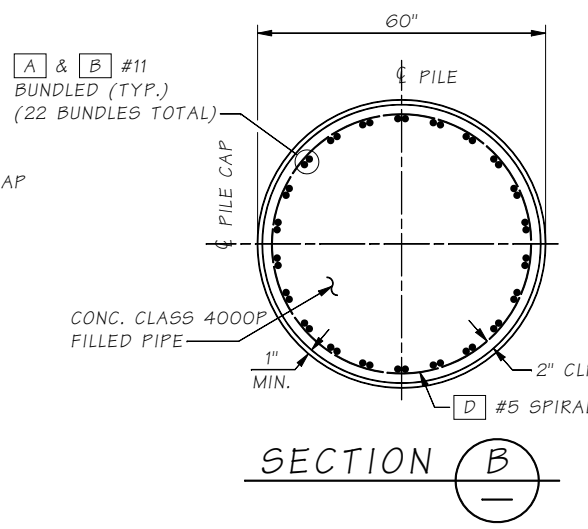

SECTION B

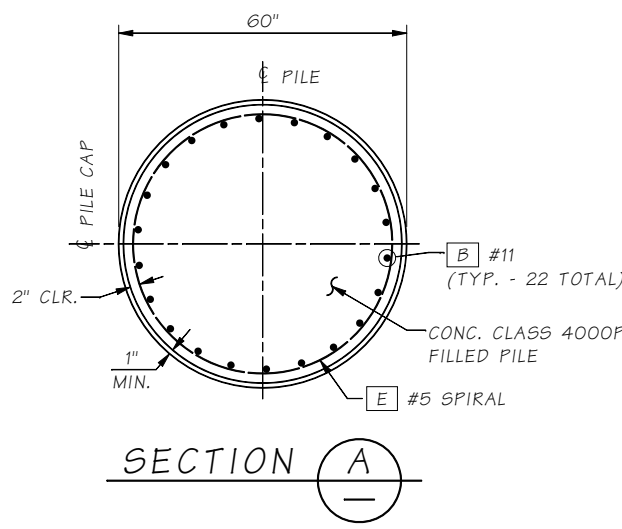

SECTION A

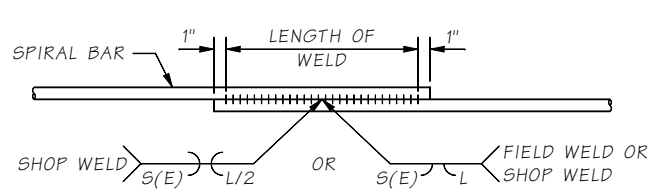

WELDED LAP SPlice DETAIL

WELDING SHALL MEET THE REQUIREMENTS OF STD. SPEC. 6-02.3(24)E FOR WELD DIMENSIONS, SEE TABLE BELOW.

DEFORMED BAR	WELD DIMENSIONS		
	S	E	LENGTH (L)
#5	3/16	3/16	6"

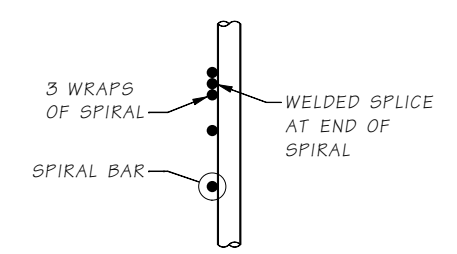

SPIRAL TERMINATION DETAIL

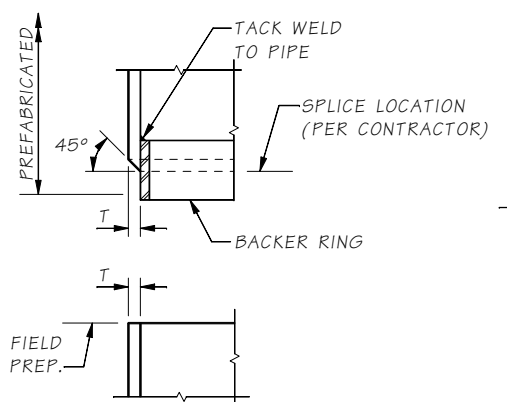

DETAIL W

PERMISSIBLE WELD SPlice DETAILS FOR STEEL PIPE PILES SEE "100% U.T. INSPECTION LIMITS" ON THIS SHEET FOR WELDING INSPECTION REQUIREMENTS.

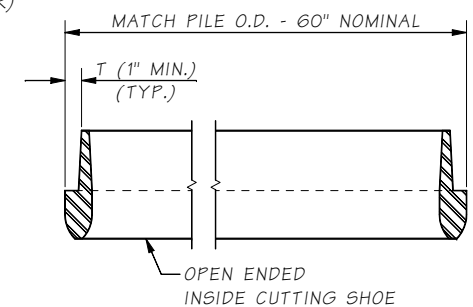

PILE TIP DETAIL

STEEL PILE WALL THICKNESS (T) AND CUTTING SHOE THICKNESS SHALL BE DETERMINED BY CONTRACTOR. SEE STD. SPEC. 6-05.3(B)

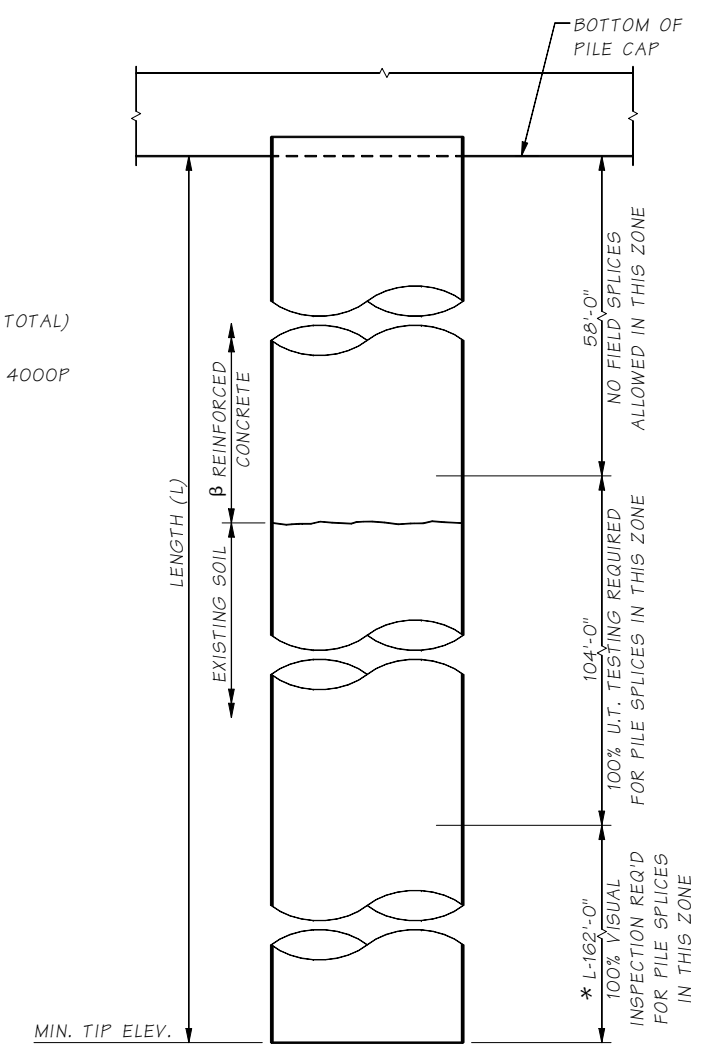

100% U.T. INSPECTION LIMITS

* ALL FIELD SPlices FOR TEST PILE REQUIRE 100% U.T. TESTING
 β SEE PILE SHEETS FOR REINFORCING DETAILS

PILE BAR LIST							
ALL REINFORCING SHALL BE ASTM A 706							
PIER	PILES REQUIRED PER PIER	MARK	BAR SIZE	BARS PER PILE	LENGTH	BEND TYPE	WT. (LBS.) PER PILE
1N	4	A	#11	22	29'-1"	STRAIGHT	3,400
		B	#11	22	71'-8"	STRAIGHT	8,377
		C	#5	1	(a)	SPIRAL	195
		D	#5	1	(a)	SPIRAL	751
		E	#5	1	(a)	SPIRAL	1592
						TOTAL	14,315

(a) ~ DETERMINED FROM PLANS

SPIRAL
WEIGHT DOES NOT INCLUDE SPlices.

SR 99 FILE NO. SHEET BG067

Bridge Design Engr. Khaleghi, B	M:\Y-Team\AWV SOUTH INTERCHANGE\window files\Pier 1N Pile Dtls.WND			
Supervisor Moore, TM	REGION NO.	STATE	FED. AID PROJ. NO.	SHEET NO.
Designed By Schultz, E 09/09	10	WASH.		
Checked By Lee, CS 09/09	JOB NUMBER 09A803			
Detailed By Hanson, CE 09/09				
Bridge Projects Engr.	DATE	REVISION	BY	APPD
Prelim. Plan By	2/17/10	REVISED SHEET	EHS	TMM
Architect/Specialist				



BRIDGE AND STRUCTURES OFFICE



SR 99
 ALASKAN WAY VIADUCT - REPLACEMENT
 S HOLGATE ST TO S KING ST - PHASE 2
 BRIDGE NO. 99/540 NB & SB
 PIER 1N PILE DETAILS

BRIDGE SHEET NO. BG067
 SHEET 913 OF 1475 SHEETS

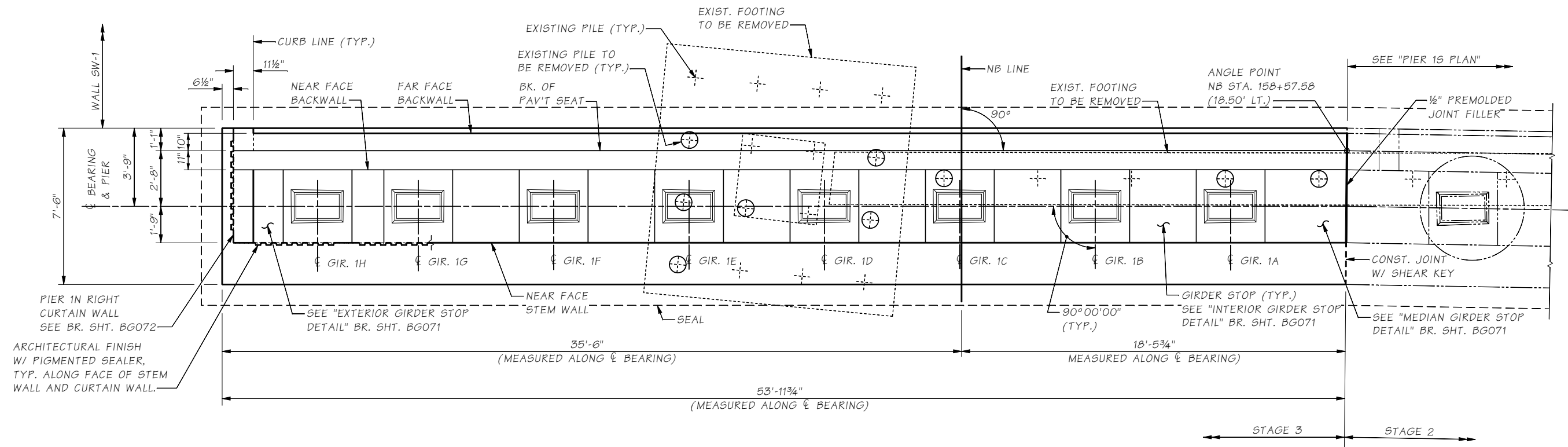

PLAN - PIER 1N
LOOKING BACK ON STATIONING

NOTE:
SEE FRAMING PLAN FOR GIRDER SPACING.

Bridge Design Engr.	Khaleghi, B	M:\Y-Team\AWV SOUTH INTERCHANGE\window files\Pier 1N Plan.WND			
Supervisor	Moore, TM	REGION NO.	STATE	FED. AID PROJ. NO.	SHEET NO.
Designed By	Schultz, E	10	WASH.		TOTAL SHEETS
Checked By	Lee, CS	JOB NUMBER 09A803			
Detailed By	Hanson, CE				
Bridge Projects Engr.					
Prelim. Plan By					
Architect/Specialist		DATE	REVISION	BY	APPD



BRIDGE AND STRUCTURES OFFICE

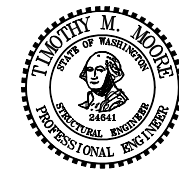

SR 99
ALASKAN WAY VIADUCT - REPLACEMENT
S HOLGATE ST TO S KING ST - PHASE 2
BRIDGE NO. 99/540 NB & SB

PIER 1N PLAN

BRIDGE SHEET NO. BG068
SHEET 914 OF 1475 SHEETS

TOP OF GROUT PAD ELEVATIONS								
GIRDER	1A	1B	1C	1D	1E	1F	1G	1H
ELEVATION	32.97	32.84	32.71	32.58	32.45	32.32	32.19	32.09

NOTE: ALL ELEVATIONS ARE AT CENTERLINE BEARING, EXCEPT THOSE MARKED WITH AN ASTERISK (*) WHICH ARE AT BACK OF PAVEMENT SEAT.

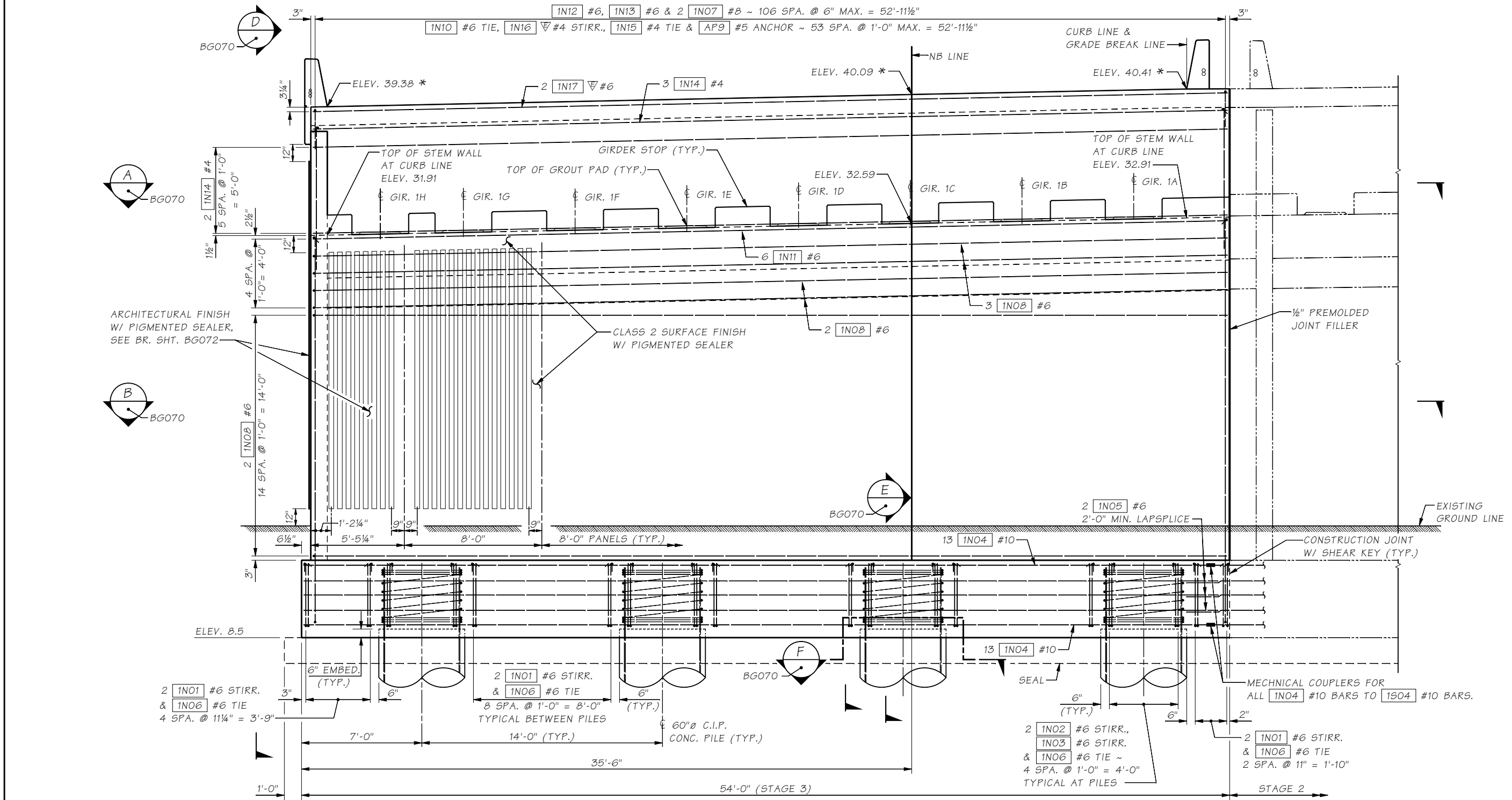

ELEVATION - PIER 1N

LOOKING BACK ON STATIONING
(CURTAIN WALL REINF. NOT SHOWN)

SR 99 FILE NO. SHEET BG069

Bridge Design Engr.	Khaleghi, B	M:\Y-Team\AWV SOUTH INTERCHANGE\window files\Pier 1N Elevation.WND			
Supervisor	Moore, TM	REGION NO.	STATE	FED. AID PROJ. NO.	SHEET NO.
Designed By	Schultz, E 09/09	10	WASH.		
Checked By	Lee, CS 09/09	JOB NUMBER	09A803		
Detailed By	Hanson, CE 09/09	DATE	REVISION	BY	APPD
Bridge Projects Engr.					
Prelim. Plan By					
Architect/Specialist					



BRIDGE AND STRUCTURES OFFICE



SR 99
ALASKAN WAY VIADUCT - REPLACEMENT
S HOLGATE ST TO S KING ST - PHASE 2
BRIDGE NO. 99/540 NB & SB
PIER 1N ELEVATION

BRIDGE SHEET NO. BG069
SHEET 915 OF 1475 SHEETS

SR 99 FILE NO. SHEET BG070

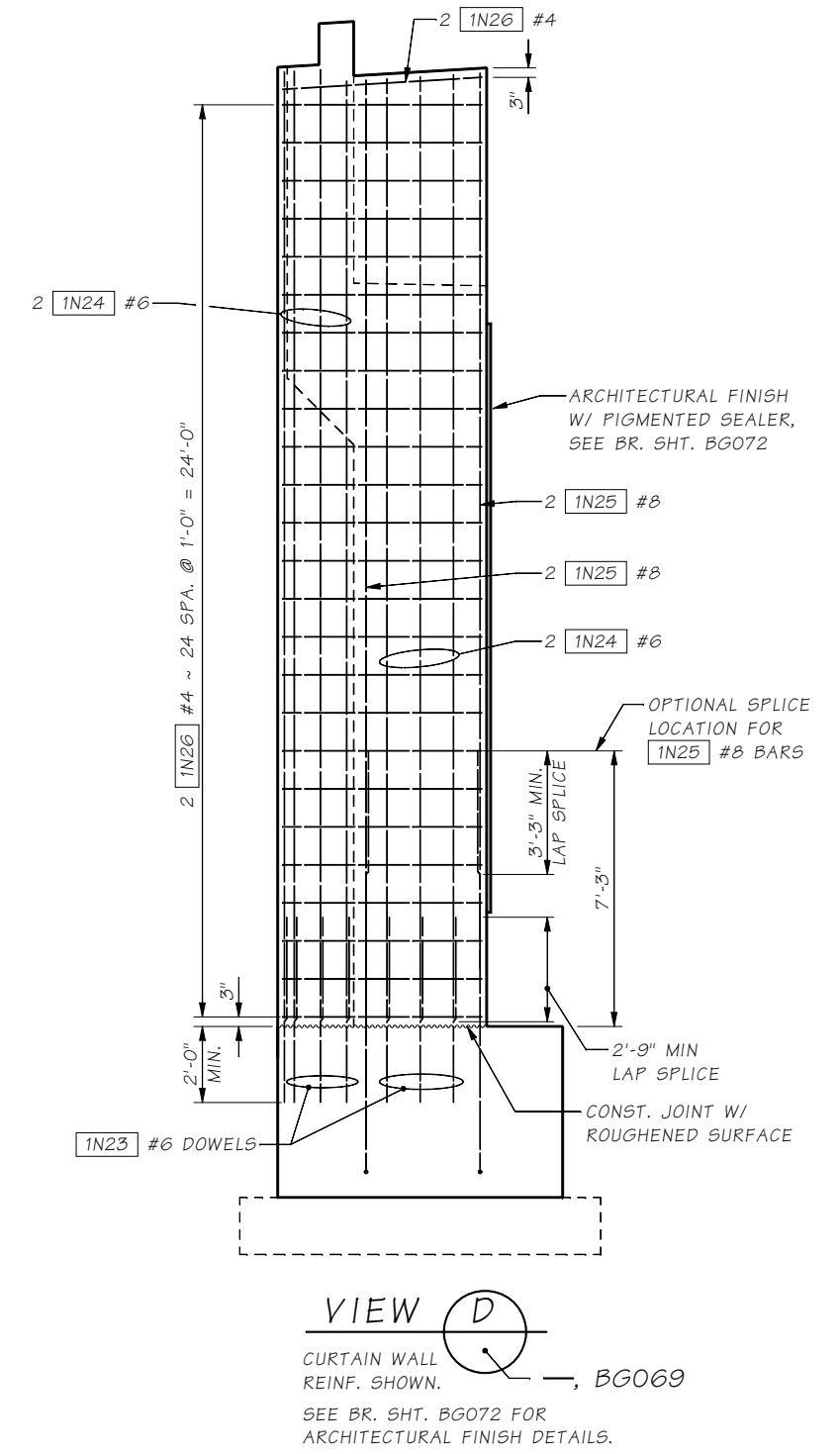
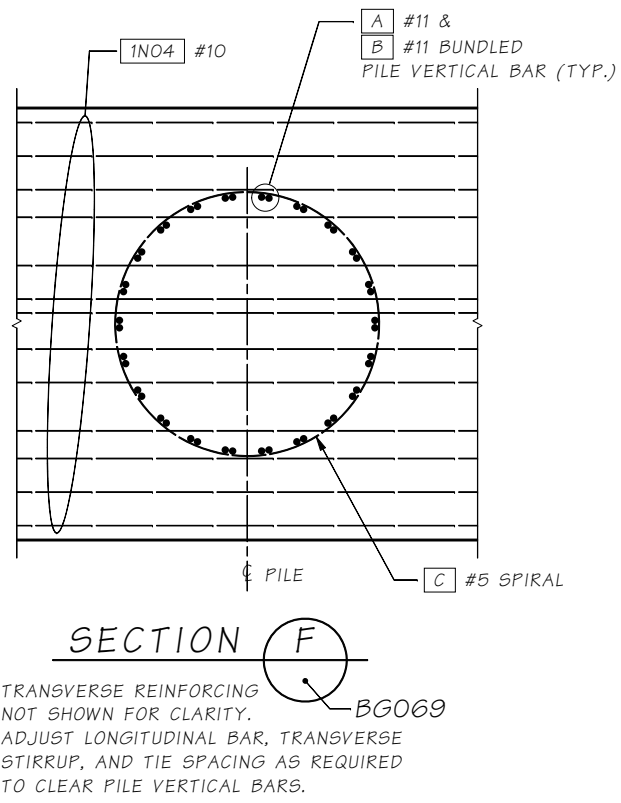
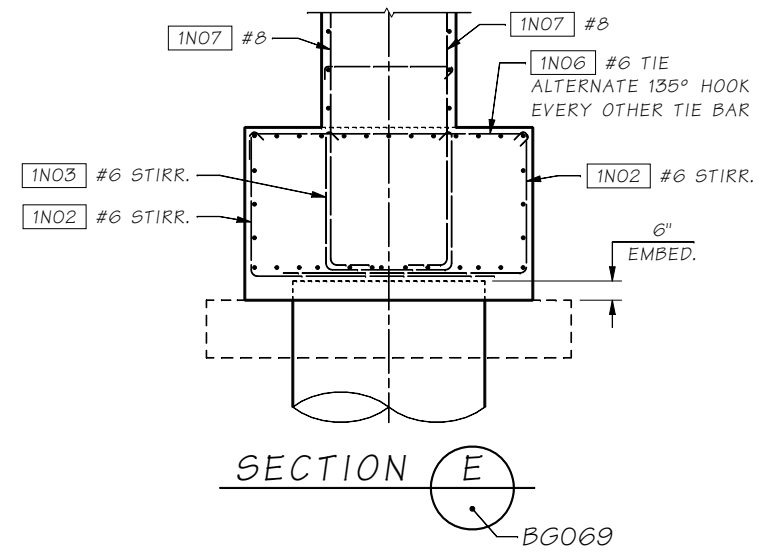
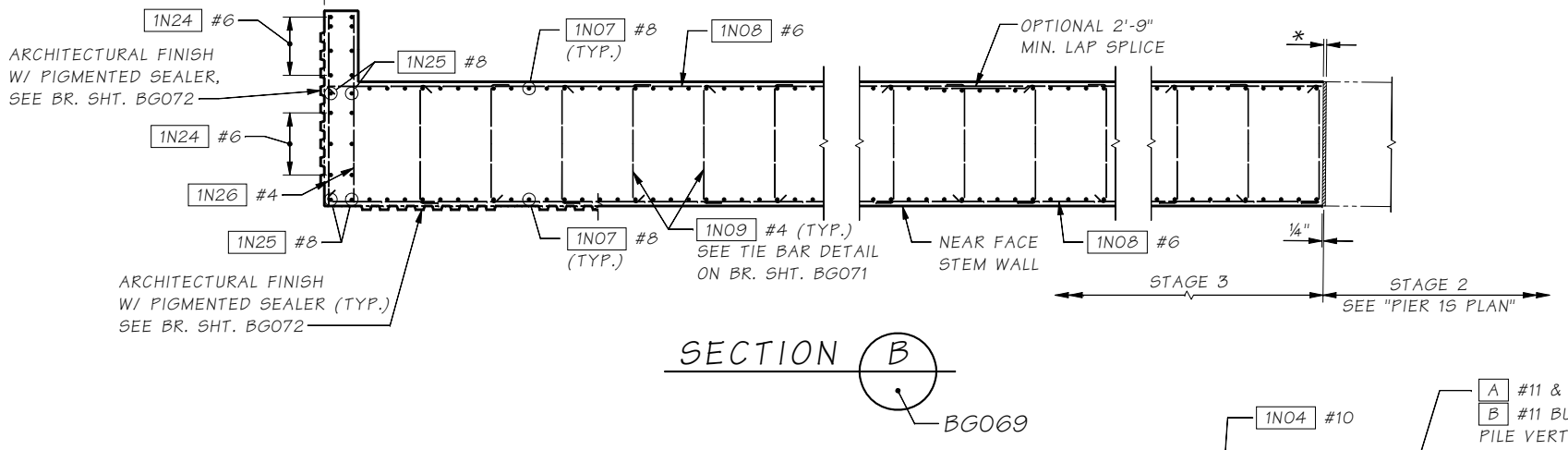
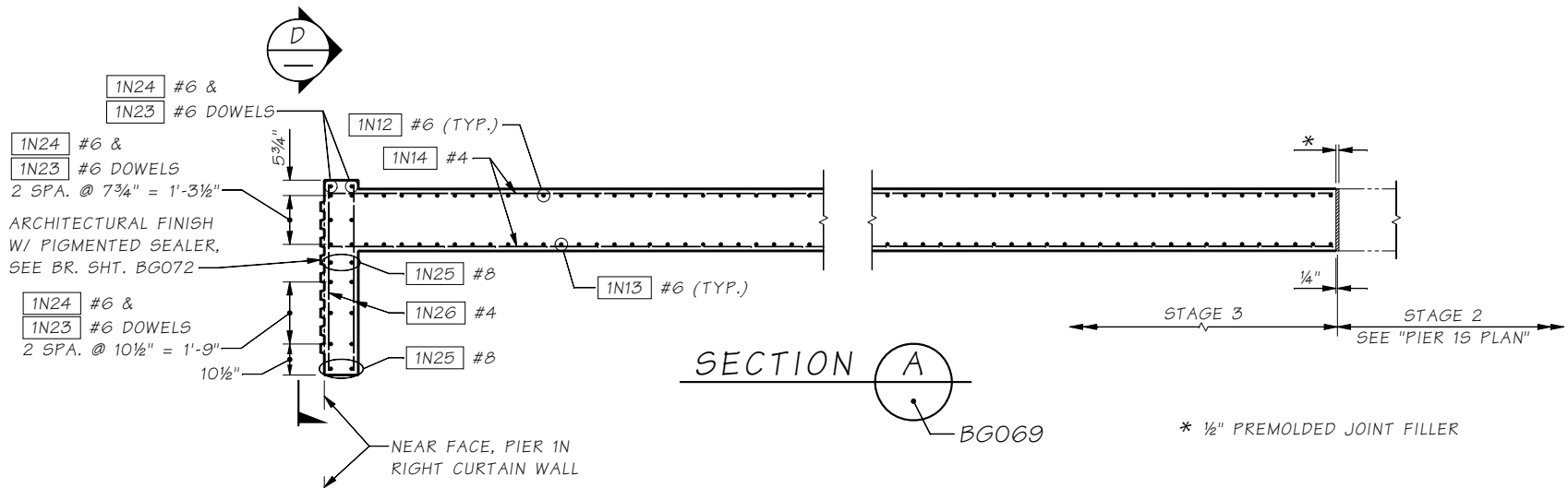

Bridge Design Engr.	Khaleghi, B	M:\Y-Team\AWW SOUTH INTERCHANGE\window files\Pier 1N Section.WND			
Supervisor	Moore, TM	REGION NO.	STATE	FED. AID PROJ. NO.	SHEET NO.
Designed By	Schultz, E 09/09	10	WASH.		TOTAL SHEETS
Checked By	Lee, CS 09/09	JOB NUMBER			
Detailed By	Hanson, CE 09/09	09A803			
Bridge Projects Engr.		DATE	REVISION	BY	APPD
Prelim. Plan By					
Architect/Specialist					



BRIDGE AND STRUCTURES OFFICE

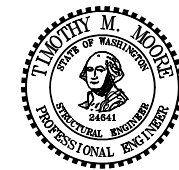

SR 99
ALASKAN WAY VIADUCT - REPLACEMENT
S HOLGATE ST TO S KING ST - PHASE 2
BRIDGE NO. 99/540 NB & SB
PIER 1N SECTION

BRIDGE SHEET NO. BG070
SHEET 916 OF 1475 SHEETS

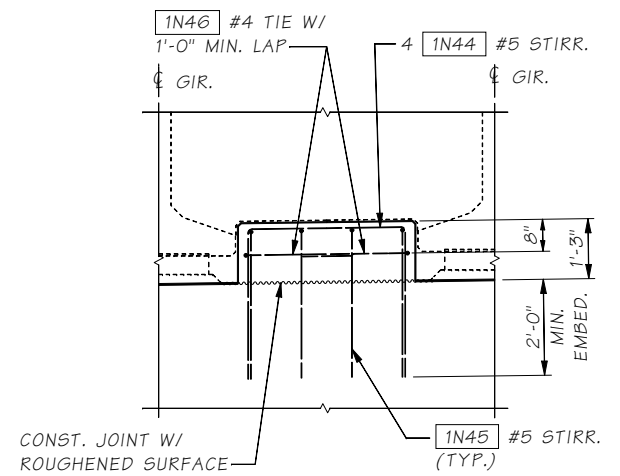
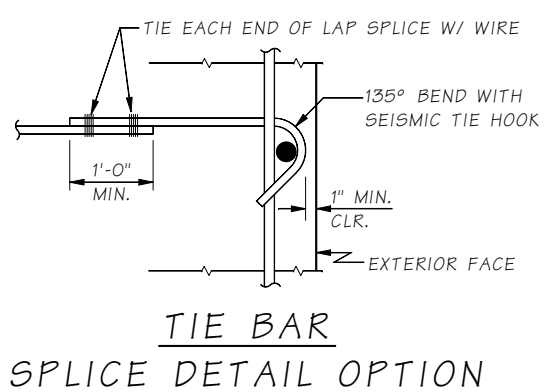
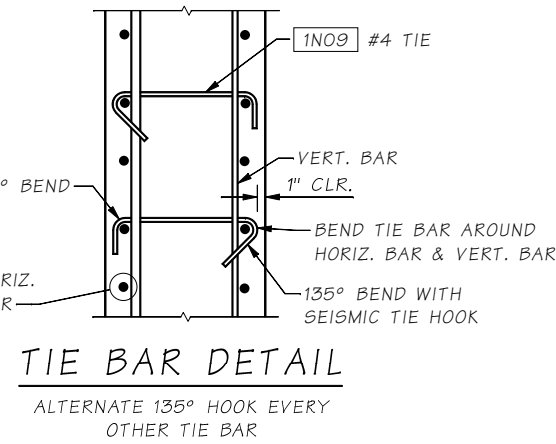
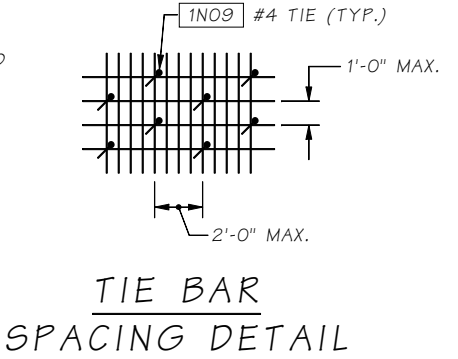
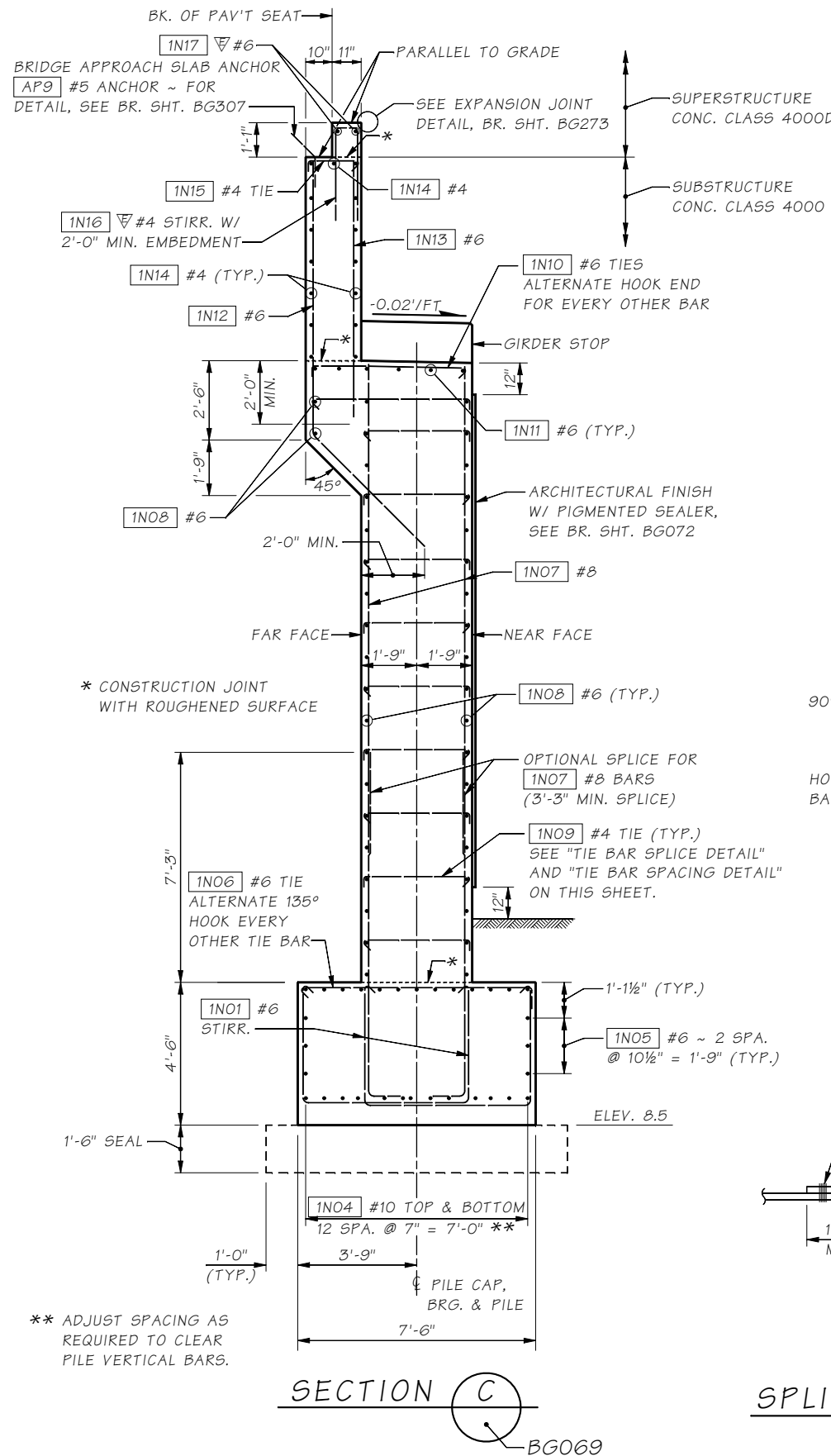

SECTION F

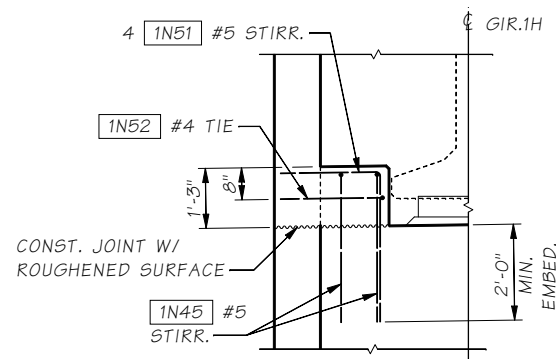

SECTION G

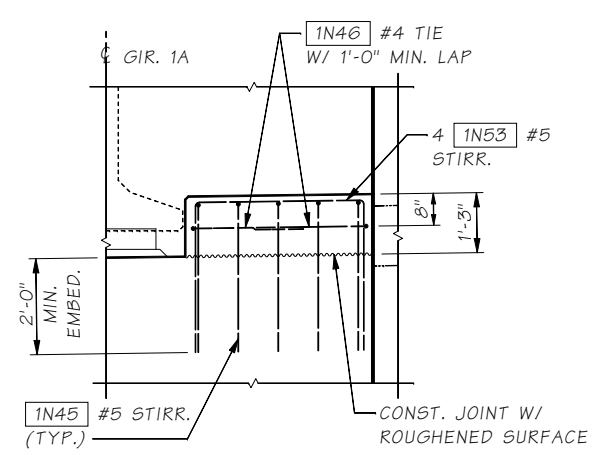

SECTION H

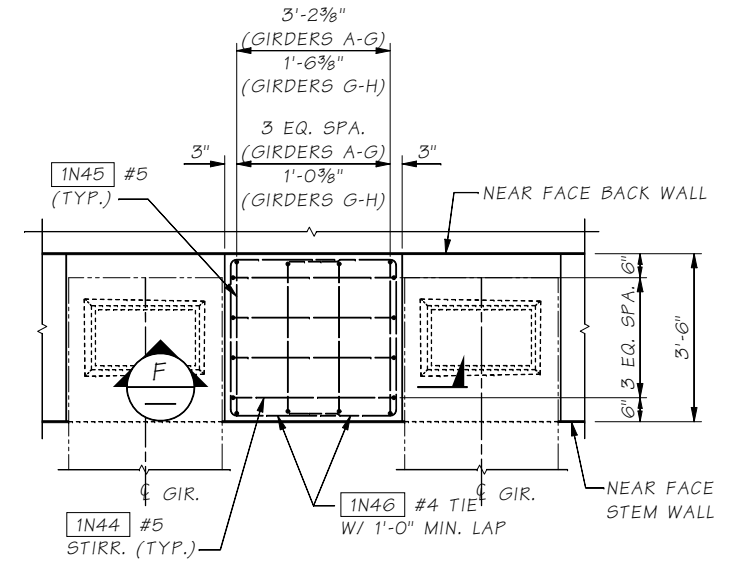

INTERIOR GIRDER STOP DETAIL

NOTE: SEE "GIRDER SEAT DETAIL" BR. SHT. BG142 FOR ADDITIONAL INFORMATION.

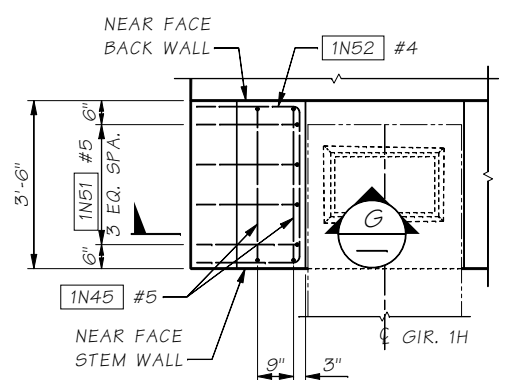

EXTERIOR GIRDER STOP DETAIL

CURTAIN WALL REINF. NOT SHOWN FOR CLARITY.

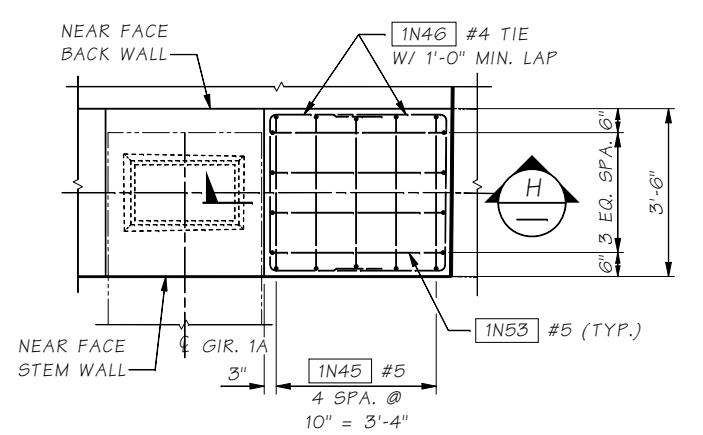

MEDIAN GIRDER STOP DETAIL

SECTION C

SR 99 FILE NO. SHEET BG071

Bridge Design Engr. Khaleghi, B	M:\Y-Team\AWV SOUTH INTERCHANGE\window files\Pier 1N Details.WND	REGION NO.	STATE	FED. AID PROJ. NO.	SHEET NO.	TOTAL SHEETS
Supervisor Moore, TM		10	WASH.			
Designed By Schultz, E	09/09	JOB NUMBER 09A803				
Checked By Lee, CS	09/09					
Detailed By Hanson, CE	09/09					
Bridge Projects Engr.						
Prelim. Plan By						
Architect/Specialist	DATE	REVISION	BY	APPD		



BRIDGE AND STRUCTURES OFFICE



SR 99
ALASKAN WAY VIADUCT - REPLACEMENT
S HOLGATE ST TO S KING ST - PHASE 2
BRIDGE NO. 99/540 NB & SB
PIER 1N DETAILS

BRIDGE SHEET NO. BG071
SHEET 917 OF 1475 SHEETS

TABLE OF ELEVATIONS		
PIER	ELEV. A	ELEV. B
PIER 1N (RIGHT)	38.22	38.01

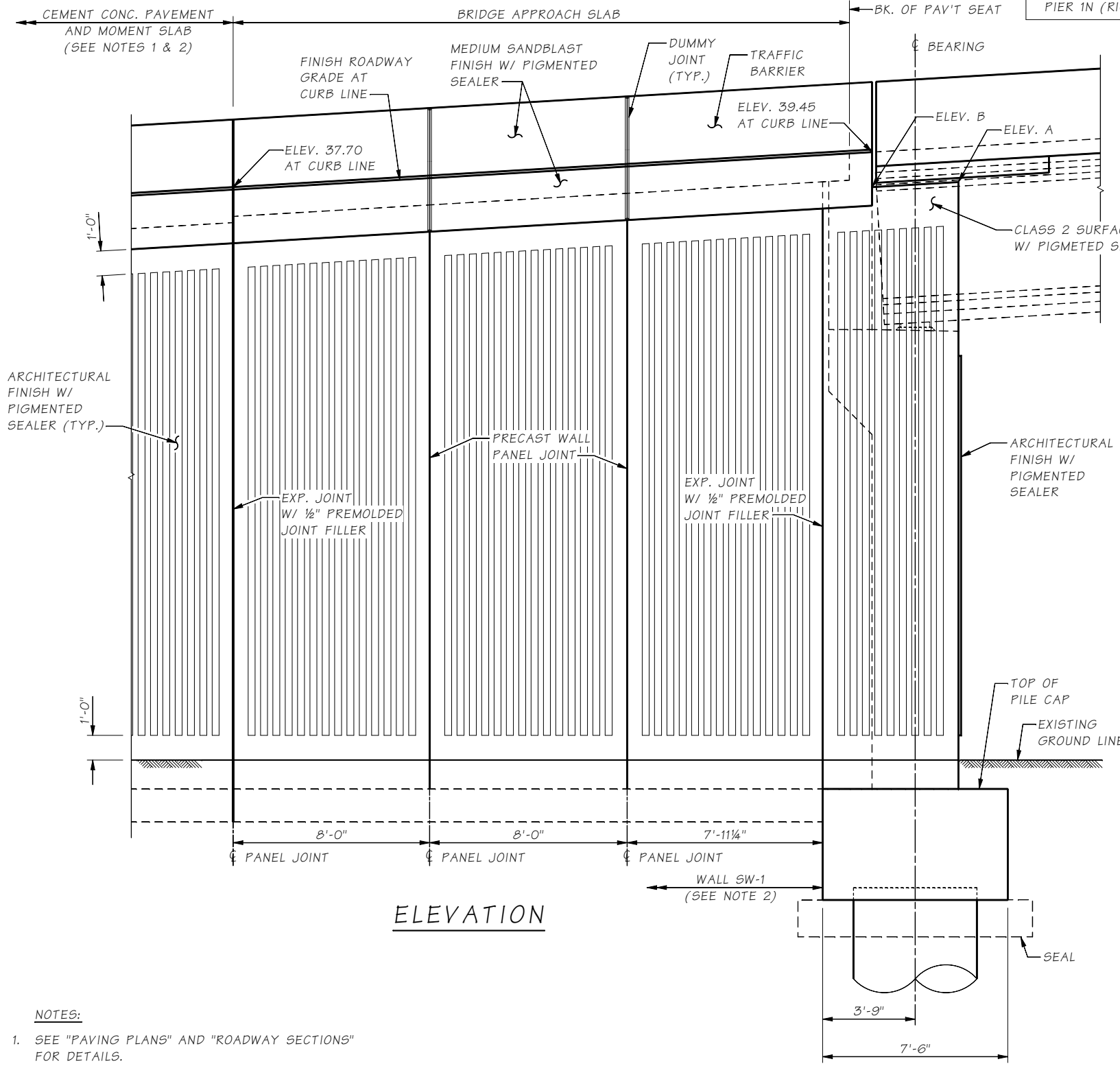

ELEVATION

- NOTES:**
- SEE "PAVING PLANS" AND "ROADWAY SECTIONS" FOR DETAILS.
 - SEE SL SERIES FOR WALL PLAN, ELEVATION AND SECTION DETAILS.
 - SEE BR. SHT. BG298 FOR BRIDGE DRAIN DETAILS.

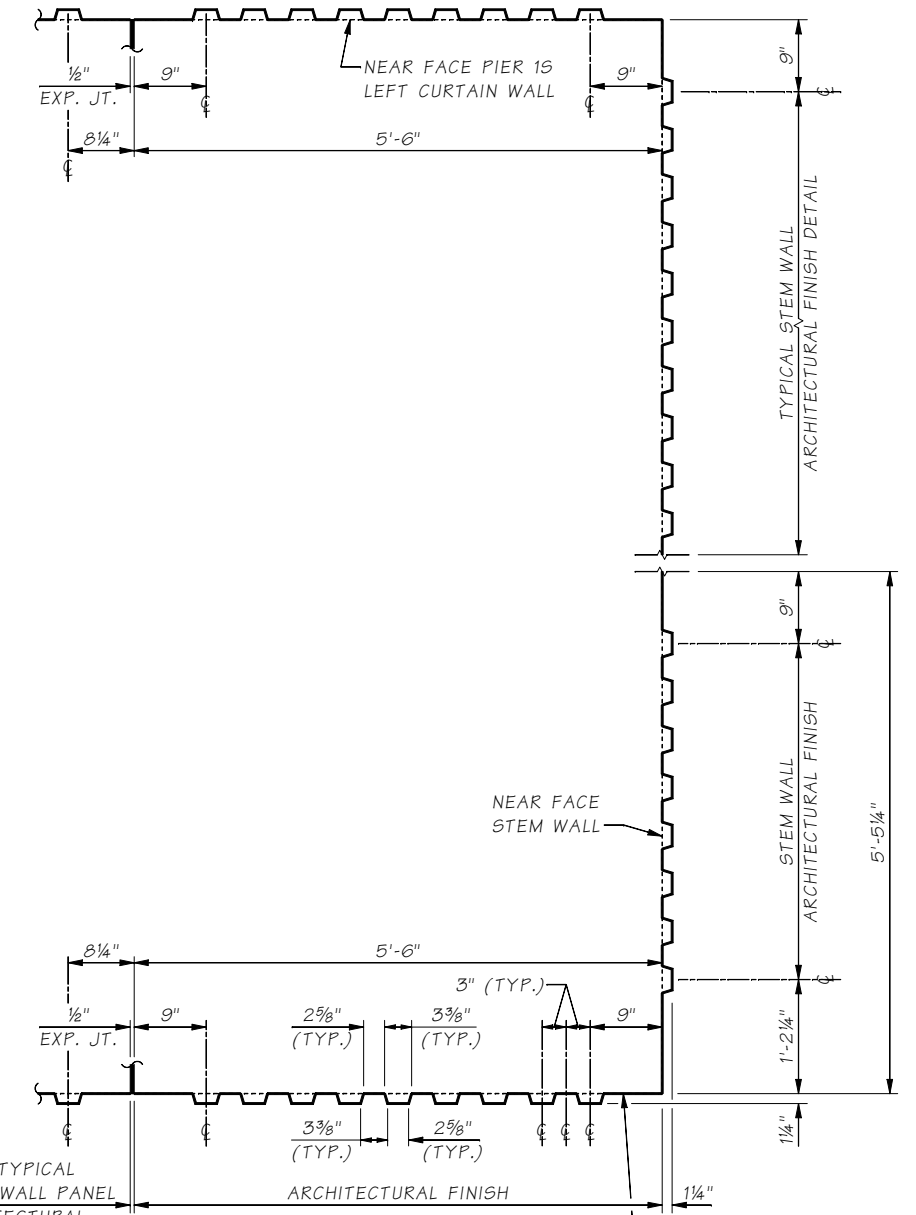

CURTAIN WALL ARCHITECTURAL FINISH DETAIL

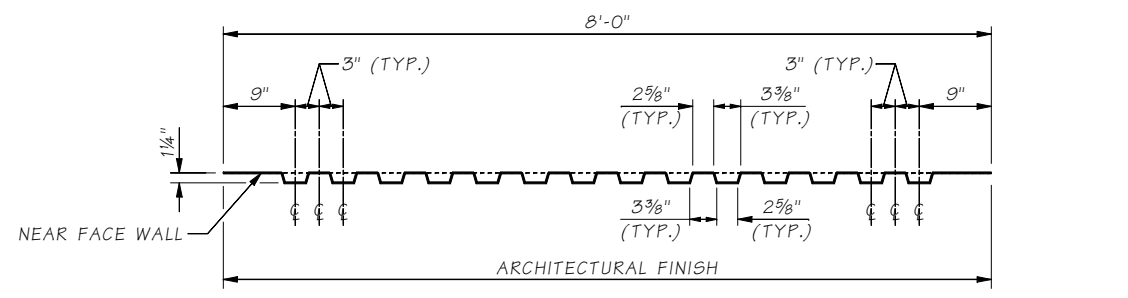

TYPICAL PRECAST WALL PANEL & STEM WALL ARCHITECTURAL FINISH DETAIL

SR 99 FILE NO. SHEET BG072

Bridge Design Engr.	Khaleghi, B	M:\Y-Team\AWV SOUTH INTERCHANGE\window files\Pier 1N Curtain wall.WND			
Supervisor	Moore, TM	REGION NO.	STATE	FED. AID PROJ. NO.	SHEET NO.
Designed By	Schultz, E 09/09	10	WASH.		TOTAL SHEETS
Checked By	Lee, CS 09/09	JOB NUMBER 09A803			
Detailed By	Hanson, CE 09/09				
Bridge Projects Engr.					
Prelim. Plan By					
Architect/Specialist		DATE	REVISION	BY	APPD



BRIDGE AND STRUCTURES OFFICE

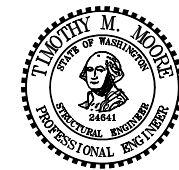

SR 99
ALASKAN WAY VIADUCT - REPLACEMENT
S HOLGATE ST TO S KING ST - PHASE 2
 BRIDGE NO. 99/540 NB & SB
PIER 1N CURTAIN WALL ELEVATION

BRIDGE SHEET NO. **BG072**
 SHEET **918** OF **1475** SHEETS

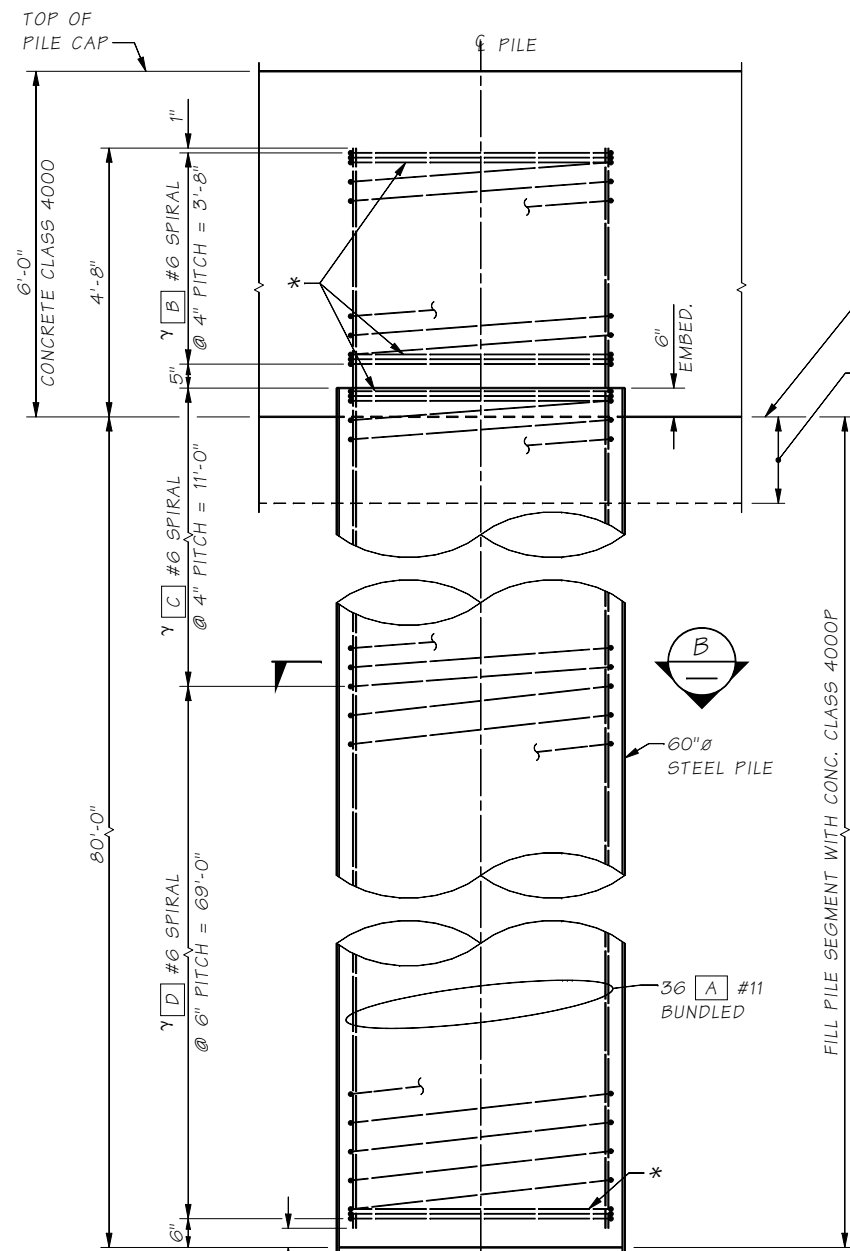

* SEE SPIRAL TERMINATION DETAIL ON THIS SHEET.

γ WELDED SPLICE ONLY (SEE WELDED LAP SPLICE DETAIL ON THIS SHEET)

FIELD SPLICE LOCATION (PER CONTRACTOR) FOR FIT UP SEE DETAIL (W)

MIN. TIP ELEVATION SEE SPECIAL PROVISIONS

OPEN END WITH CUTTING SHOE, SEE "PILE TIP DETAIL" ON THIS SHEET

TYPICAL PILE ELEVATION

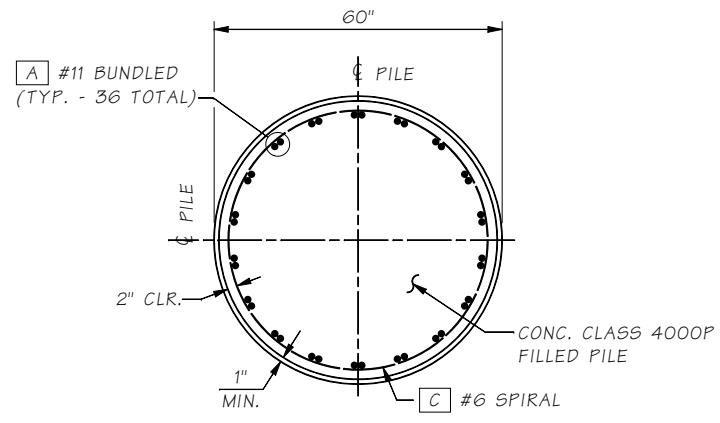

SECTION B

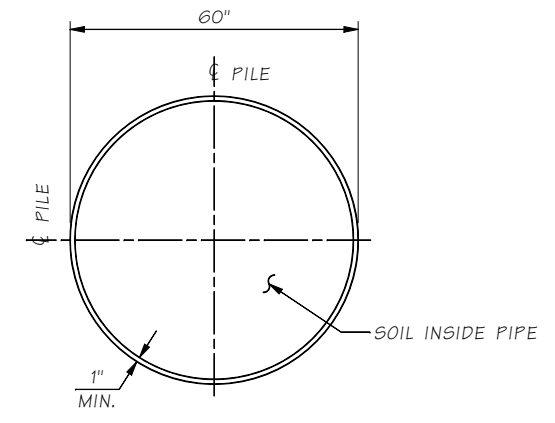

SECTION A

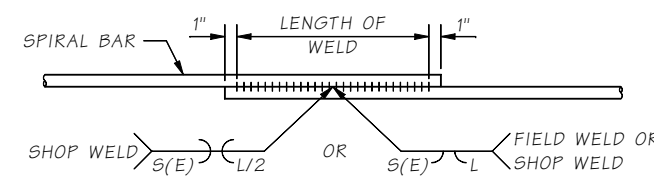

WELDED LAP SPLICE DETAIL

WELDING SHALL MEET THE REQUIREMENTS OF STD. SPEC. 6-02.3(24)E FOR WELD DIMENSIONS, SEE TABLE BELOW.

DEFORMED BAR	WELD DIMENSIONS		
	S	E	LENGTH (L)
#6	3/8	3/16	6"

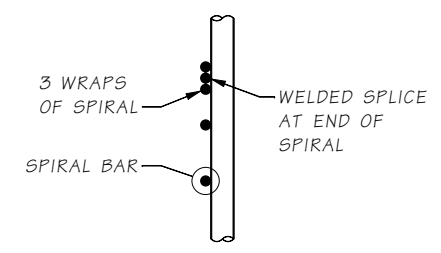

SPIRAL TERMINATION DETAIL

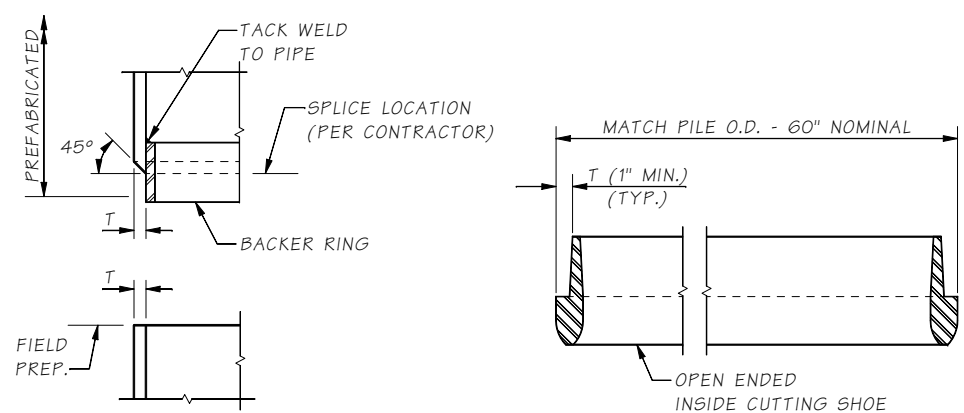

PILE TIP DETAIL

PERMISSIBLE WELD SPLICE DETAILS FOR STEEL PIPE PILES. SEE "100% U.T. INSPECTION LIMITS" ON BR. SHT. BGO67 FOR WELDING INSPECTION REQUIREMENTS.

DETAIL W

PILE BAR LIST							
ALL REINFORCING SHALL BE ASTM A 706							
PIER	PILES REQUIRED PER PIER	MARK	BAR SIZE	BARS PER PILE	LENGTH PER PILE	BEND TYPE	WT. (LBS.) PER PILE
2N	8	A	#11	36	84'-4"	STRAIGHT	16,131
		B	#6	1	(a)	SPIRAL	324
		C	#6	1	(a)	SPIRAL	755
		D	#6	1	(a)	SPIRAL	3,022
TOTAL							20,232

(a) ~ DETERMINED FROM PLANS

SPIRAL WEIGHT INCLUDES SPLICES

SR 99 FILE NO. SHEET BGO73

Bridge Design Engr. Khaleghi, B	M:\Y-Team\AWV SOUTH INTERCHANGE\window files\Pier 2N Pile Dtls.WND		
Supervisor Moore, TM	REGION NO.	STATE	FED. AID PROJ. NO.
Designed By Schultz, E 09/09	10	WASH.	
Checked By Lee, CS 09/09	JOB NUMBER	SHEET NO. TOTAL SHEETS	
Detailed By Hanson, CE 09/09	09A803		
Bridge Projects Engr.	DATE	REVISION	BY APPD
Prelim. Plan By			
Architect/Specialist			



BRIDGE AND STRUCTURES OFFICE

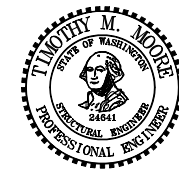

SR 99
ALASKAN WAY VIADUCT - REPLACEMENT
S HOLGATE ST TO S KING ST - PHASE 2
BRIDGE NO. 99/540 NB & SB
PIER 2N PILE DETAILS

BRIDGE SHEET NO. BGO73
SHEET 919 OF 1475 SHEETS

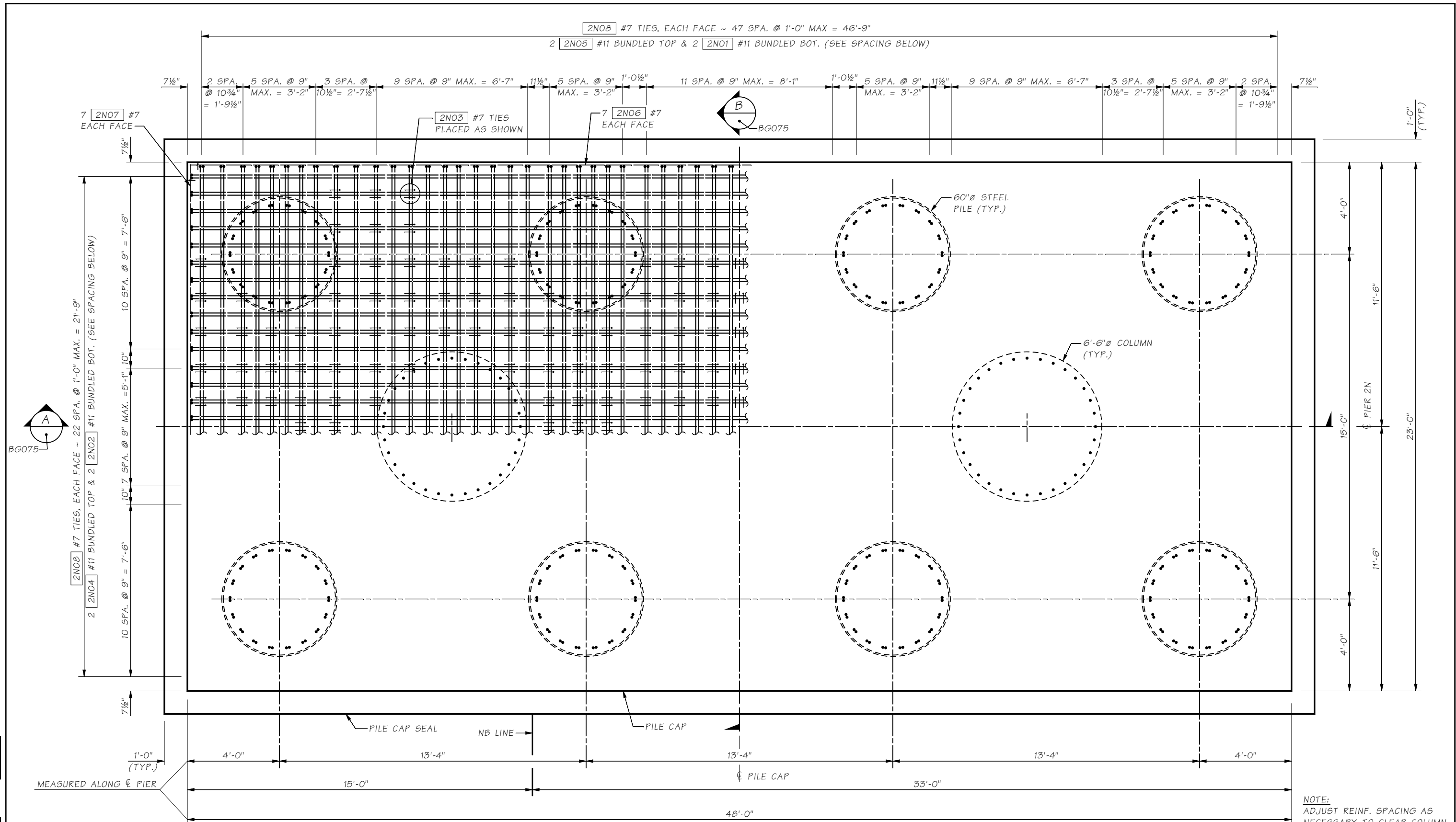

PLAN

NOTE:
ADJUST REINF. SPACING AS
NECESSARY TO CLEAR COLUMN
AND PILE VERTICAL BARS.

SR 99 FILE NO. SHEET BG074

Bridge Design Engr.	Khaleghi, B	M:\Y-Team\AWV SOUTH INTERCHANGE\window files\Pier 2N Pile Cap Plan.WND			
Supervisor	Moore, TM	REGION NO.	STATE	FED. AID PROJ. NO.	SHEET NO.
Designed By	Schultz, E	10	WASH.		TOTAL SHEETS
Checked By	Lee, CS	JOB NUMBER			
Detailed By	Hanson, CE	09A803			
Bridge Projects Engr.		DATE	REVISION	BY	APPD
Prelim. Plan By					
Architect/Specialist					



BRIDGE AND STRUCTURES OFFICE

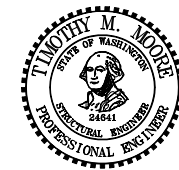

SR 99
ALASKAN WAY VIADUCT - REPLACEMENT
S HOLGATE ST TO S KING ST - PHASE 2
BRIDGE NO. 99/540 NB & SB

PIER 2N PILE CAP PLAN

BRIDGE SHEET NO. BG074
SHEET 920 OF 1475 SHEETS

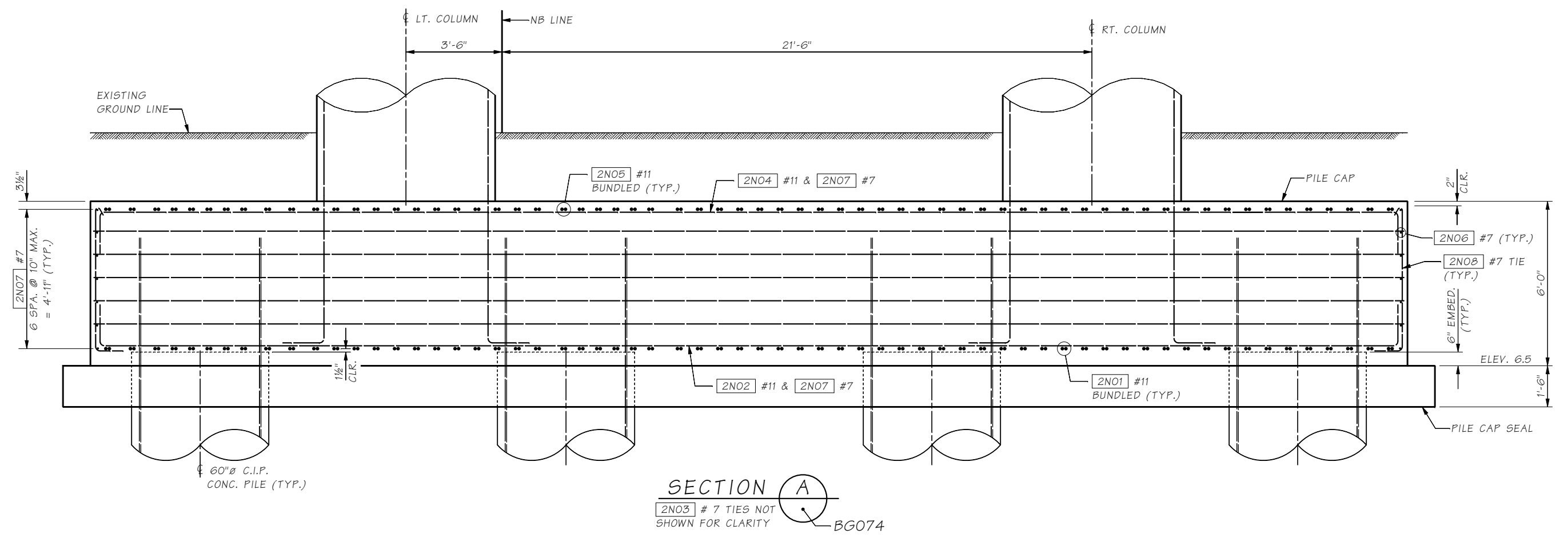
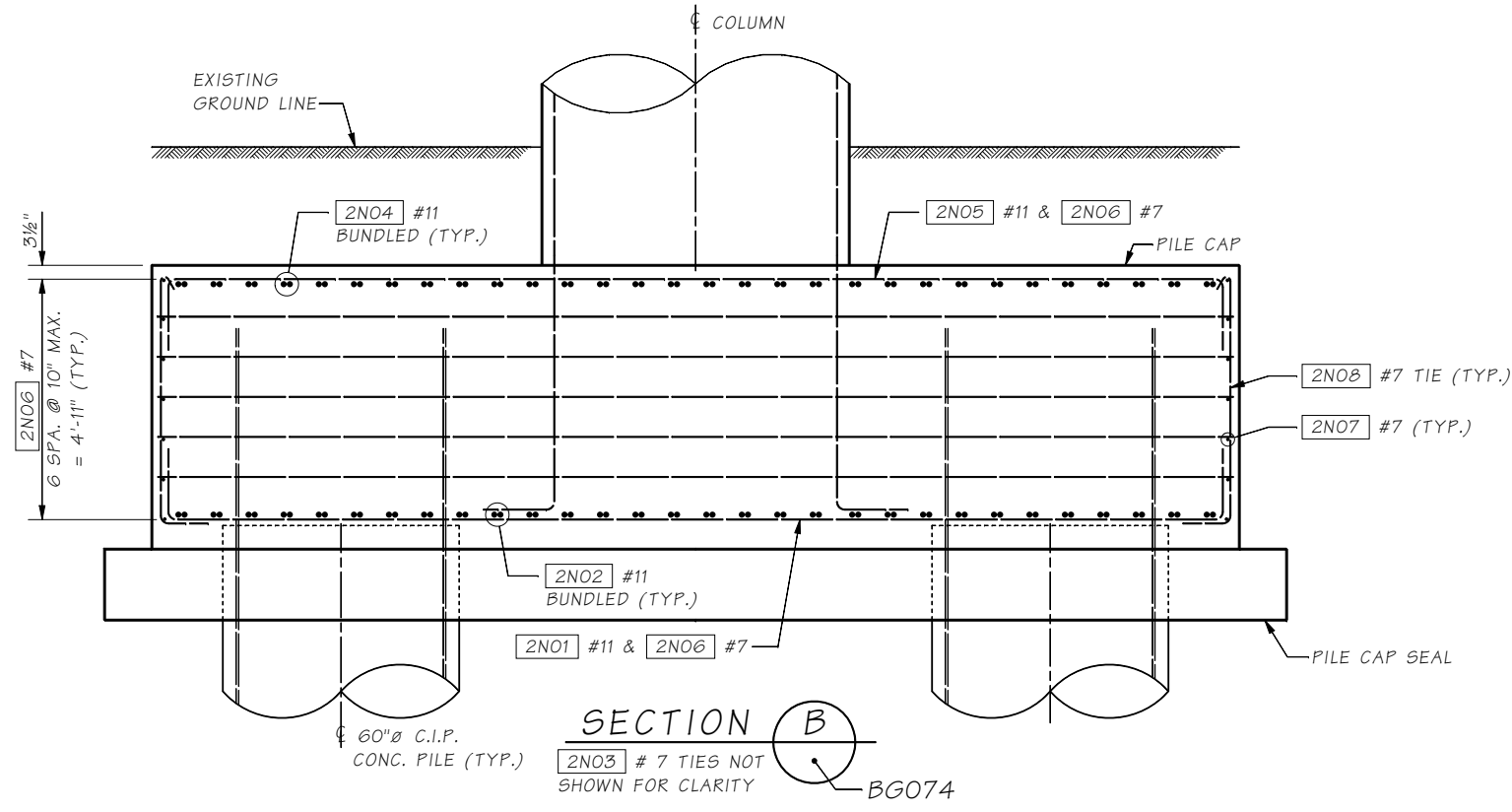

SR 99 FILE NO. SHEET BG075

Bridge Design Engr.	Khaleghi, B	M:\Y-Team\AWV SOUTH INTERCHANGE\window files\Pier 2N Pile Cap Elev.WND			
Supervisor	Moore, TM	REGION NO.	STATE	FED. AID PROJ. NO.	SHEET NO.
Designed By	Schultz, E	10	WASH.		TOTAL SHEETS
Checked By	Lee, CS	JOB NUMBER 09A803			
Detailed By	Hanson, CE				
Bridge Projects Engr.					
Prelim. Plan By					
Architect/Specialist		DATE	REVISION	BY	APPD



BRIDGE AND STRUCTURES OFFICE

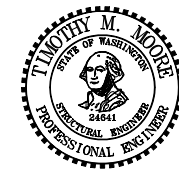

SR 99
ALASKAN WAY VIADUCT - REPLACEMENT
S HOLGATE ST TO S KING ST - PHASE 2
BRIDGE NO. 99/540 NB & SB
PIER 2N PILE CAP ELEVATION

BRIDGE SHEET NO. BG075
SHEET 921 OF 1475 SHEETS

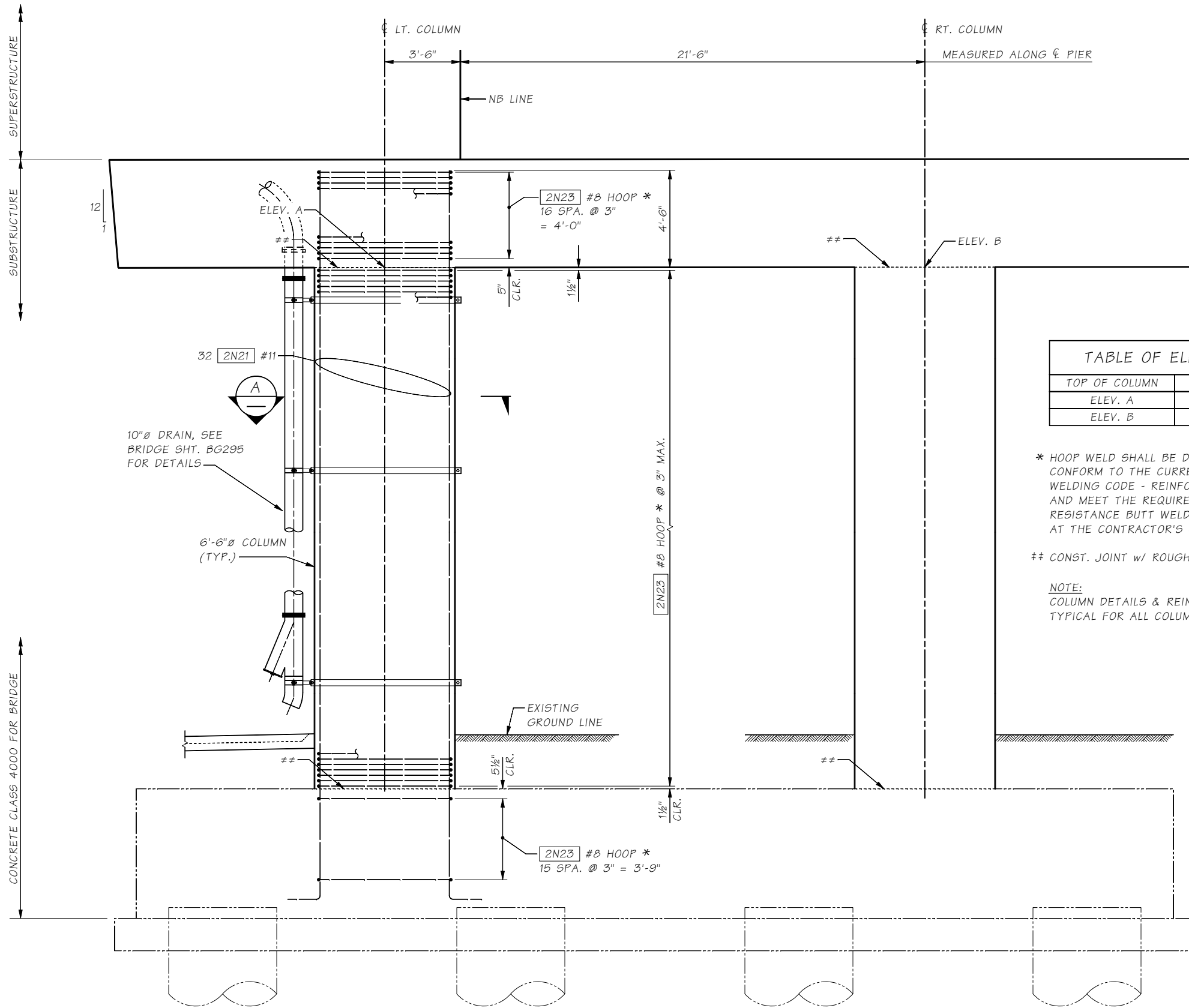

COLUMN ELEVATION - PIER 2N

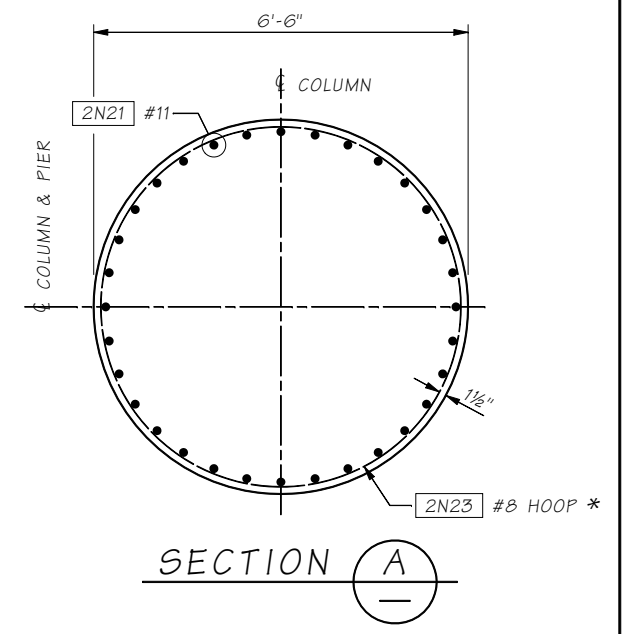
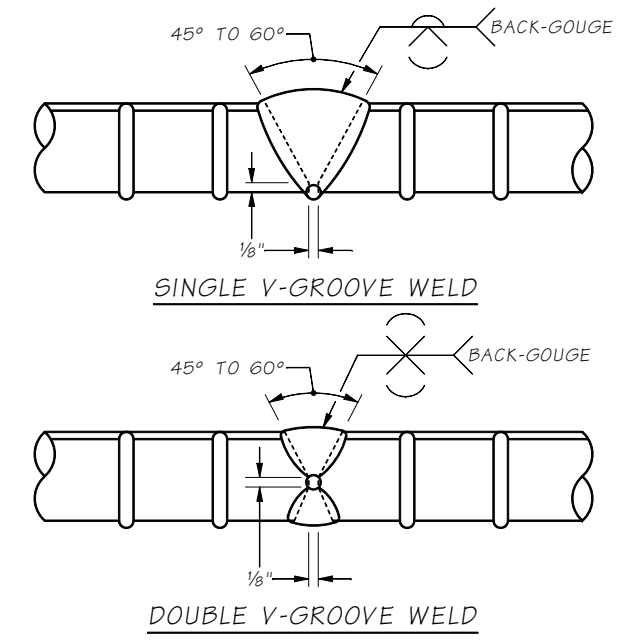

TABLE OF ELEVATIONS	
TOP OF COLUMN	ELEVATION
ELEV. A	36.44
ELEV. B	36.46

* HOOP WELD SHALL BE DIRECT BUTT-WELDED AND CONFORM TO THE CURRENT EDITION OF STRUCTURAL WELDING CODE - REINFORCING STEEL OF AWS(D1.4) AND MEET THE REQUIREMENTS OF STD. SPEC. 6-02.3(24)E. RESISTANCE BUTT WELDED SPLICE MAY BE SUBSTITUTED AT THE CONTRACTOR'S OPTION. SEE SPECIAL PROVISIONS.

CONST. JOINT w/ ROUGHENED SURFACE

NOTE:
COLUMN DETAILS & REINFORCING
TYPICAL FOR ALL COLUMNS.



HOOP WELD DETAIL

ALL BACKING SHALL BE REMOVED

SR 99 FILE NO. SHEET BG076

Bridge Design Engr. Khaleghi, B	M:\Y-Team\AWV SOUTH INTERCHANGE\window files\Pier 2N Col Dtl's.WND				REGION NO.	STATE	FED. AID PROJ. NO.	SHEET NO.	TOTAL SHEETS
Supervisor Moore, TM					10	WASH.			
Designed By Lee, CS	09/09								
Checked By Schultz, E	09/09								
Detailed By Hanson, CE	09/09								
Bridge Projects Engr.					JOB NUMBER				
Prelim. Plan By					09A803				
Architect/Specialist	DATE	REVISION	BY	APPD					



BRIDGE AND STRUCTURES OFFICE



SR 99
ALASKAN WAY VIADUCT - REPLACEMENT
S HOLGATE ST TO S KING ST - PHASE 2
BRIDGE NO. 99/540 NB & SB
PIER 2N COLUMN DETAILS

BRIDGE SHEET NO. BG076
SHEET 922 OF 1475 SHEETS

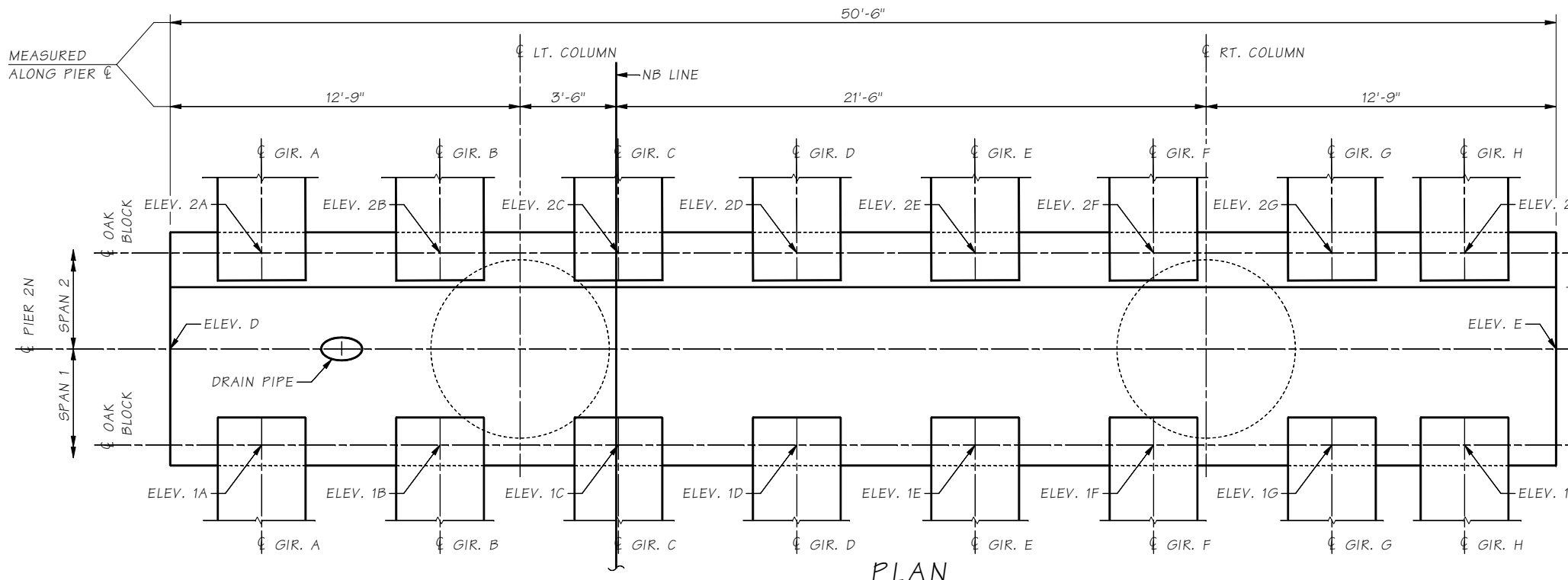

PLAN

LOCATION	1A	1B	1C	1D	1E	1F	1G	1H
SPAN 1 GIRDERS	41.68	41.69	41.69	41.70	41.70	41.71	41.71	41.72

LOCATION	2A	2B	2C	2D	2E	2F	2G	2H
SPAN 2 GIRDERS	42.18	42.20	42.22	42.23	42.25	42.27	42.29	42.30

LOCATION	ELEVATION
D	41.43
E	41.47
F	49.02
G	49.11

NOTE:
SEE FRAMING PLAN FOR GIRDER SPACING.

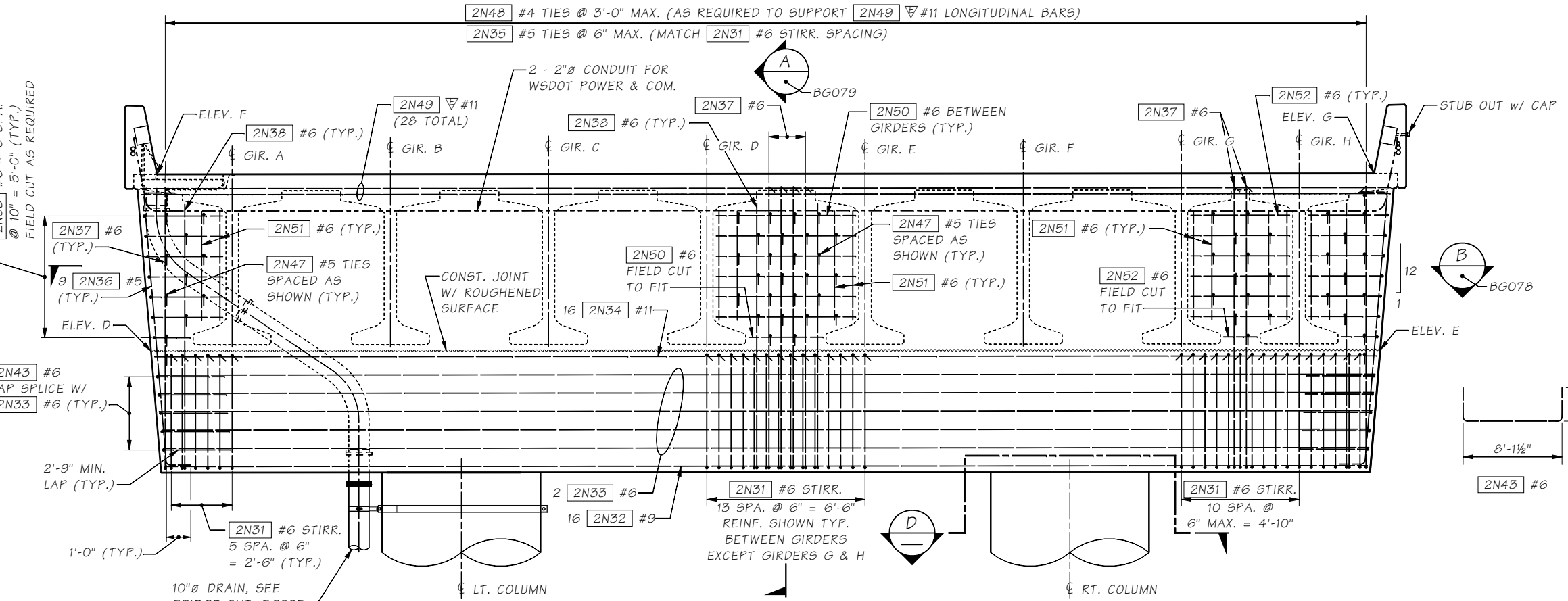

ELEVATION

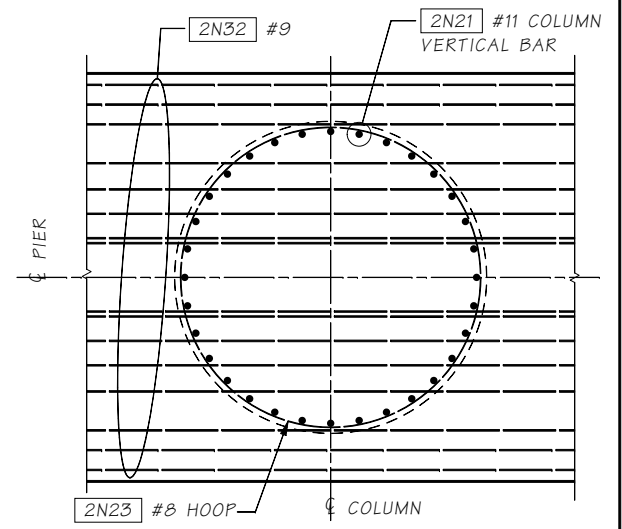

SECTION D

TRANSVERSE REINFORCING NOT SHOWN FOR CLARITY. ADJUST LONGITUDINAL BAR, TRANSVERSE STIRRUP, AND THE TIE SPACING AS REQUIRED TO CLEAR COLUMN VERTICAL BARS.

- NOTES:
1. SLAB REINFORCING NOT SHOWN FOR CLARITY.
 2. ADJUST STIRRUP AND TIE SPACING AS REQUIRED TO CLEAR COLUMN VERTICAL BARS.
 3. DIAPHRAGM REINFORCING SHOWN FOR SPAN 1 FACE ONLY. SEE SECTION B FOR DETAILS.

SR 99 FILE NO. SHEET BG077

Bridge Design Engr. Khaleghi, B	M:\Y-Team\AWV SOUTH INTERCHANGE\window files\Pier 2N X-Beam Plan-Elev.WND			
Supervisor Moore, TM	REGION NO. 10	STATE WASH.	FED. AID PROJ. NO.	SHEET NO.
Designed By Lee, CS 09/08	JOB NUMBER 09A803			
Checked By Glassford, P 09/09	DATE	REVISION	BY	APPD
Detailed By Hanson, CE 09/08				
Bridge Projects Engr.				
Prelim. Plan By				
Architect/Specialist				



BRIDGE AND STRUCTURES OFFICE

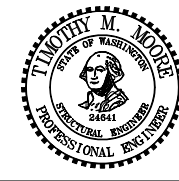

SR 99
ALASKAN WAY VIADUCT - REPLACEMENT
S HOLGATE ST TO S KING ST - PHASE 2
BRIDGE NO. 99/540 NB & SB
PIER 2N CROSSBEAM
PLAN AND ELEVATION

BRIDGE SHEET NO. BG077
SHEET 923 OF 1475 SHEETS

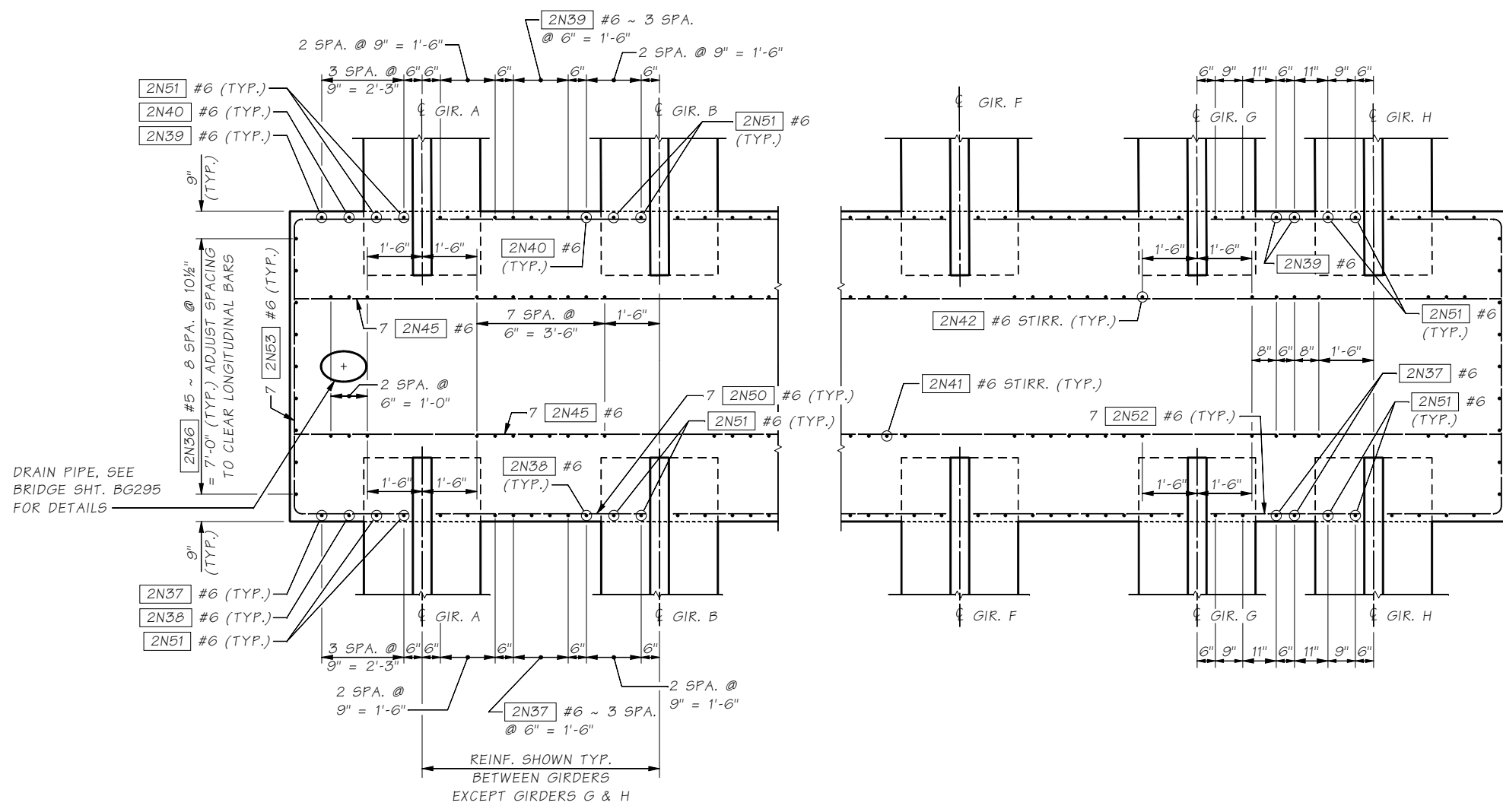

SECTION B
BG077

Bridge Design Engr.	Khaleghi, B	M:\Y-Team\AWV SOUTH INTERCHANGE\window files\Pier 2N X-Beam Dtls.WND			
Supervisor	Moore, TM	REGION NO.	STATE	FED. AID PROJ. NO.	SHEET NO.
Designed By	Lee, CS	10	WASH.		TOTAL SHEETS
Checked By	Glassford, P	JOB NUMBER 09A803			
Detailed By	Hanson, CE				
Bridge Projects Engr.					
Prelim. Plan By					
Architect/Specialist		DATE	REVISION	BY	APPD



BRIDGE AND STRUCTURES OFFICE

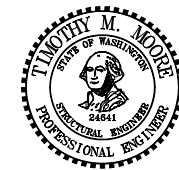

SR 99
ALASKAN WAY VIADUCT - REPLACEMENT
S HOLGATE ST TO S KING ST - PHASE 2
BRIDGE NO. 99/540 NB & SB
PIER 2N CROSSBEAM DETAILS 1 OF 2

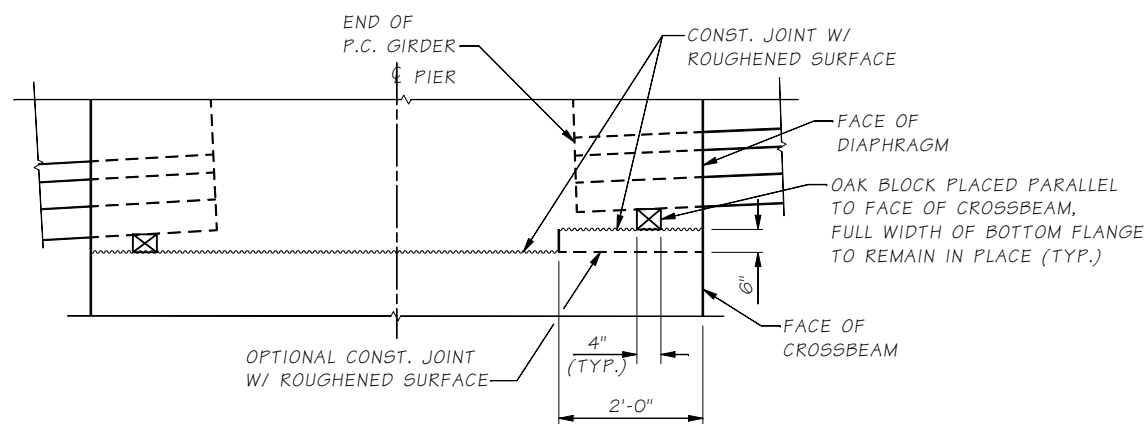

OAK BLOCK DETAIL
LONGITUDINAL DIMENSIONS ARE NORMAL TO SKEW

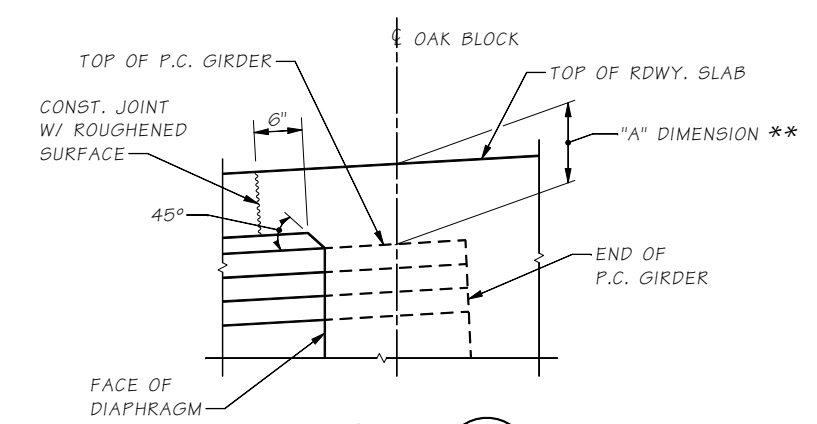

DETAIL C
REINFORCING NOT SHOWN FOR CLARITY

** SEE "GIRDER SCHEDULE" SHEETS

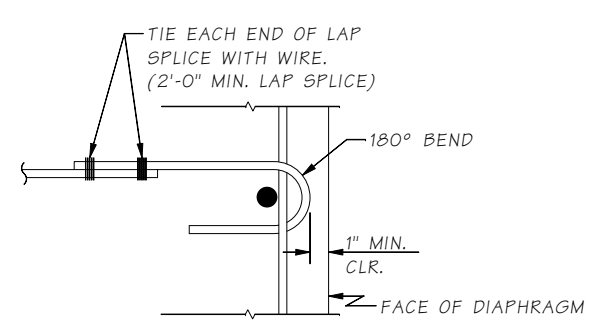

TIE BAR DETAIL

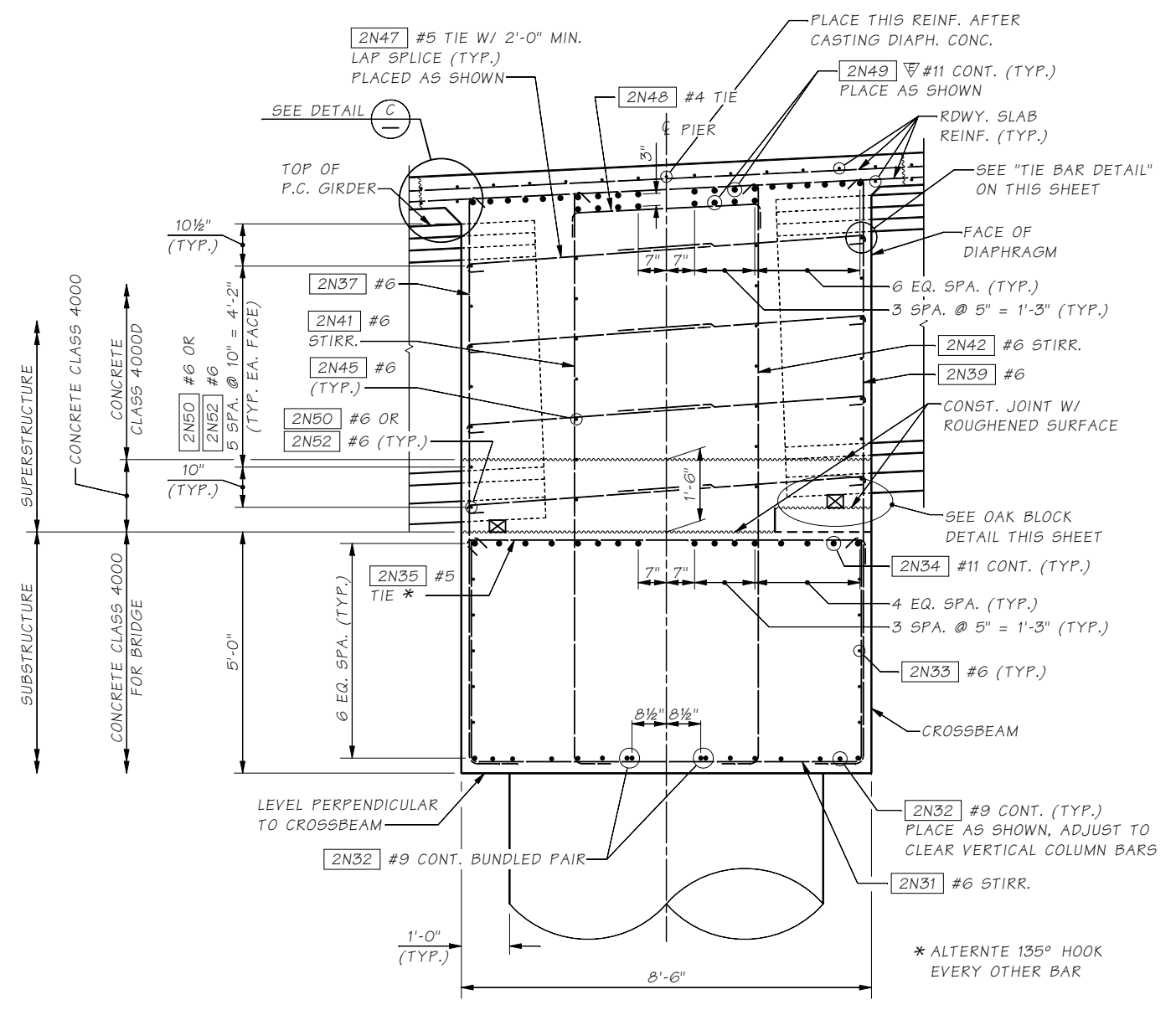

SECTION A

- NOTES:
- LONGITUDINAL DIMENSIONS ARE NORMAL TO SKEW.
 - FOR CONCRETE PLACEMENT PROCEDURE, SEE "CONSTRUCTION SEQUENCE" SHEET.

SR 99 FILE NO. SHEET BG079

Bridge Design Engr.	Khaleghi, B	M:\Y-Team\AWV SOUTH INTERCHANGE\window files\Pier 2N X-Beam Dtls 2.WND			
Supervisor	Moore, TM	REGION NO.	STATE	FED. AID PROJ. NO.	SHEET NO.
Designed By	Lee, CS 05/09	10	WASH.		TOTAL SHEETS
Checked By	Glassford, P 09/09	JOB NUMBER 09A803			
Detailed By	Hanson, CE 05/09				
Bridge Projects Engr.					
Prelim. Plan By					
Architect/Specialist		DATE	REVISION	BY	APPD



BRIDGE AND STRUCTURES OFFICE

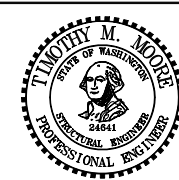

SR 99
ALASKAN WAY VIADUCT - REPLACEMENT
S HOLGATE ST TO S KING ST - PHASE 2
BRIDGE NO. 99/540 NB & SB
PIER 2N CROSSBEAM DETAILS 2 OF 2

BRIDGE SHEET NO. BG079
SHEET 925 OF 1475 SHEETS

SR 99 FILE NO. SHEET BG080

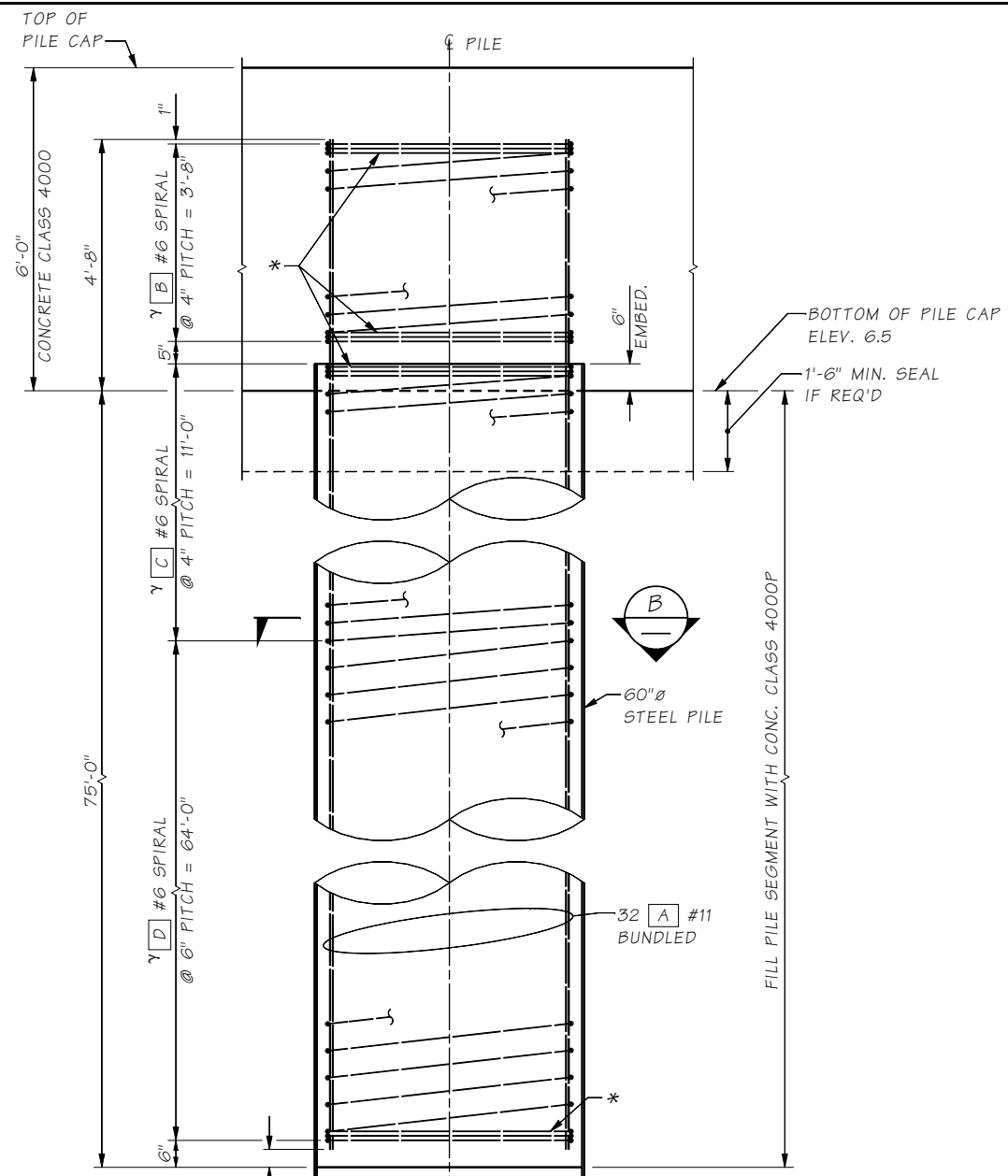

FIELD SPLICE LOCATION (PER CONTRACTOR) FOR FIT UP SEE DETAIL (W)

MIN. TIP ELEVATION SEE SPECIAL PROVISIONS

OPEN END WITH CUTTING SHOE, SEE "PILE TIP DETAIL" ON THIS SHEET

TYPICAL PILE ELEVATION

* SEE SPIRAL TERMINATION DETAIL ON THIS SHEET.

WELDED SPLICE ONLY (SEE WELDED LAP SPLICE DETAIL ON THIS SHEET)

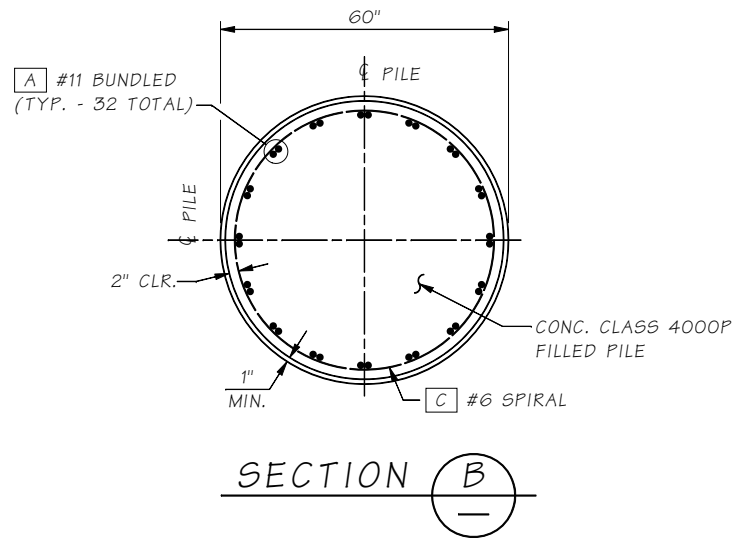

SECTION B

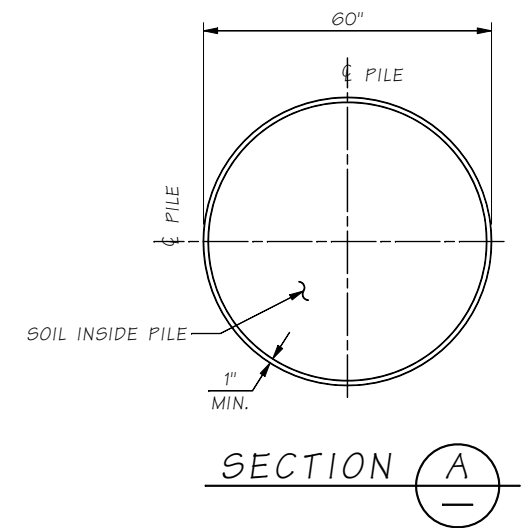

SECTION A

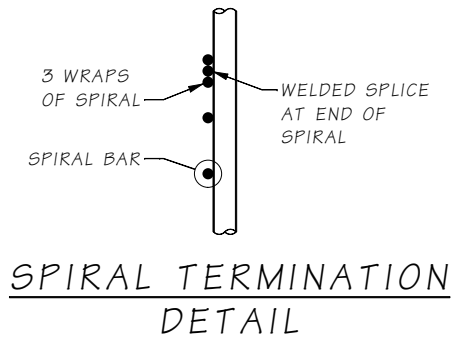

SPIRAL TERMINATION DETAIL

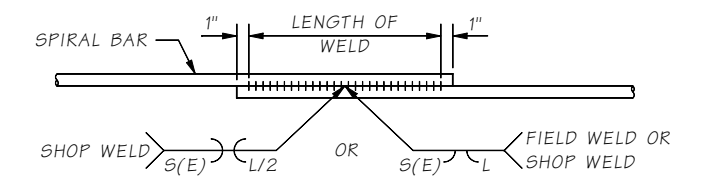

WELDED LAP SPLICE DETAIL

WELDING SHALL MEET THE REQUIREMENTS OF STD. SPEC. 6-02.3(24)E FOR WELD DIMENSIONS, SEE TABLE BELOW.

DEFORMED BAR	WELD DIMENSIONS		
	S	E	LENGTH (L)
#6	3/8	3/16	6"

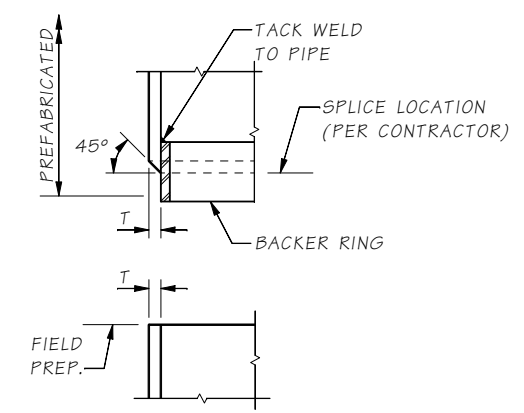

DETAIL W

PERMISSIBLE WELD SPLICE DETAILS FOR STEEL PIPE PILES. SEE "100% U.T. INSPECTION LIMITS" ON BR. SHT. BG067 FOR WELDING INSPECTION REQUIREMENTS.

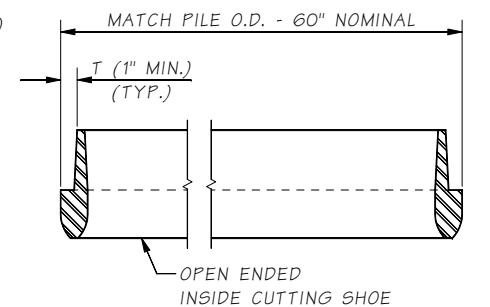

PILE TIP DETAIL

STEEL PILE WALL THICKNESS (T) AND CUTTING SHOE THICKNESS SHALL BE DETERMINED BY CONTRACTOR. SEE STD. SPEC. 6-05.3(B)

PILE BAR LIST

ALL REINFORCING SHALL BE ASTM A 706

PIER	PILES REQUIRED PER PIER	MARK	BAR SIZE	BARS PER PILE	LENGTH	BEND TYPE	WT. (LBS.) PER PILE
3N	8	A	#11	32	79'-4"	STRAIGHT	13,489
		B	#6	1	(a)	SPIRAL	324
		C	#6	1	(a)	SPIRAL	755
		D	#6	1	(a)	SPIRAL	2,806
TOTAL							17,374



SPIRAL WEIGHT INCLUDES SPLICES

(a) ~ DETERMINED FROM PLANS

Bridge Design Engr. Khaleghi, B	M:\Y-Team\AWV SOUTH INTERCHANGE\window files\Pier 3N Pile Dtls.WND			
Supervisor Moore, TM	REGION NO.	STATE	FED. AID PROJ. NO.	SHEET NO.
Designed By Schultz, E 09/09	10	WASH.		TOTAL SHEETS
Checked By Lee, CS 09/09	JOB NUMBER 09A803			
Detailed By Hanson, CE 09/09				
Bridge Projects Engr.	DATE	REVISION	BY	APPD
Prelim. Plan By				
Architect/Specialist				



BRIDGE AND STRUCTURES OFFICE



SR 99
ALASKAN WAY VIADUCT - REPLACEMENT
S HOLGATE ST TO S KING ST - PHASE 2
BRIDGE NO. 99/540 NB & SB
PIER 3N PILE DETAILS

BRIDGE SHEET NO. BG080
SHEET 926 OF 1475 SHEETS

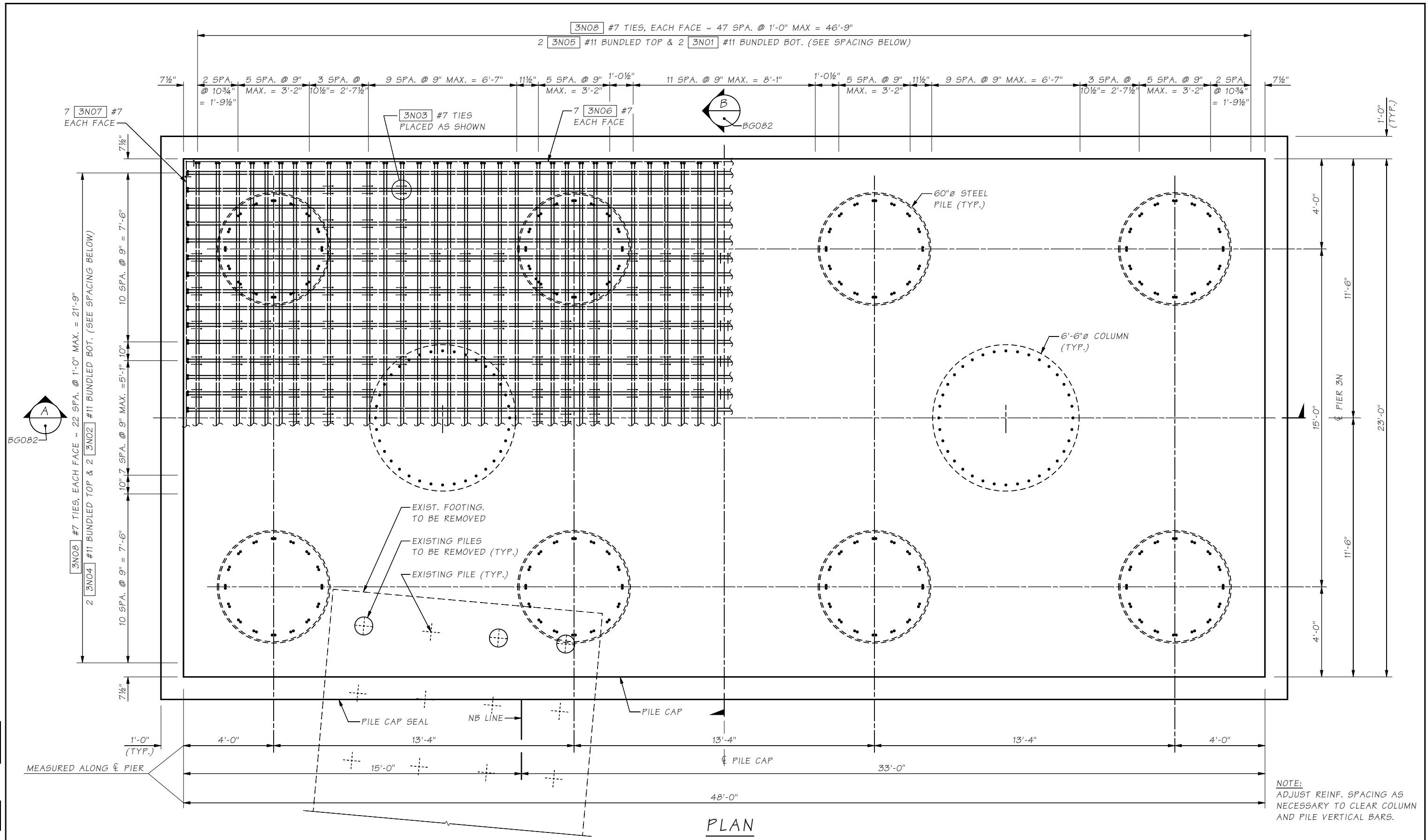

PLAN

SR 99 FILE NO. SHEET BG081

Bridge Design Engr.	Khaleghi, B	M:\Y-Team\AWV SOUTH INTERCHANGE\window files\Pier 3N Pile Cap Plan.WND			
Supervisor	Moore, TM	REGION NO.	STATE	FED. AID PROJ. NO.	SHEET NO.
Designed By	Schultz, E 09/09	10	WASH.		TOTAL SHEETS
Checked By	Lee, CS 09/09	JOB NUMBER 09A803			
Detailed By	Hanson, CE 09/09				
Bridge Projects Engr.		DATE	REVISION	BY	APPD
Prelim. Plan By		2/17/10	REVISED SHEET	CSL	TMM
Architect/Specialist					



BRIDGE AND STRUCTURES OFFICE

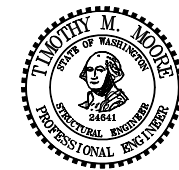

SR 99
ALASKAN WAY VIADUCT - REPLACEMENT
S HOLGATE ST TO S KING ST - PHASE 2
BRIDGE NO. 99/540 NB & SB

PIER 3N PILE CAP PLAN

BRIDGE SHEET NO. BG081
SHEET 927 OF 1475 SHEETS

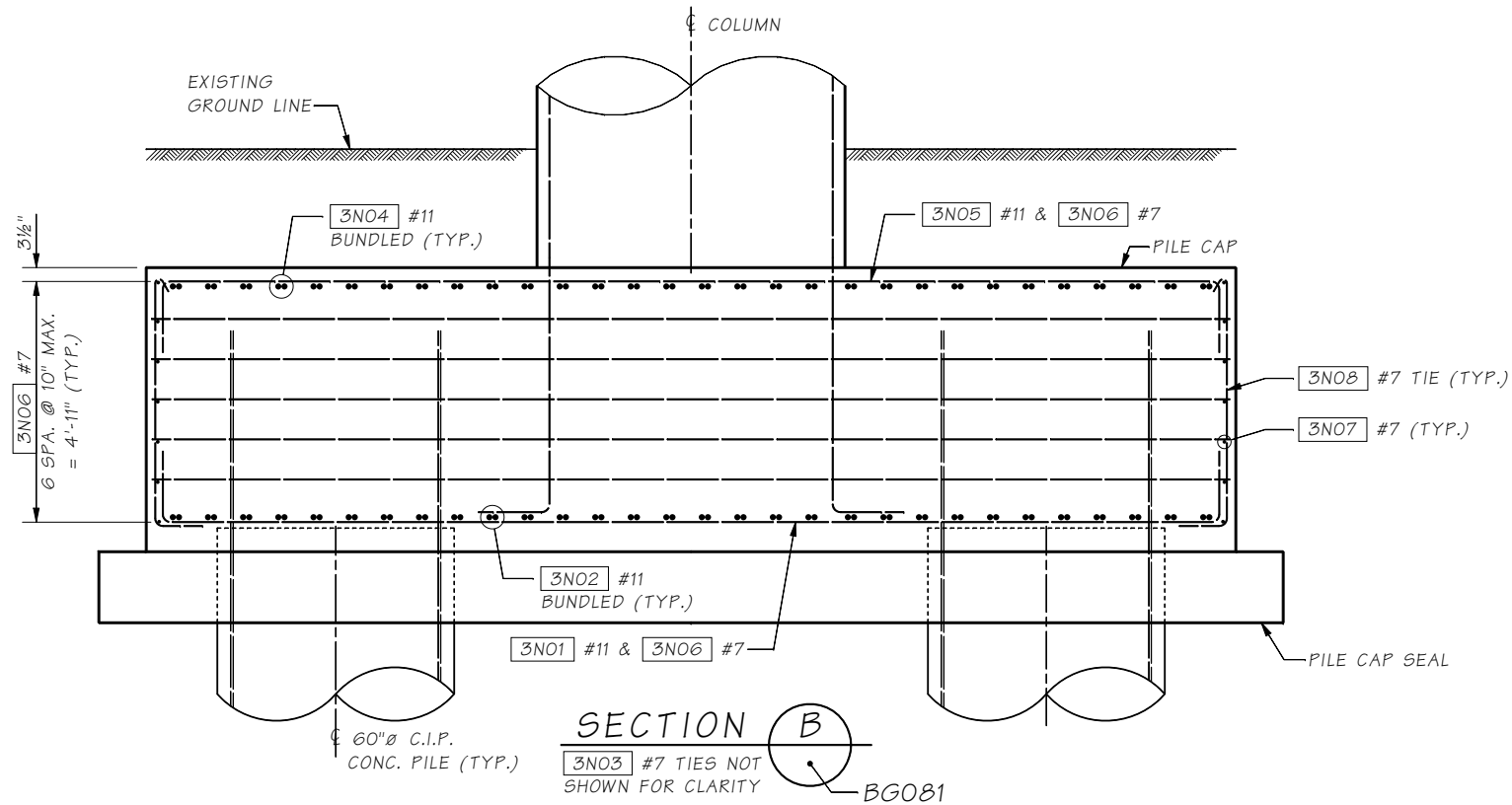

SECTION B
 3N03 #7 TIES NOT SHOWN FOR CLARITY
 BG081

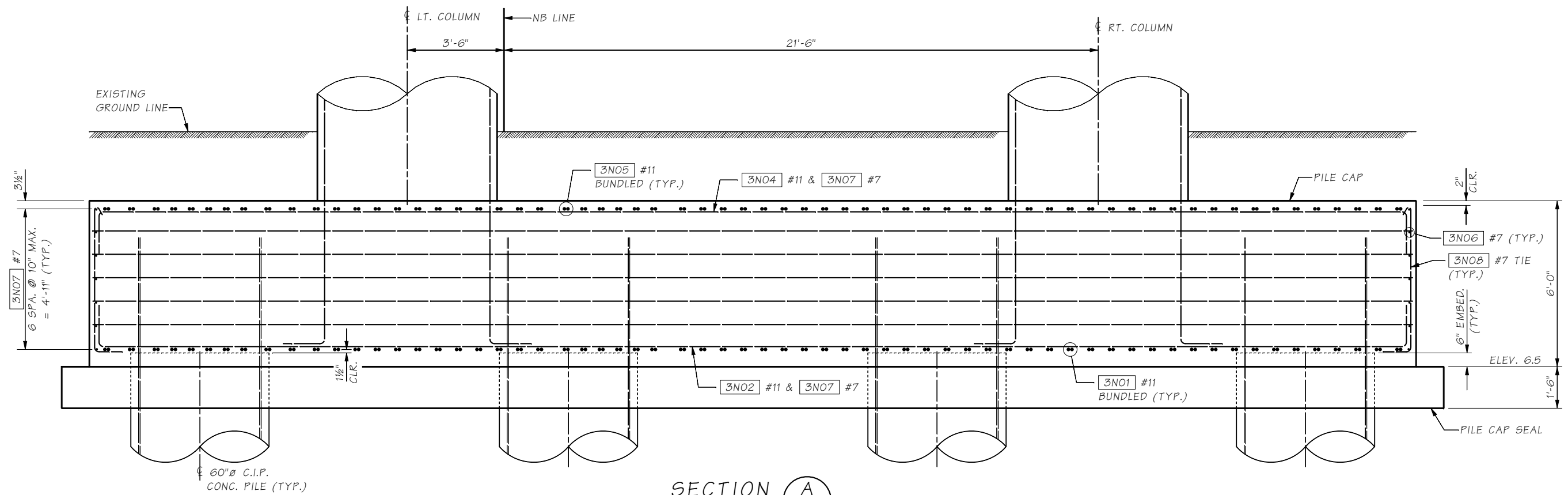

SECTION A
 3N03 #7 TIES NOT SHOWN FOR CLARITY
 BG081

SR 99 FILE NO. SHEET BG082

Bridge Design Engr.	Khaleghi, B	M:\Y-Team\AWV SOUTH INTERCHANGE\window files\Pier 3N Pile Cap Elev.WND			
Supervisor	Moore, TM	REGION NO.	STATE	FED. AID PROJ. NO.	SHEET NO.
Designed By	Schultz, E 09/09	10	WASH.		TOTAL SHEETS
Checked By	Lee, CS 09/09	JOB NUMBER 09A803			
Detailed By	Hanson, CE 09/09				
Bridge Projects Engr.		DATE	REVISION	BY	APPD
Prelim. Plan By					
Architect/Specialist					



BRIDGE AND STRUCTURES OFFICE

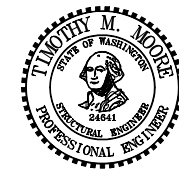

SR 99
ALASKAN WAY VIADUCT - REPLACEMENT
S HOLGATE ST TO S KING ST - PHASE 2
 BRIDGE NO. 99/540 NB & SB
PIER 3N PILE CAP ELEVATION

BRIDGE SHEET NO. BG082
 SHEET 928 OF 1475 SHEETS

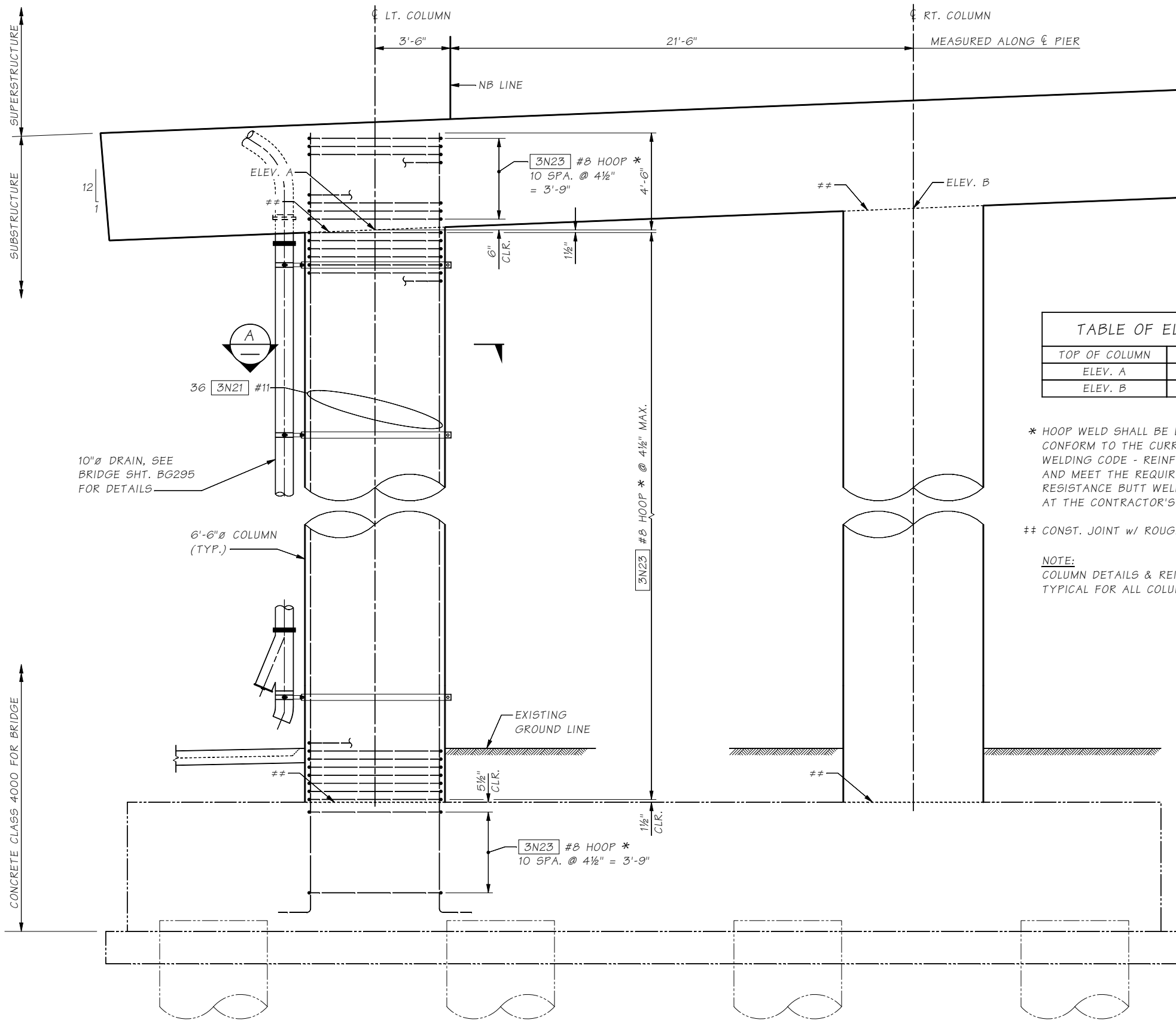
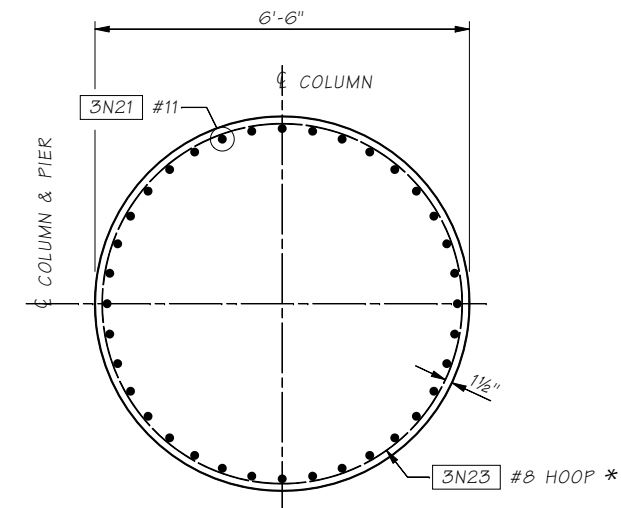

TABLE OF ELEVATIONS	
TOP OF COLUMN	ELEVATION
ELEV. A	43.22
ELEV. B	44.22

* HOOP WELD SHALL BE DIRECT BUTT-WELDED AND CONFORM TO THE CURRENT EDITION OF STRUCTURAL WELDING CODE - REINFORCING STEEL OF AWS(D1.4) AND MEET THE REQUIREMENTS OF STD. SPEC. 6-02.3(24)E. RESISTANCE BUTT WELDED SPLICE MAY BE SUBSTITUTED AT THE CONTRACTOR'S OPTION. SEE SPECIAL PROVISIONS.

** CONST. JOINT W/ ROUGHENED SURFACE

NOTE:
COLUMN DETAILS & REINFORCING TYPICAL FOR ALL COLUMNS.



SECTION A

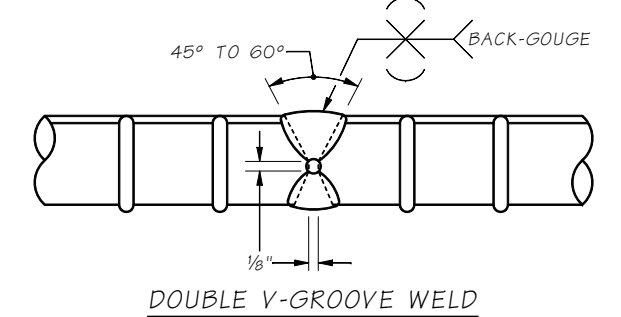
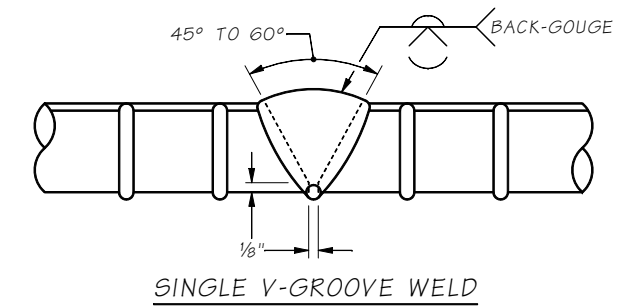

HOOP WELD DETAIL
ALL BACKING SHALL BE REMOVED

COLUMN ELEVATION - PIER 3N

SR 99 FILE NO. SHEET BG083

Bridge Design Engr. Khaleghi, B	M:\Y-Team\AWV SOUTH INTERCHANGE\window files\Pier 3N Col Dtls.WND			
Supervisor Moore, TM	REGION NO.	STATE	FED. AID PROJ. NO.	SHEET NO.
Designed By Lee, CS 09/09	10	WASH.		
Checked By Schultz, E 09/09	JOB NUMBER 09A803			
Detailed By Hanson, CE 09/09				
Bridge Projects Engr.	DATE	REVISION	BY	APPD
Prelim. Plan By				
Architect/Specialist				



BRIDGE AND STRUCTURES OFFICE

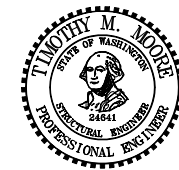

SR 99
ALASKAN WAY VIADUCT - REPLACEMENT
S HOLGATE ST TO S KING ST - PHASE 2
BRIDGE NO. 99/540 NB & SB
PIER 3N COLUMN DETAILS

BRIDGE SHEET NO. BG083
SHEET 929 OF 1475 SHEETS

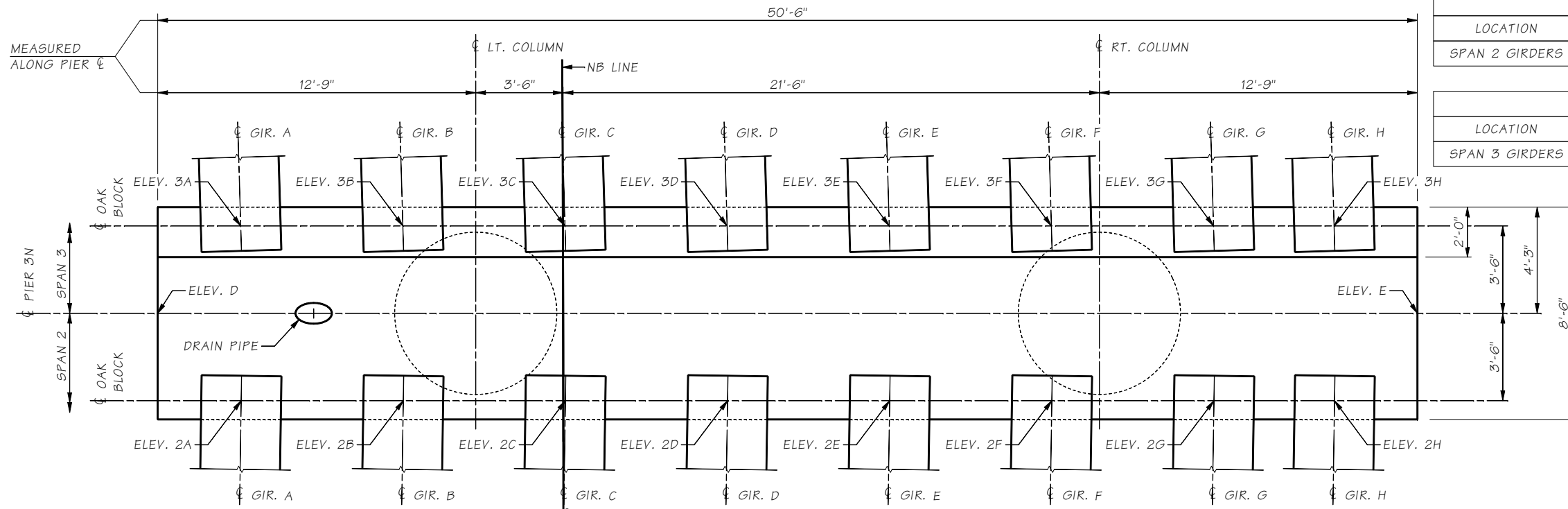

PLAN

LOCATION	2A	2B	2C	2D	2E	2F	2G	2H
SPAN 2 GIRDERS	48.13	48.39	48.65	48.91	49.17	49.43	49.69	49.89

LOCATION	3A	3B	3C	3D	3E	3F	3G	3H
SPAN 3 GIRDERS	48.37	48.63	48.89	49.15	49.41	49.67	49.93	50.12

LOCATION	ELEVATION
D	47.71
E	49.73
F	55.13
G	57.13

NOTE:
SEE FRAMING PLAN FOR GIRDER SPACING.

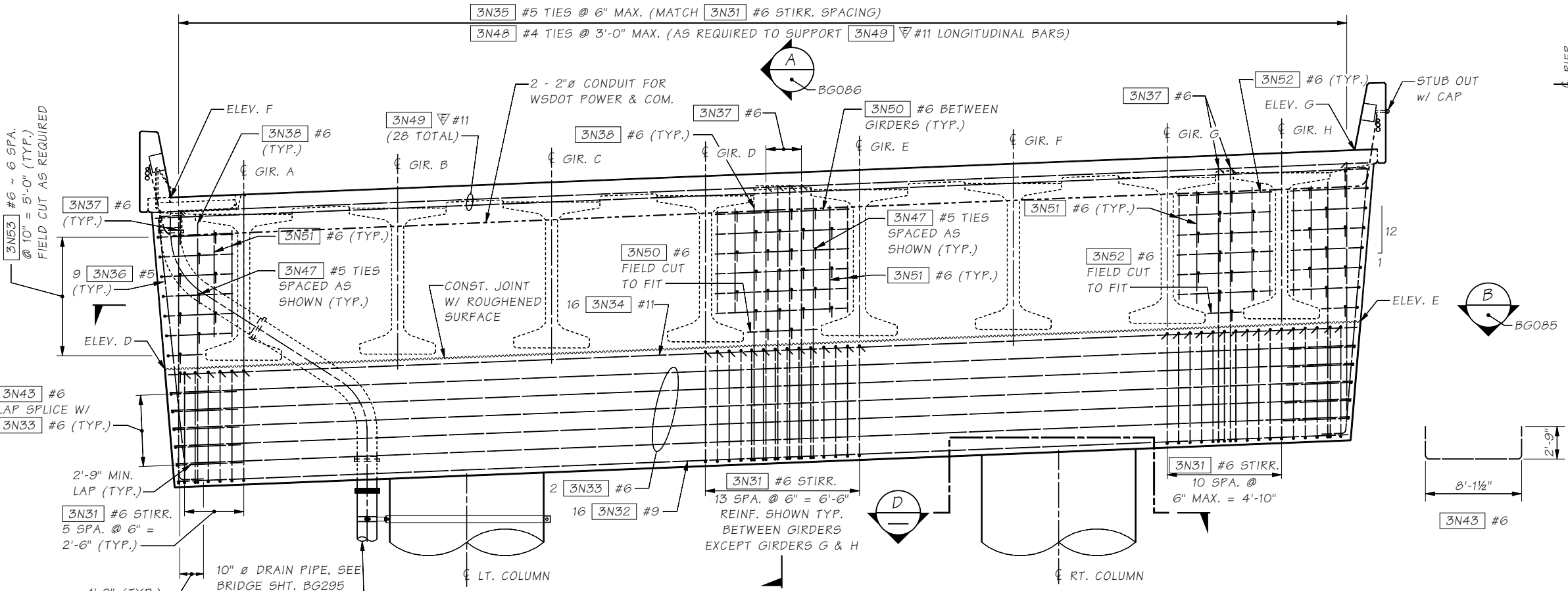

ELEVATION

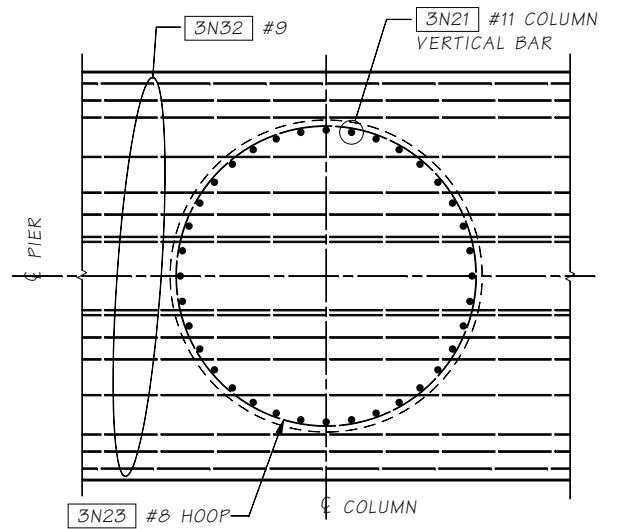

SECTION D

TRANSVERSE REINFORCING NOT SHOWN FOR CLARITY. ADJUST LONGITUDINAL BAR, TRANSVERSE STIRRUP, AND THE TIE SPACING AS REQUIRED TO CLEAR COLUMN VERTICAL BARS.

- NOTES:
1. SLAB REINFORCING NOT SHOWN FOR CLARITY.
 2. ADJUST STIRRUP AND TIE SPACING AS REQUIRED TO CLEAR COLUMN VERTICAL BARS.
 3. DIAPHRAGM REINFORCING SHOWN FOR SPAN 2 FACE ONLY. SEE SECTION B FOR DETAILS.

SR 99 FILE NO. SHEET BG084

Bridge Design Engr. Khaleghi, B	M:\Y-Team\AWV SOUTH INTERCHANGE\window files\Pier 3N X-Beam Plan-Elev.WND		
Supervisor Moore, TM	REGION NO.	STATE	FED. AID PROJ. NO.
Designed By Lee, CS 09/08	10	WASH.	
Checked By Glassford, P 09/09	JOB NUMBER	09A803	
Detailed By Lemcke, DR 05/09	DATE	REVISION	BY APPD
Bridge Projects Engr.			
Prelim. Plan By			
Architect/Specialist			



BRIDGE AND STRUCTURES OFFICE

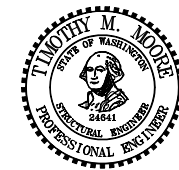

SR 99
ALASKAN WAY VIADUCT - REPLACEMENT
S HOLGATE ST TO S KING ST - PHASE 2
BRIDGE NO. 99/540 NB & SB
PIER 3N CROSSBEAM
PLAN AND ELEVATION

BRIDGE SHEET NO. BG084
SHEET 930 OF 1475 SHEETS

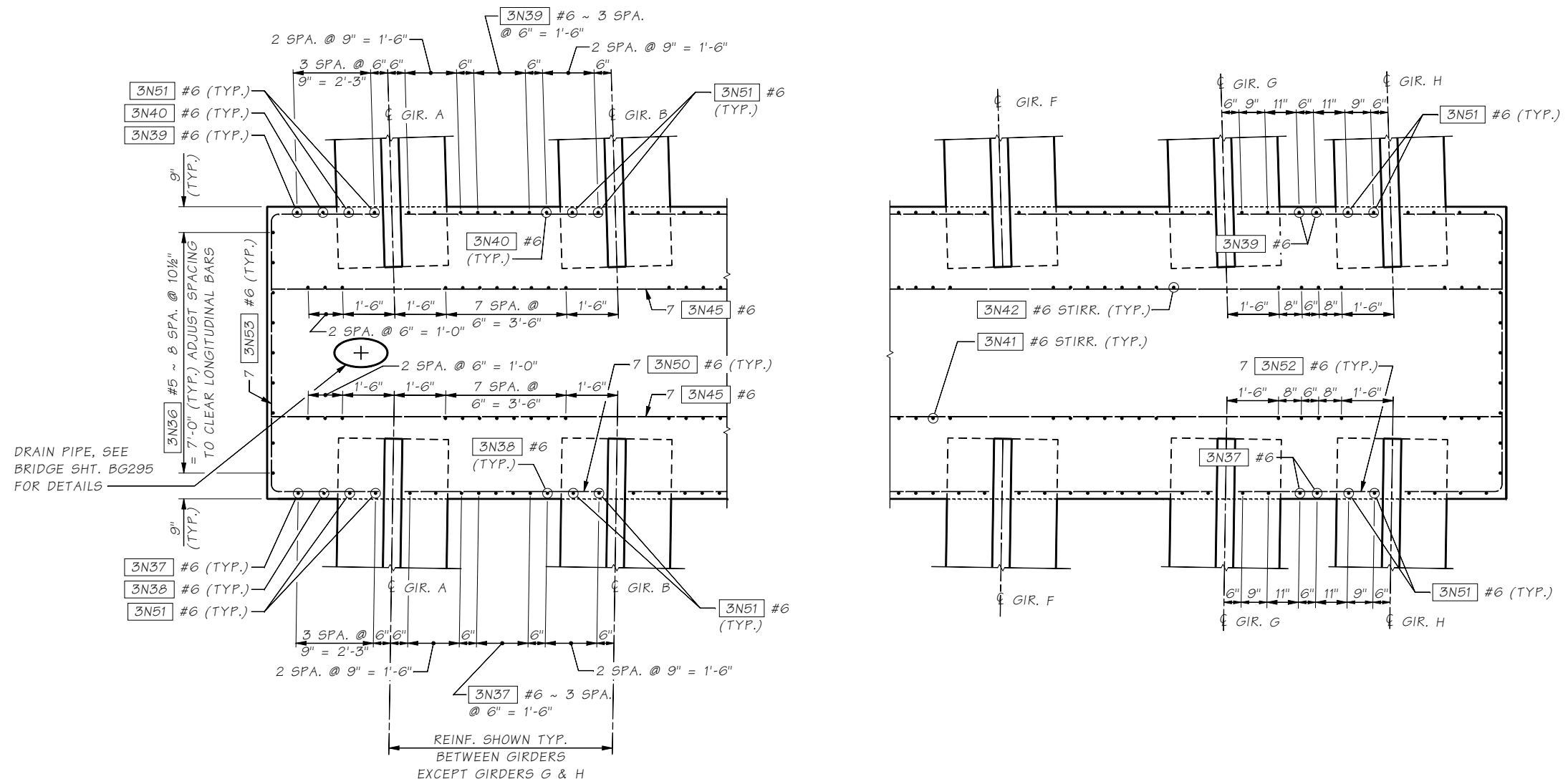

SECTION B
BG084

Bridge Design Engr.	Khaleghi, B	M:\Y-Team\AWV SOUTH INTERCHANGE\window files\Pier 3N X-Beam Dtls.WND			
Supervisor	Moore, TM	REGION NO.	STATE	FED. AID PROJ. NO.	SHEET NO.
Designed By	Lee, CS	10	WASH.		TOTAL SHEETS
Checked By	Glassford, P	JOB NUMBER			
Detailed By	Hanson, CE	09A803			
Bridge Projects Engr.		DATE	REVISION	BY	APPD
Prelim. Plan By					
Architect/Specialist					



BRIDGE
AND
STRUCTURES
OFFICE

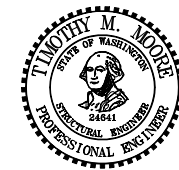

SR 99
ALASKAN WAY VIADUCT - REPLACEMENT
S HOLGATE ST TO S KING ST - PHASE 2
BRIDGE NO. 99/540 NB & SB
PIER 3N CROSSBEAM DETAILS 1 OF 2

BRIDGE SHEET NO. BG085
SHEET 931 OF 1475 SHEETS

SR 99 FILE NO. SHEET BG086

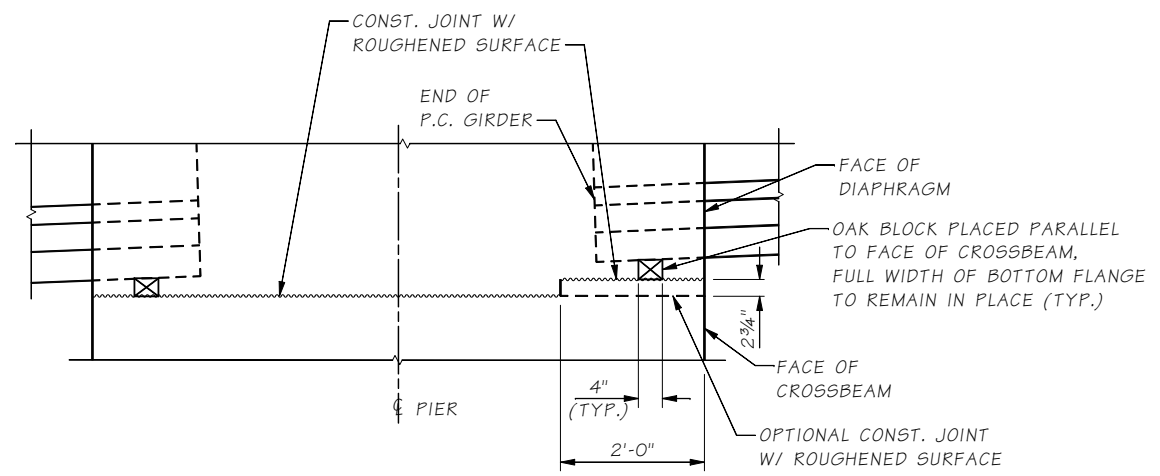

OAK BLOCK DETAIL
LONGITUDINAL DIMENSIONS ARE NORMAL TO SKEW

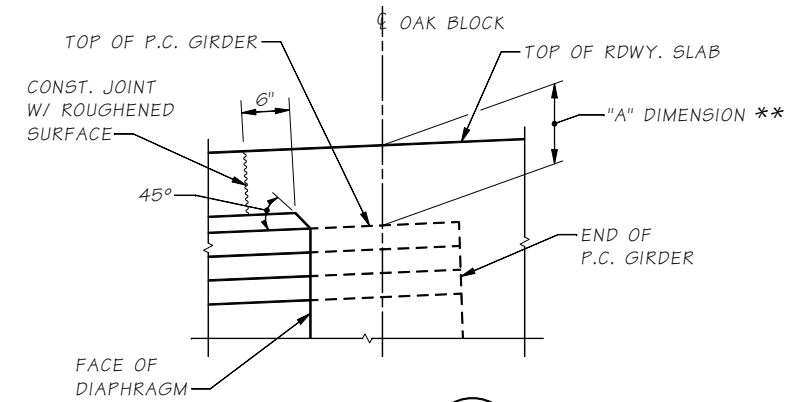

DETAIL C
REINFORCING NOT SHOWN FOR CLARITY

** SEE "GIRDER SCHEDULE" SHEETS

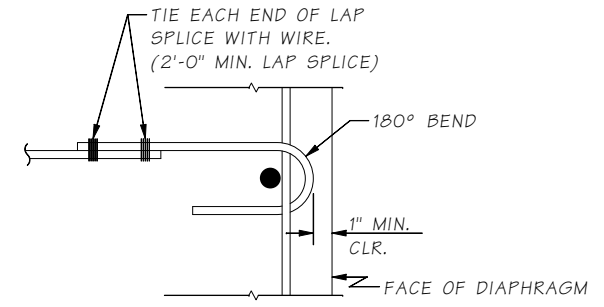

TIE BAR DETAIL

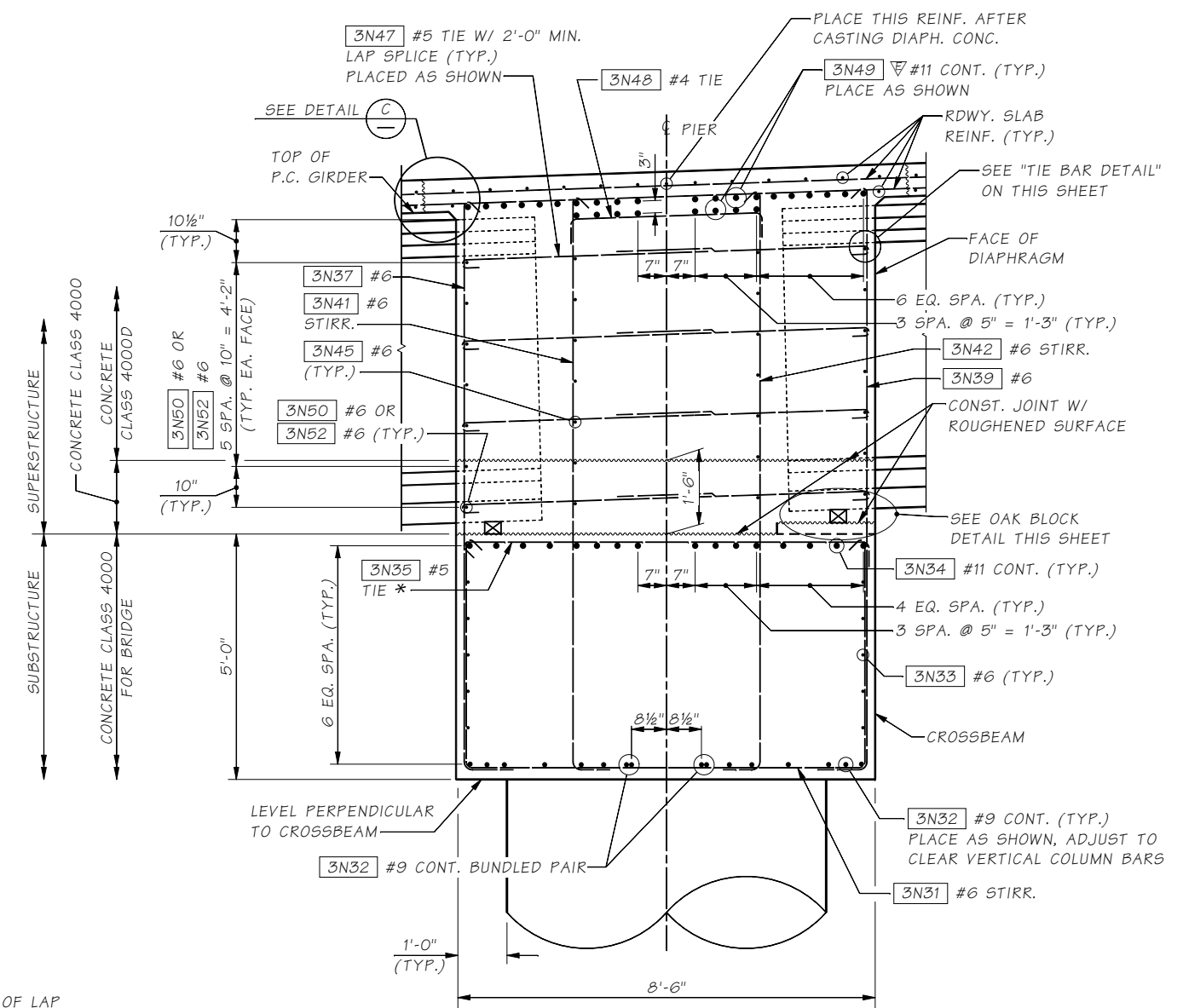

* ALTERNATE 135° HOOK EVERY OTHER BAR

SECTION A
BG084

- NOTES:**
1. LONGITUDINAL DIMENSIONS ARE NORMAL TO SKEW.
 2. FOR CONCRETE PLACEMENT PROCEDURE, SEE "CONSTRUCTION SEQUENCE" SHEET.

Bridge Design Engr.	Khaleghi, B	M:\Y-Team\AWV SOUTH INTERCHANGE\window files\Pier 3N X-Beam Dtls 2.WND			
Supervisor	Moore, TM	REGION NO.	STATE	FED. AID PROJ. NO.	SHEET NO.
Designed By	Lee, CS	10	WASH.		TOTAL SHEETS
Checked By	Glassford, P	JOB NUMBER 09A803			
Detailed By	Lemcke, DR				
Bridge Projects Engr.					
Prelim. Plan By					
Architect/Specialist		DATE	REVISION	BY	APPD



BRIDGE AND STRUCTURES OFFICE

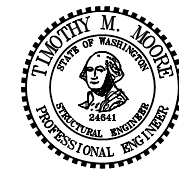

SR 99
ALASKAN WAY VIADUCT - REPLACEMENT
S HOLGATE ST TO S KING ST - PHASE 2
BRIDGE NO. 99/540 NB & SB

BRIDGE SHEET NO.
BG086
SHEET
932
OF
1475
SHEETS

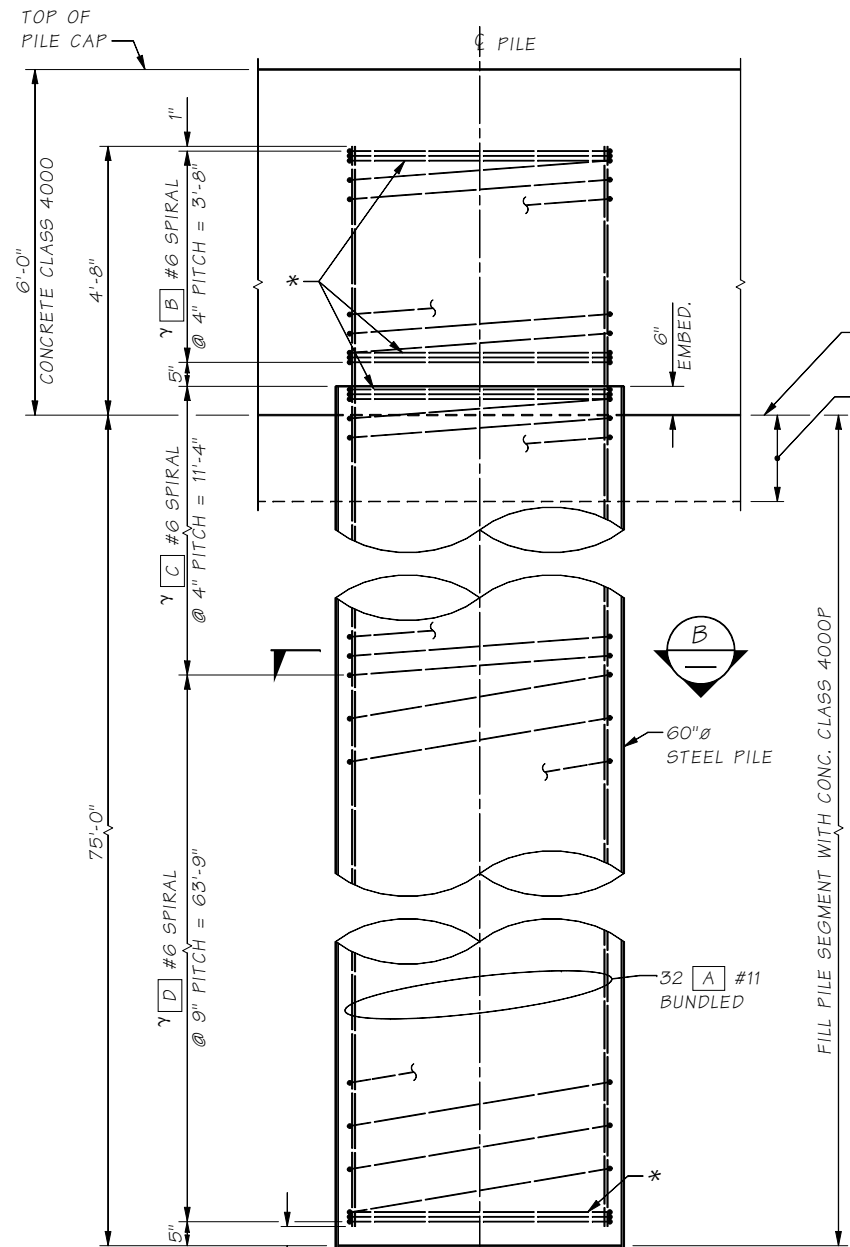

* SEE SPIRAL TERMINATION DETAIL ON THIS SHEET.

γ WELDED SPLICE ONLY (SEE WELDED LAP SPLICE DETAIL ON THIS SHEET)

FIELD SPLICE LOCATION (PER CONTRACTOR) FOR FIT UP SEE DETAIL W

MIN. TIP ELEVATION SEE SPECIAL PROVISIONS

OPEN END WITH CUTTING SHOE, SEE "PILE TIP DETAIL" ON THIS SHEET

TYPICAL PILE ELEVATION

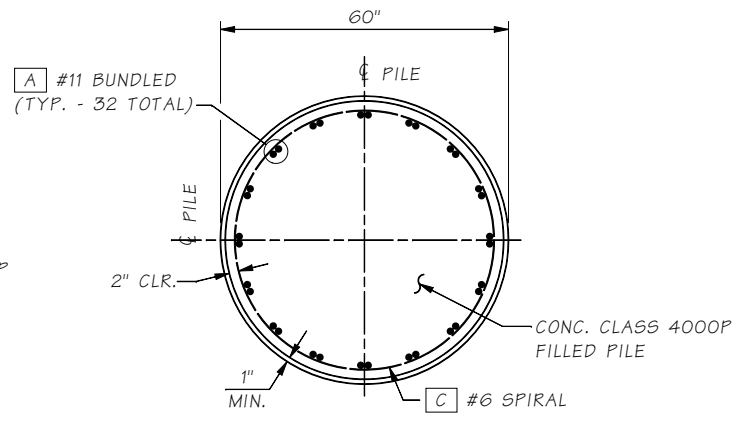

SECTION B

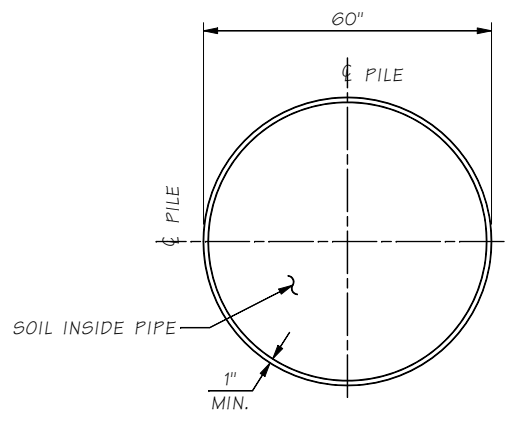

SECTION A

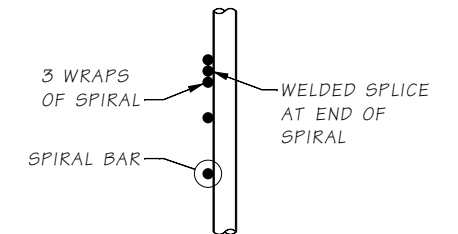

SPIRAL TERMINATION DETAIL

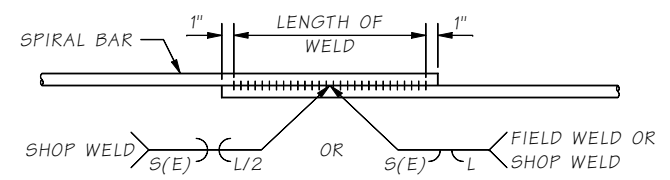

WELDED LAP SPLICE DETAIL

WELDING SHALL MEET THE REQUIREMENTS OF STD. SPEC. 6-02.3(24)E FOR WELD DIMENSIONS, SEE TABLE BELOW.

DEFORMED BAR	WELD DIMENSIONS		
	S	E	LENGTH (L)
#6	3/8	3/16	6"

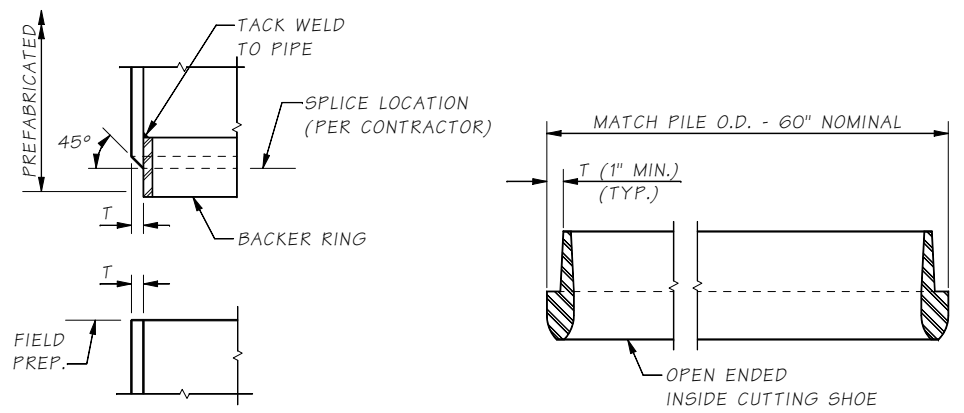

DETAIL W

PERMISSIBLE WELD SPLICE DETAILS FOR STEEL PIPE PILES. SEE "100% U.T. INSPECTION LIMITS" ON BR. SHT. BGO67 FOR WELDING INSPECTION REQUIREMENTS.

PILE TIP DETAIL

STEEL PILE WALL THICKNESS (T) AND CUTTING SHOE THICKNESS SHALL BE DETERMINED BY CONTRACTOR. SEE STD. SPEC. 6-05.3(B)

PILE BAR LIST

ALL REINFORCING SHALL BE ASTM A 706

PIER	PILES REQUIRED PER PIER	MARK	BAR SIZE	BARS PER PILE	LENGTH	BEND TYPE	WT. (LBS.) PER PILE
4N	8	A	#11	32	79'-4"	STRAIGHT	13,489
		B	#6	1	(a)	SPIRAL	324
		C	#6	1	(a)	SPIRAL	777
		D	#6	1	(a)	SPIRAL	1,879
TOTAL							16,469

(a) ~ DETERMINED FROM PLANS



SPIRAL WEIGHT INCLUDES SPLICES

SR 99 FILE NO. SHEET BG087

Bridge Design Engr. Khaleghi, B	M:\Y-Team\AWV SOUTH INTERCHANGE\window files\Pier 4N Pile Dtls.WND			
Supervisor Moore, TM	REGION NO.	STATE	FED. AID PROJ. NO.	SHEET NO.
Designed By Schultz, E 09/09	10	WASH.		
Checked By Lee, CS 09/09	JOB NUMBER 09A803			
Detailed By Hanson, CE 09/09				
Bridge Projects Engr.	DATE	REVISION	BY	APPD
Prelim. Plan By				
Architect/Specialist				



BRIDGE AND STRUCTURES OFFICE

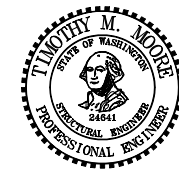

SR 99
ALASKAN WAY VIADUCT - REPLACEMENT
S HOLGATE ST TO S KING ST - PHASE 2
BRIDGE NO. 99/540 NB & SB
PIER 4N PILE DETAILS

BRIDGE SHEET NO. BG087
SHEET 933 OF 1475 SHEETS

SR 99 FILE NO. SHEET BG088

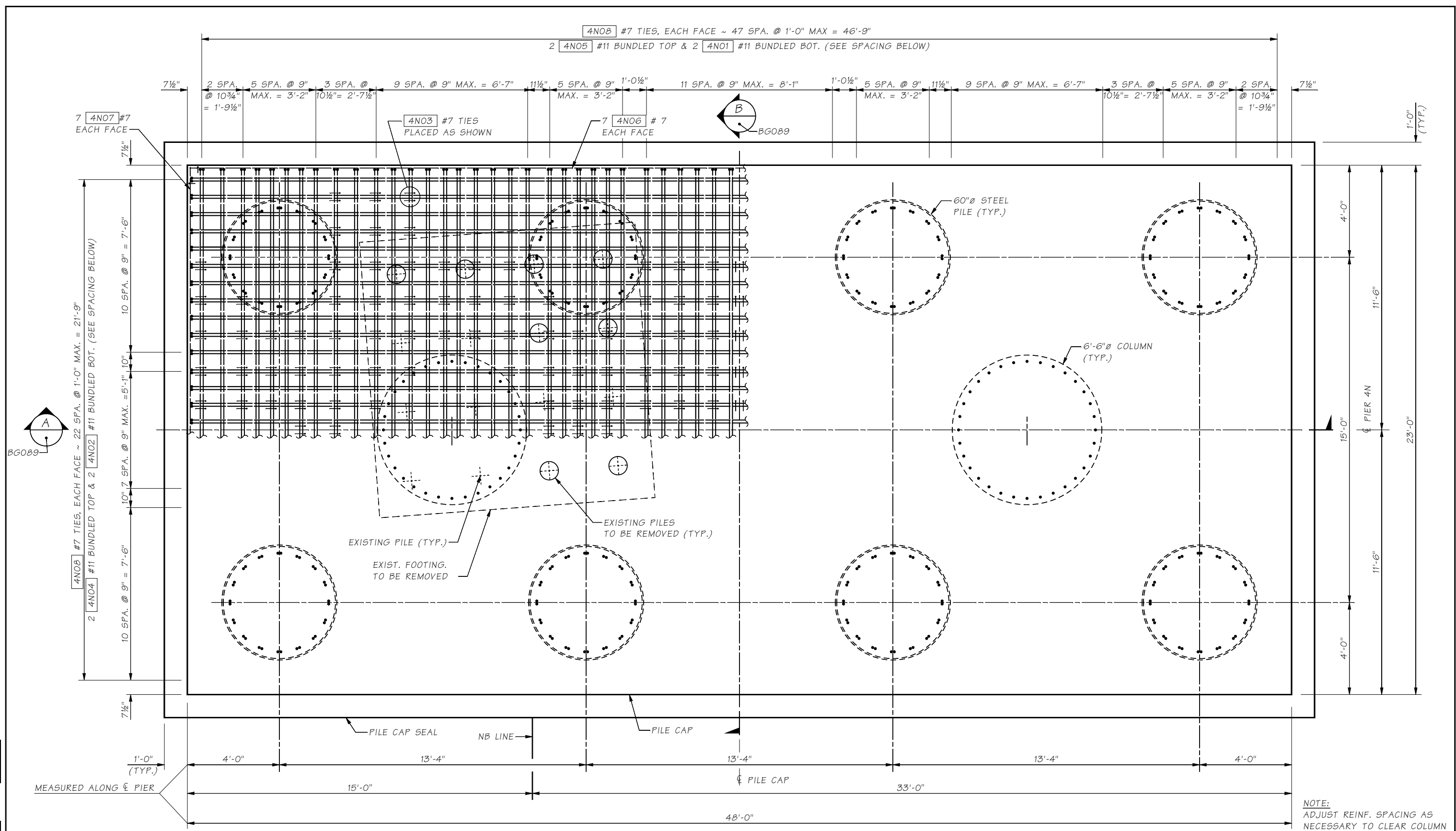

PLAN

NOTE:
ADJUST REINF. SPACING AS NECESSARY TO CLEAR COLUMN AND PILE VERTICAL BARS.

Bridge Design Engr.	Khaleghi, B	M:\Y-Team\AWV SOUTH INTERCHANGE\window files\Pier 4N Pile Cap Plan.WND			
Supervisor	Moore, TM	REGION NO.	STATE	FED. AID PROJ. NO.	SHEET NO.
Designed By	Schultz, E 09/09	10	WASH.		TOTAL SHEETS
Checked By	Lee, CS 09/09	JOB NUMBER 09A803			
Detailed By	Hanson, CE 09/09				
Bridge Projects Engr.		DATE	REVISION	BY	APPD
Prelim. Plan By		2/17/10	REVISED SHEET	CSL	TMM
Architect/Specialist					



BRIDGE AND STRUCTURES OFFICE

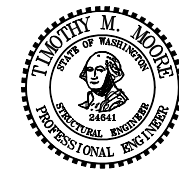

SR 99
ALASKAN WAY VIADUCT - REPLACEMENT
S HOLGATE ST TO S KING ST - PHASE 2
BRIDGE NO. 99/540 NB & SB

PIER 4N PILE CAP PLAN

BRIDGE SHEET NO. BG088
SHEET 934 OF 1475 SHEETS

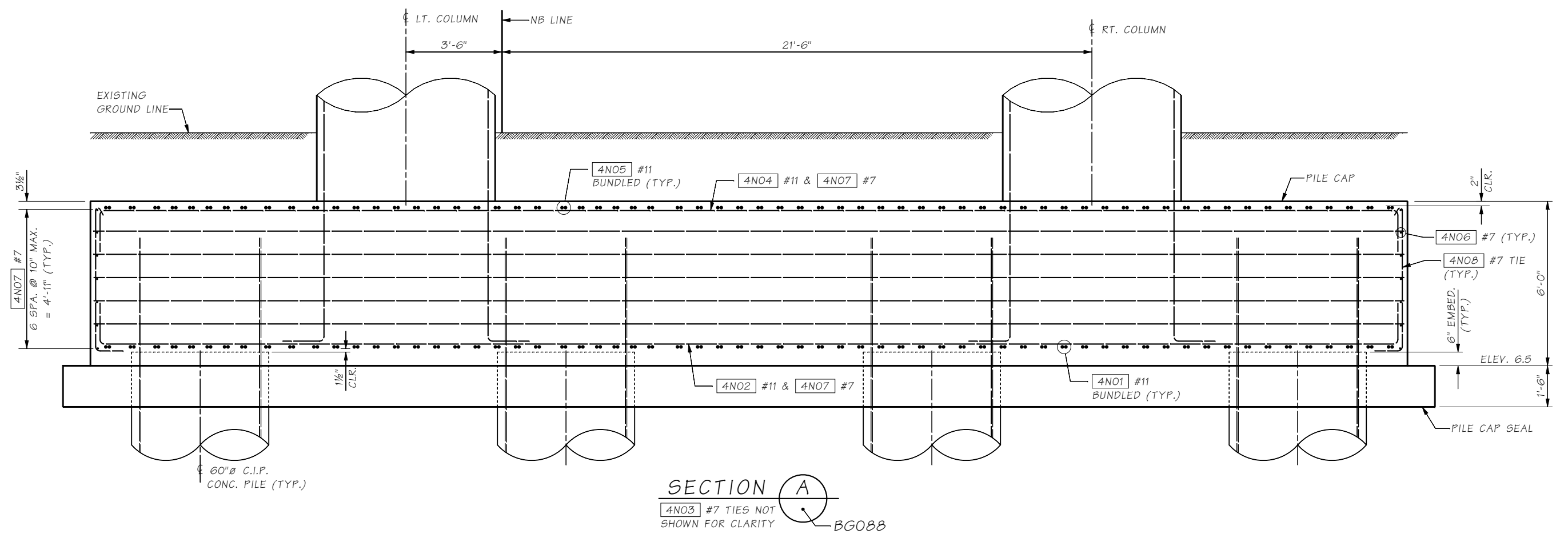
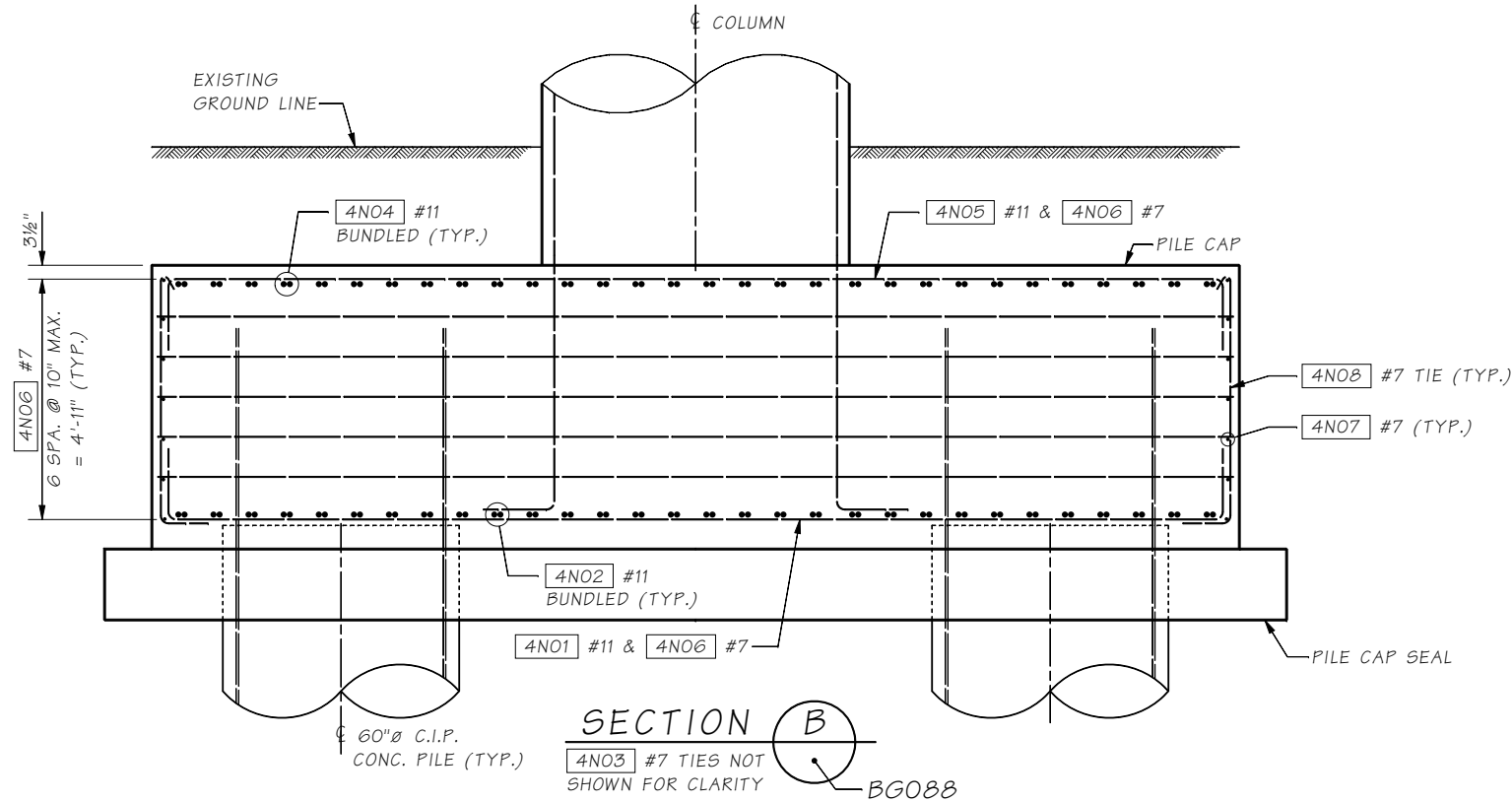

SR 99 FILE NO. SHEET BG089

Bridge Design Engr.	Khaleghi, B	M:\Y-Team\AW SOUTH INTERCHANGE\window files\Pier 4N Pile Cap Elev.WND			
Supervisor	Moore, TM	REGION NO.	STATE	FED. AID PROJ. NO.	SHEET NO.
Designed By	Schultz, E 09/09	10	WASH.		TOTAL SHEETS
Checked By	Lee, CS 09/09	JOB NUMBER 09A803			
Detailed By	Hanson, CE 09/09				
Bridge Projects Engr.		DATE	REVISION	BY	APPD
Prelim. Plan By					
Architect/Specialist					



BRIDGE AND STRUCTURES OFFICE

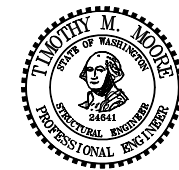

SR 99
ALASKAN WAY VIADUCT - REPLACEMENT
S HOLGATE ST TO S KING ST - PHASE 2
BRIDGE NO. 99/540 NB & SB
PIER 4N PILE CAP ELEVATION

BRIDGE SHEET NO. BG089
SHEET 935 OF 1475 SHEETS

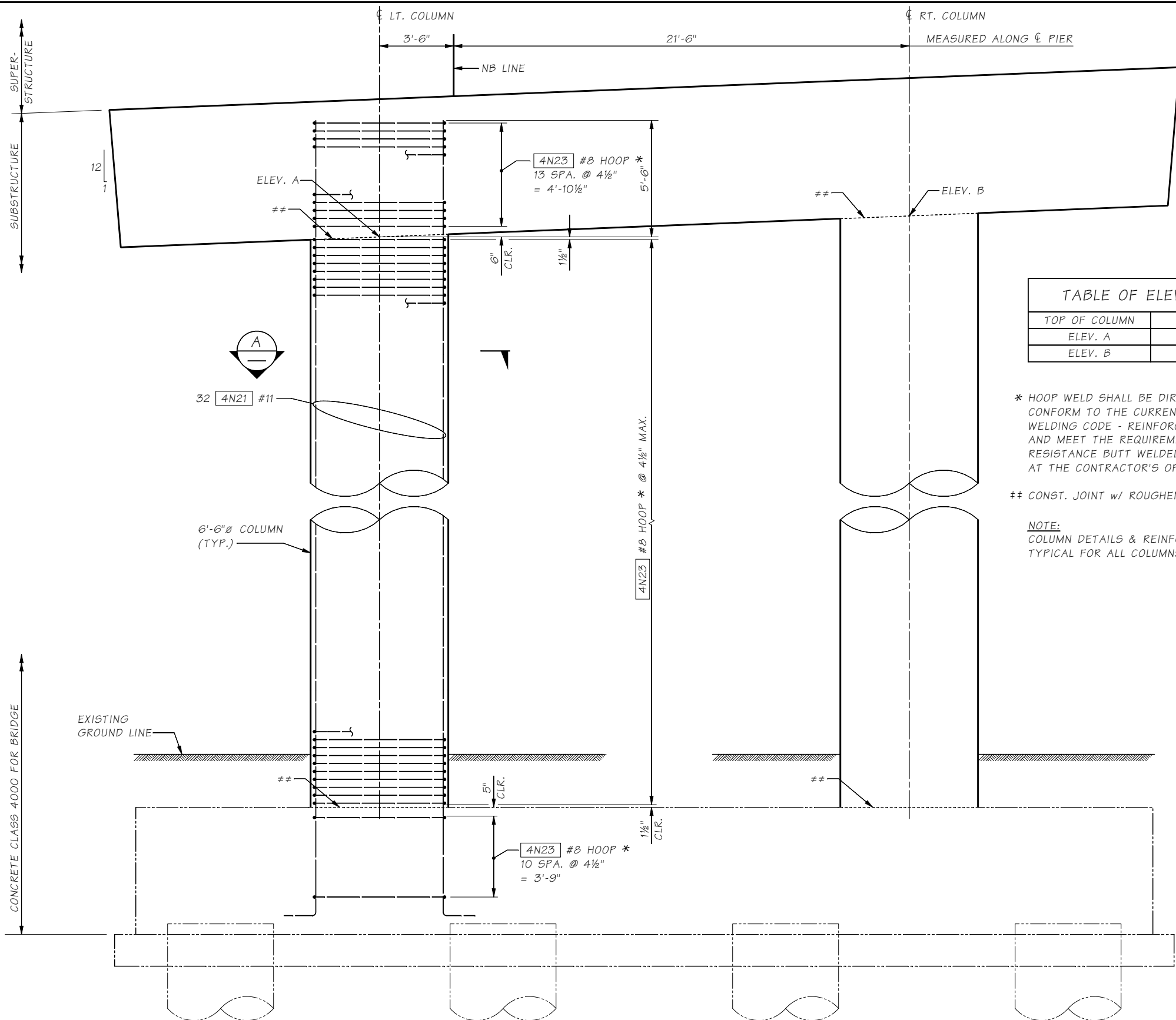
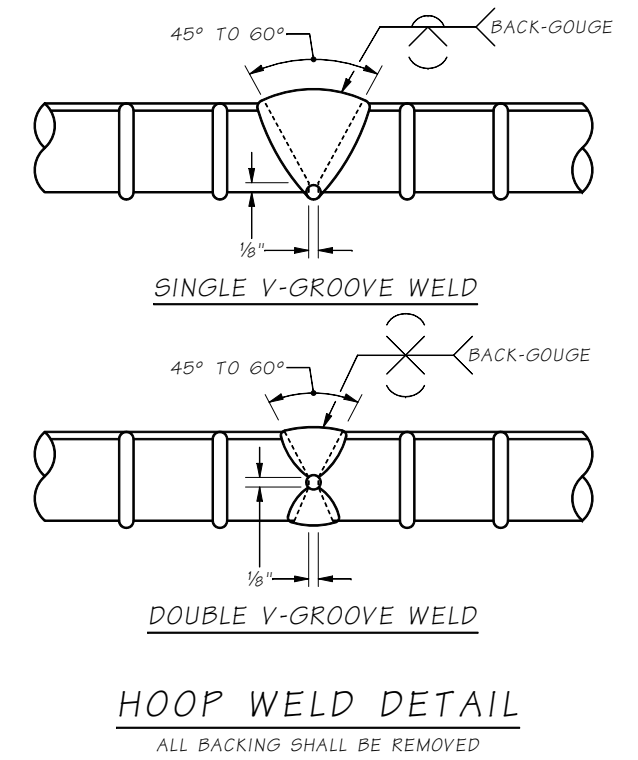
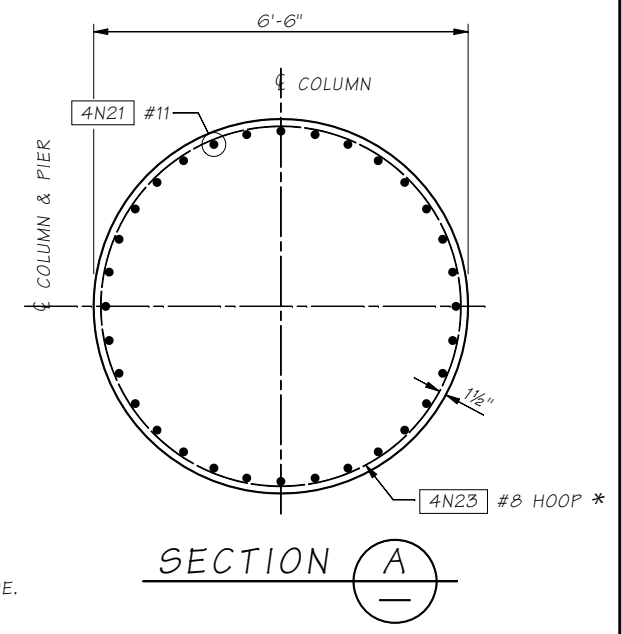

TABLE OF ELEVATIONS	
TOP OF COLUMN	ELEVATION
ELEV. A	46.02
ELEV. B	47.02

* HOOP WELD SHALL BE DIRECT BUTT-WELDED AND CONFORM TO THE CURRENT EDITION OF STRUCTURAL WELDING CODE - REINFORCING STEEL OF AWS(D1.4) AND MEET THE REQUIREMENTS OF STD. SPEC. 6-02.3(24)E. RESISTANCE BUTT WELDED SPLICE MAY BE SUBSTITUTED AT THE CONTRACTOR'S OPTION. SEE SPECIAL PROVISIONS.

CONST. JOINT w/ ROUGHENED SURFACE

NOTE:
COLUMN DETAILS & REINFORCING
TYPICAL FOR ALL COLUMNS.



COLUMN ELEVATION - PIER 4N

SR 99 FILE NO. SHEET BG090

Bridge Design Engr. Khaleghi, B	M:\Y-Team\AWV SOUTH INTERCHANGE\window files\Pier 4N Col Dtls.WND			
Supervisor Moore, TM	REGION NO.	STATE	FED. AID PROJ. NO.	SHEET TOTAL
Designed By Lee, CS 09/09	10	WASH.		
Checked By Schultz, E 09/09	JOB NUMBER 09A803			
Detailed By Hanson, CE 09/09				
Bridge Projects Engr.	DATE	REVISION	BY	APPD
Prelim. Plan By				
Architect/Specialist				



BRIDGE AND STRUCTURES OFFICE



SR 99
ALASKAN WAY VIADUCT - REPLACEMENT
S HOLGATE ST TO S KING ST - PHASE 2
BRIDGE NO. 99/540 NB & SB
PIER 4N COLUMN DETAILS

BRIDGE SHEET NO. BG090
SHEET 936 OF 1475 SHEETS

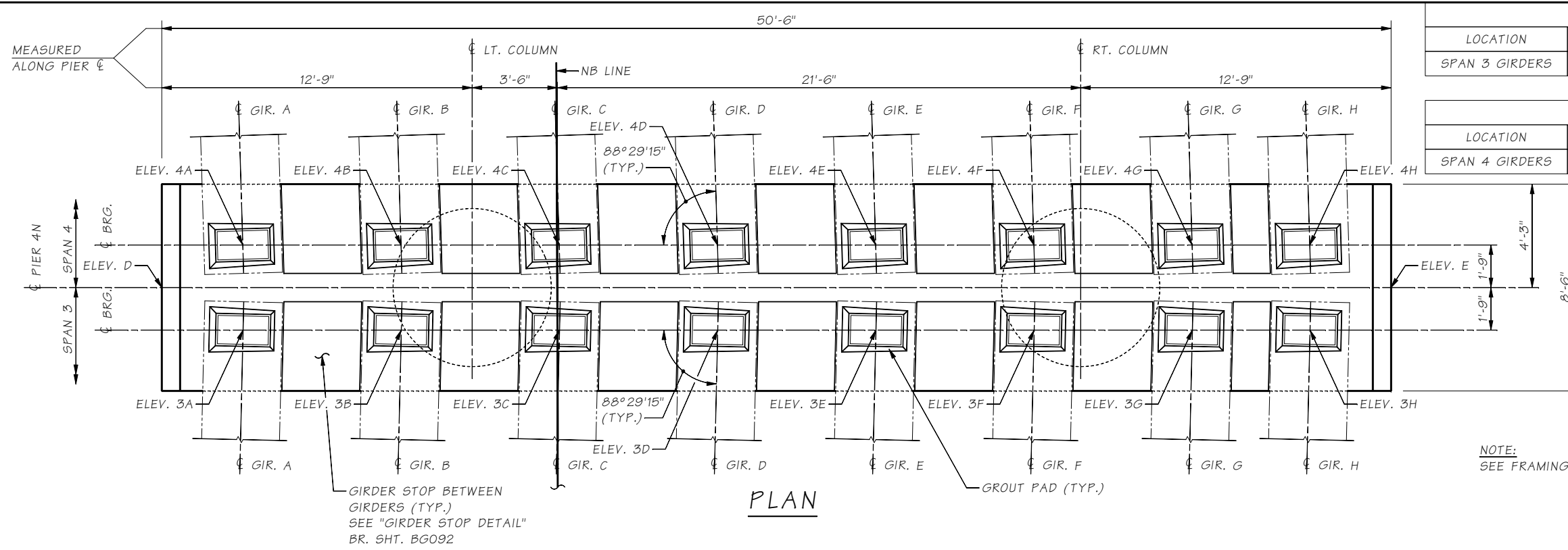

LOCATION	3A	3B	3C	3D	3E	3F	3G	3H
SPAN 3 GIRDERS	52.27	52.53	52.79	53.05	53.31	53.57	53.83	54.02

LOCATION	4A	4B	4C	4D	4E	4F	4G	4H
SPAN 4 GIRDERS	52.34	52.60	52.86	53.12	53.38	53.64	53.90	54.09

LOCATION	ELEVATION
D	52.01
E	54.03
F	59.52
G	61.52

NOTE:
SEE FRAMING PLAN FOR GIRDER SPACING.

PLAN

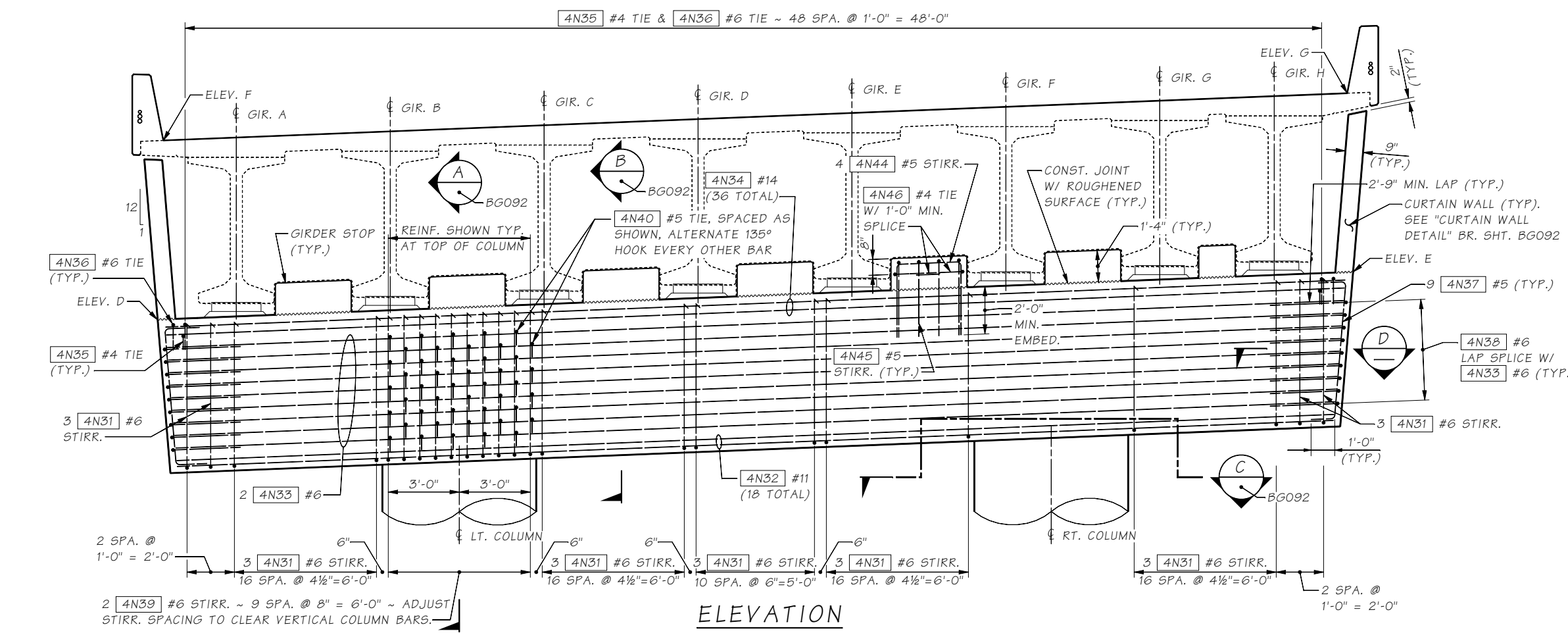

ELEVATION

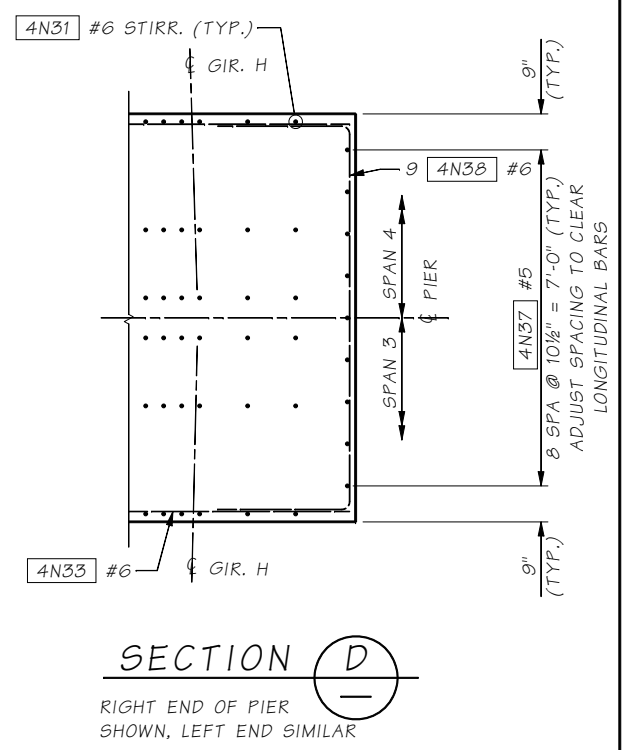

SECTION D
RIGHT END OF PIER SHOWN, LEFT END SIMILAR

SR 99 FILE NO. SHEET BG091

Bridge Design Engr. Khaleghi, B	M:\Y-Team\AWV SOUTH INTERCHANGE\Window files\Pier 4N X-Beam Plan-Elev.WND			
Supervisor Moore, TM	REGION NO.	STATE	FED. AID PROJ. NO.	SHEET NO.
Designed By Lee, CS 09/08	10	WASH.		TOTAL SHEETS
Checked By Glassford, P 09/09	JOB NUMBER 09A803			
Detailed By Hanson, CE 09/08				
Bridge Projects Engr.	DATE	REVISION	BY	APPD
Prelim. Plan By				
Architect/Specialist				



BRIDGE AND STRUCTURES OFFICE



SR 99
ALASKAN WAY VIADUCT - REPLACEMENT
S HOLGATE ST TO S KING ST - PHASE 2
BRIDGE NO. 99/540 NB & SB

PIER 4N CROSSBEAM
PLAN AND ELEVATION

BRIDGE SHEET NO. BG091
SHEET 937 OF 1475 SHEETS

SR 99 FILE NO. SHEET BG092

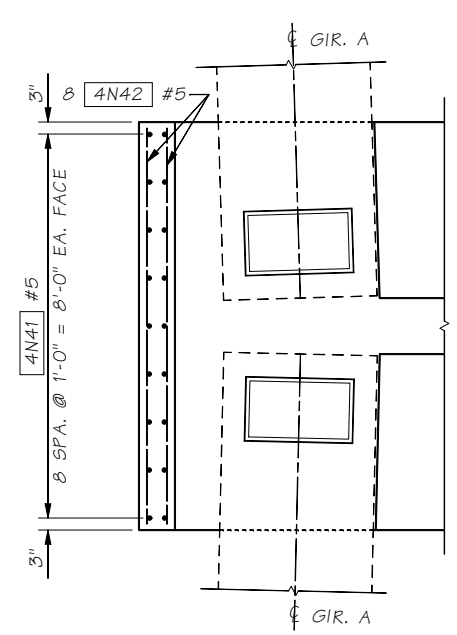

SECTION E

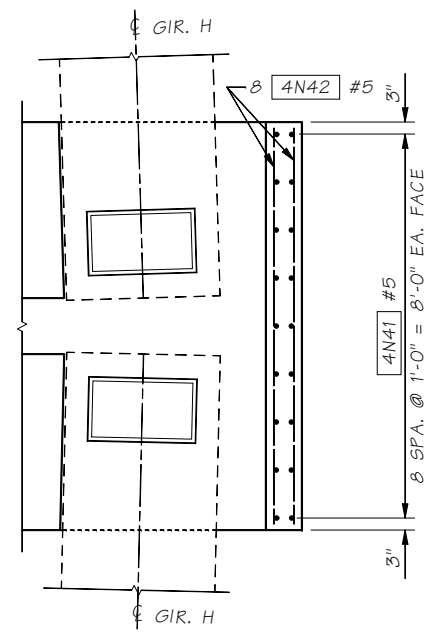

SECTION D

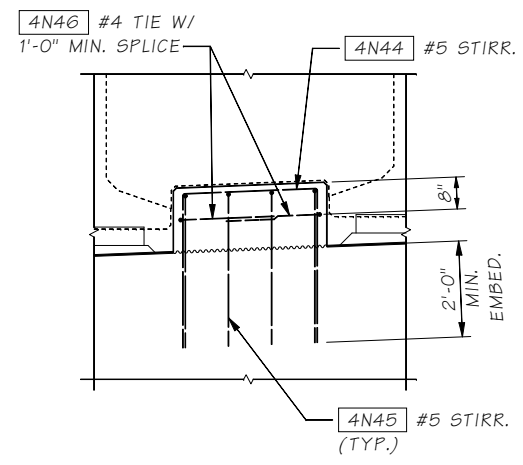

SECTION F

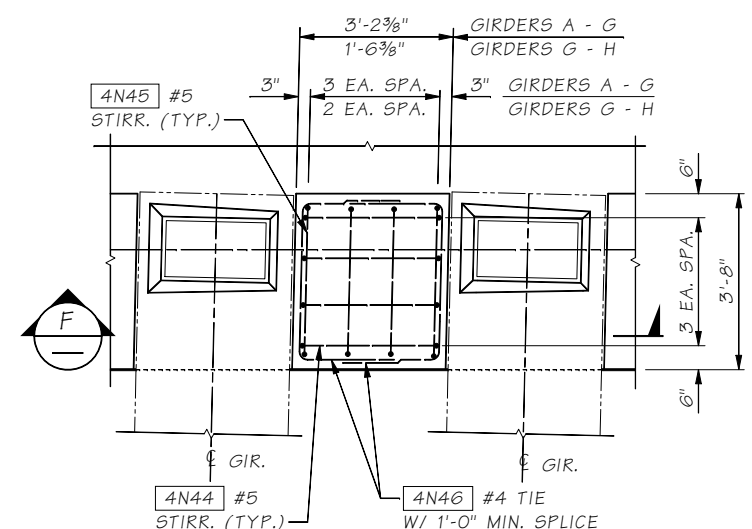

GIRDER STOP DETAIL

NOTE:
SEE "GIRDER SEAT DETAIL" BR. SHT. BG144
FOR ADDITIONAL INFORMATION.

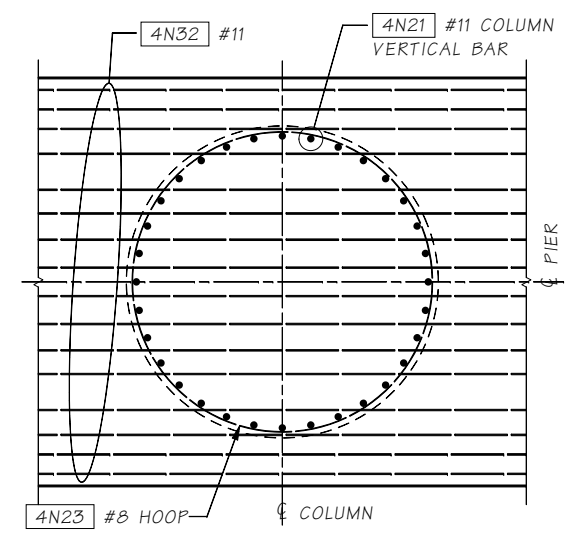

SECTION C

TRANSVERSE REINFORCING
NOT SHOWN FOR CLARITY.
ADJUST LONGITUDINAL BAR,
TRANSVERSE STIRRUP, AND THE TIE SPACING
AS REQUIRED TO CLEAR COLUMN VERTICAL BARS.

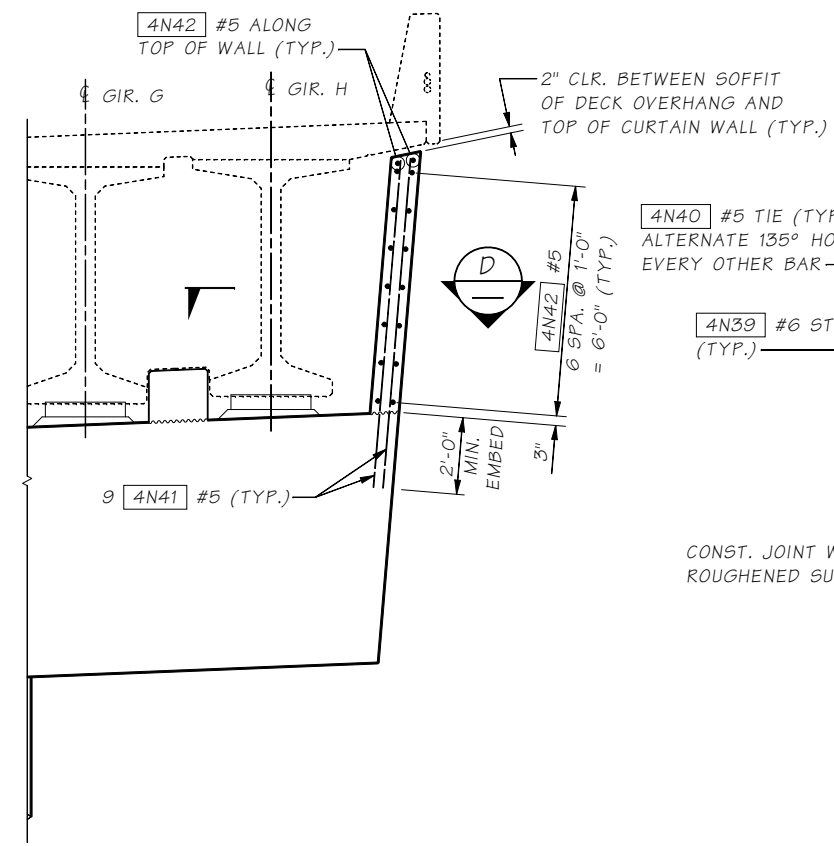
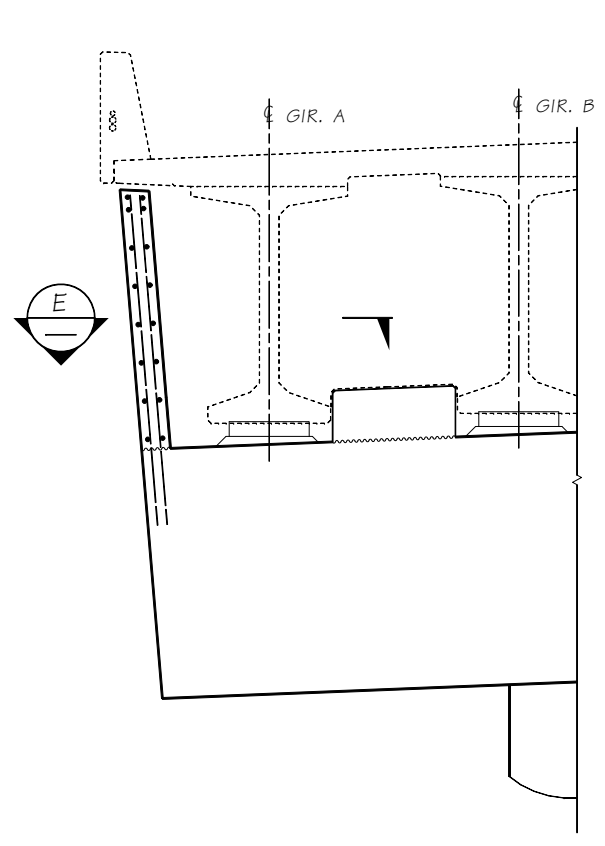

CURTAIN WALL DETAIL

CROSSBEAM REINFORCING NOT SHOWN FOR CLARITY

4N40 #5 TIE (TYP.)
ALTERNATE 135° HOOK
EVERY OTHER BAR

4N39 #6 STIRR.
(TYP.)

CONST. JOINT W/
ROUGHENED SURFACE

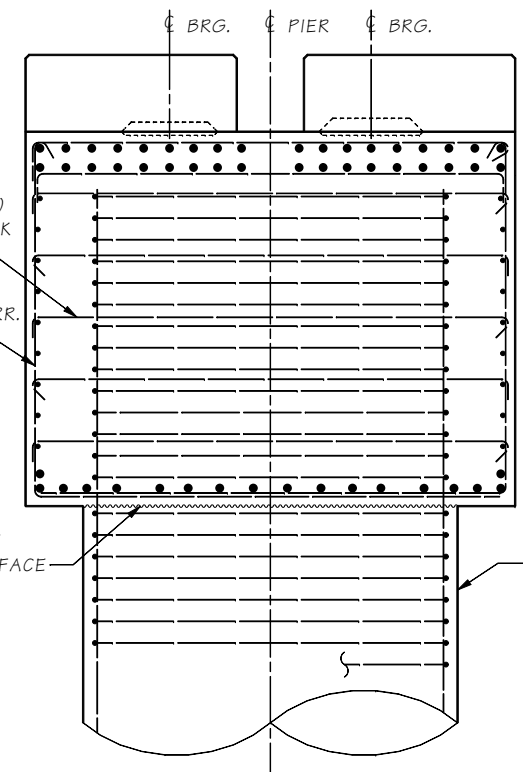

SECTION A

NOTE:
FOR DETAILS NOT
SHOWN SEE SECTION B

GIRDER STOP (TYP.)
SEE "GIRDER STOP
DETAIL" THIS SHEET

4N36 #6 TIE
ALTERNATE 135°
HOOK EVERY
OTHER BAR

4N35 #4 TIE

4N33 #6 (TYP.)

4N31 #6 STIRR.
(TYP.)

LEVEL PERPENDICULAR
TO CROSSBEAM

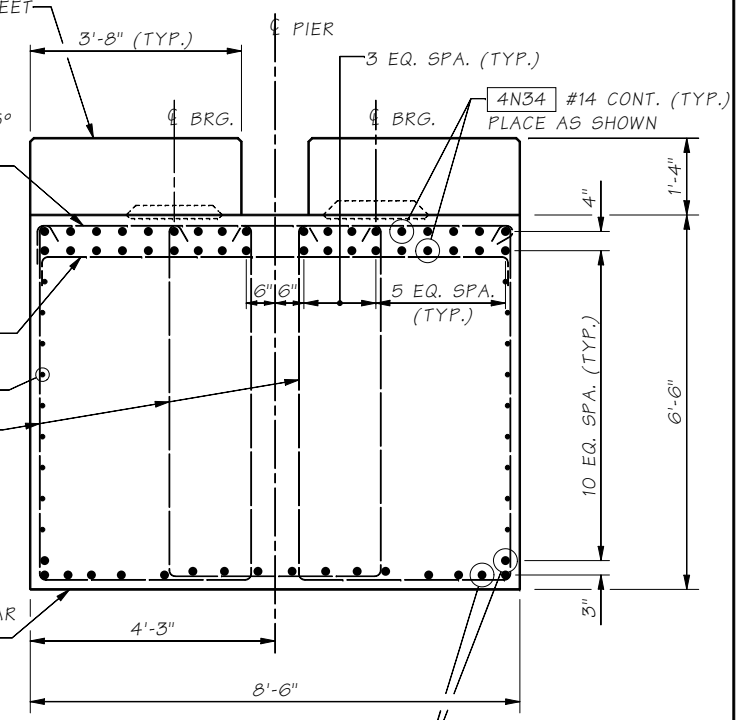

SECTION B

NOTE:
LONGITUDINAL DIMENSIONS
ARE NORMAL TO SKEW.

4N32 #11 CONT. (TYP.)
PLACE AS SHOWN. ADJUST TO
CLEAR VERTICAL COLUMN BARS.

Bridge Design Engr.	Khaleghi, B	M:\Y-Team\AWV SOUTH INTERCHANGE\window files\Pier 4N X-Beam Dtls.WND			
Supervisor	Moore, TM	REGION NO.	STATE	FED. AID PROJ. NO.	SHEET NO.
Designed By	Lee, CS	10	WASH.		TOTAL SHEETS
Checked By	Glassford, P	JOB NUMBER 09A803			
Detailed By	Hanson, CE				
Bridge Projects Engr.					
Prelim. Plan By					
Architect/Specialist		DATE	REVISION	BY	APPD



BRIDGE AND STRUCTURES OFFICE

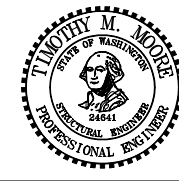

SR 99
ALASKAN WAY VIADUCT - REPLACEMENT
S HOLGATE ST TO S KING ST - PHASE 2
BRIDGE NO. 99/540 NB & SB
PIER 4N CROSSBEAM DETAILS

BRIDGE SHEET NO. BG092
SHEET 938 OF 1475 SHEETS

SR 99 FILE NO. SHEET BG093

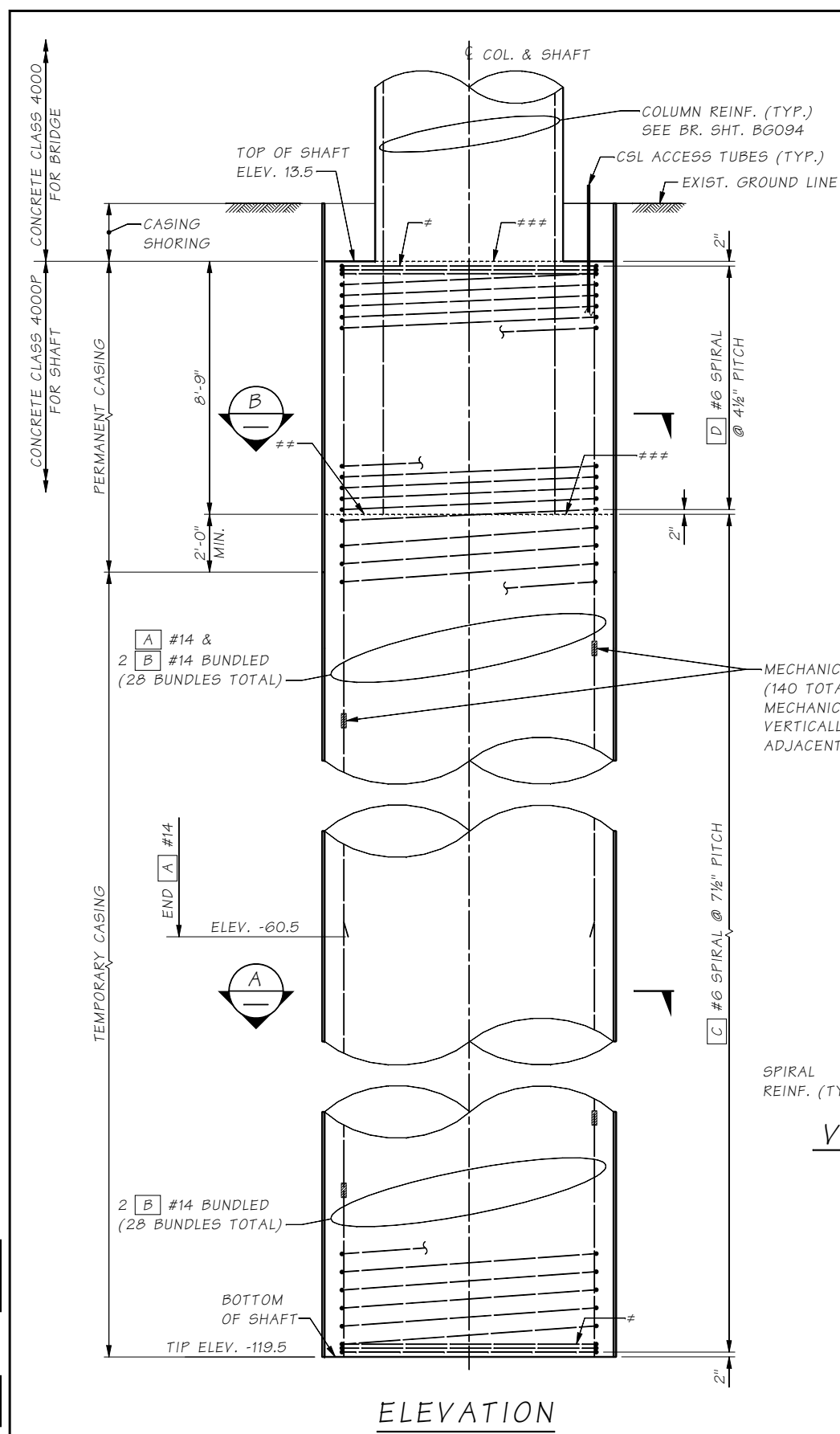

ELEVATION

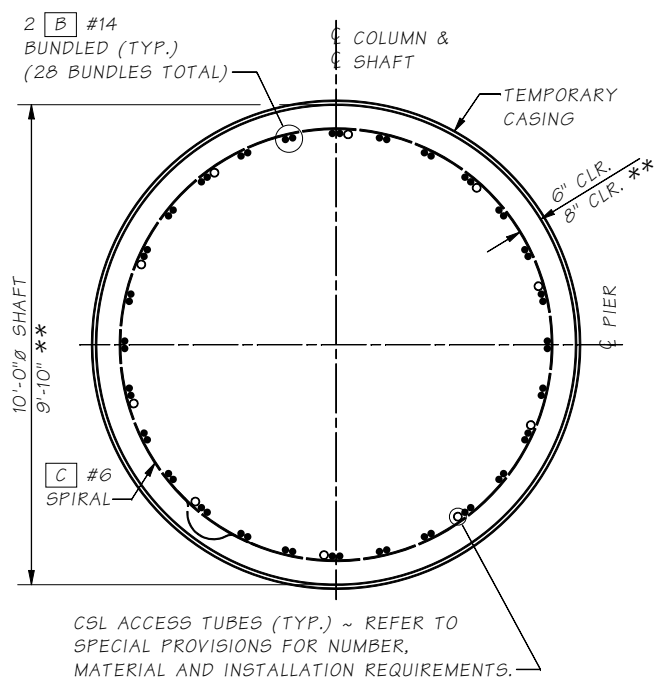

SECTION A

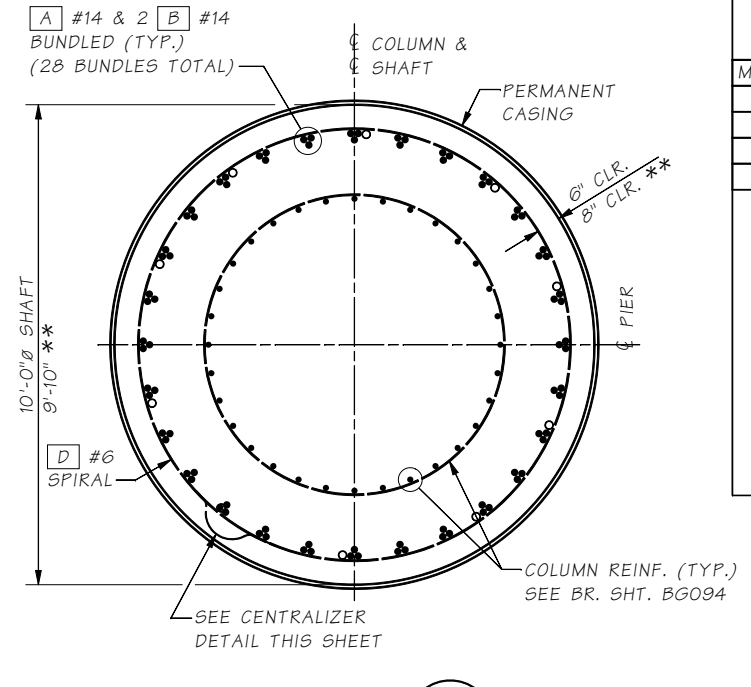

SECTION B

MECHANICAL SPLICE (TYP.) (140 TOTAL) ~ STAGGER MECHANICAL SPLICE 2'-6" VERTICALLY BETWEEN ADJACENT REBARS *

- * MECHANICAL SPLICE SHALL MEET THE REQUIREMENTS OF STD. SPEC. 6-02.3(24)F
- ** SHAFT CONSTRUCTED WITH THE OSCILLATOR METHOD. THE CONTRACTOR SHALL REVISE THE SHAFT BARLIST IF THE OSCILLATOR METHOD IS CHOSEN FOR SHAFT CONSTRUCTION
- # SEE SPIRAL TERMINATION DETAIL THIS SHEET
- ## REMOVE SEDIMENT LAITANCE & WEAK CONCRETE TO SOUND CONCRETE PRIOR TO SETTING COLUMN REINFORCEMENT
- ### CONST. JOINT WITH ROUGHENED SURFACE

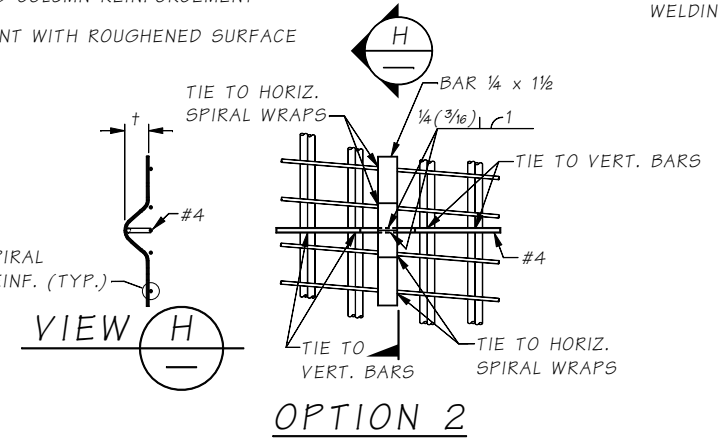
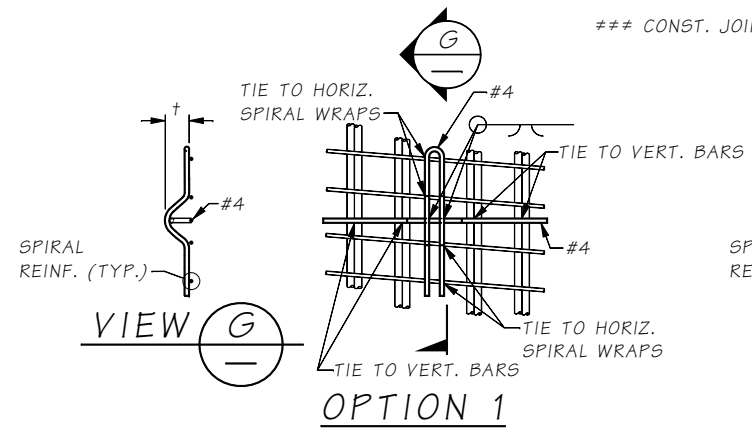

CENTRALIZER DETAIL

- NOTES:**
1. EPOXY COAT CENTRALIZER OR PAINT WITH INORGANIC ZINC AFTER FABRICATION.
 2. EACH LEG SHOULD BE TIED TO TWO VERTICAL BAR BUNDLES OR TWO SPIRALS.
 3. SEE SPECIAL PROVISIONS FOR SPACING REQUIREMENTS.
 4. † CONCRETE COVER MINUS 1/2"

SHAFT BAR LIST					
ALL REINFORCING SHALL BE ASTM A 706					
QUANTITIES ARE PER SHAFT					
MARK	SIZE	NO.	LENGTH	BEND TYPE	WT. (lbs.)
A	#14	28	73'-10 1/2"	STR.	15,824
B	#14	56	132'-9"	STR.	56,870
C	#6	1	5701'-10"	67	8,564
D	#6	1	693'-10"	67	1,042
TOTAL					82,300

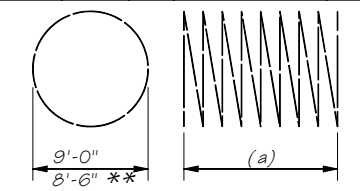

(a) ~ DETERMINED FROM PLANS
WEIGHT INCLUDES SPLICES

SPIRAL (BEND TYPE 67)

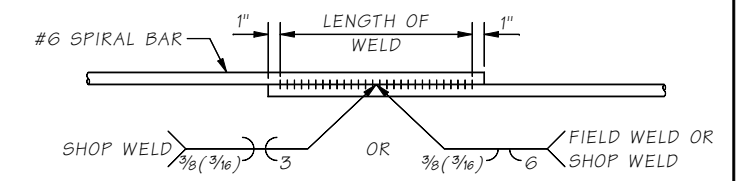

WELDED LAP SPLICE DETAIL

WELDING SHALL MEET THE REQUIREMENTS OF STD. SPEC. 6-02.3(24)E

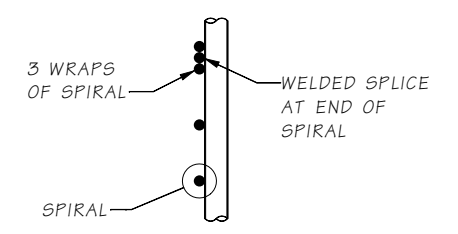

SPIRAL TERMINATION DETAIL

Bridge Design Engr. Khaleghi, B	M:\Y-Team\AWV SOUTH INTERCHANGE\window files\Pier 5N Shaft Dtls.WND			
Supervisor Moore, TM	REGION NO.	STATE	FED. AID PROJ. NO.	SHEET NO.
Designed By Lee, CS 09/08	10	WASH.		
Checked By Schultz, E 09/09	JOB NUMBER 09A803			
Detailed By Hanson, CE 09/08				
Bridge Projects Engr.				
Prelim. Plan By				
Architect/Specialist	DATE	REVISION	BY	APPD



BRIDGE AND STRUCTURES OFFICE



SR 99
ALASKAN WAY VIADUCT - REPLACEMENT
S HOLGATE ST TO S KING ST - PHASE 2
BRIDGE NO. 99/540 NB & SB

PIER 5N SHAFT DETAILS

BRIDGE SHEET NO. **BG093**
SHEET 939 OF 1475 SHEETS

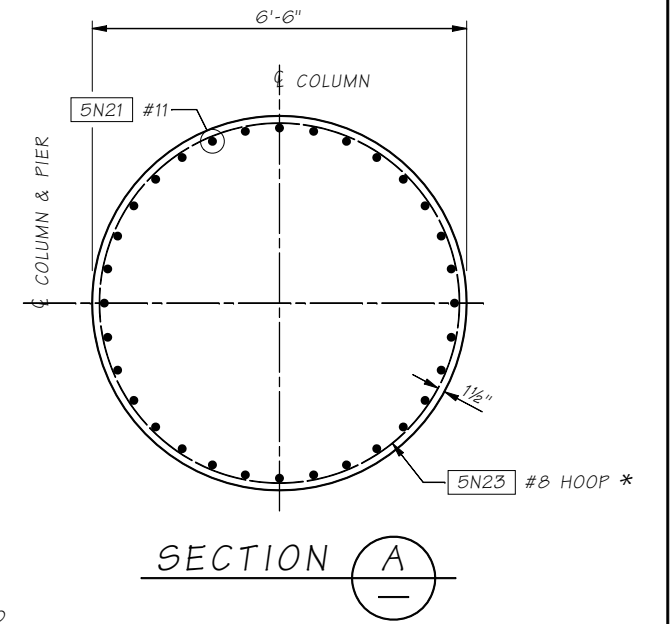
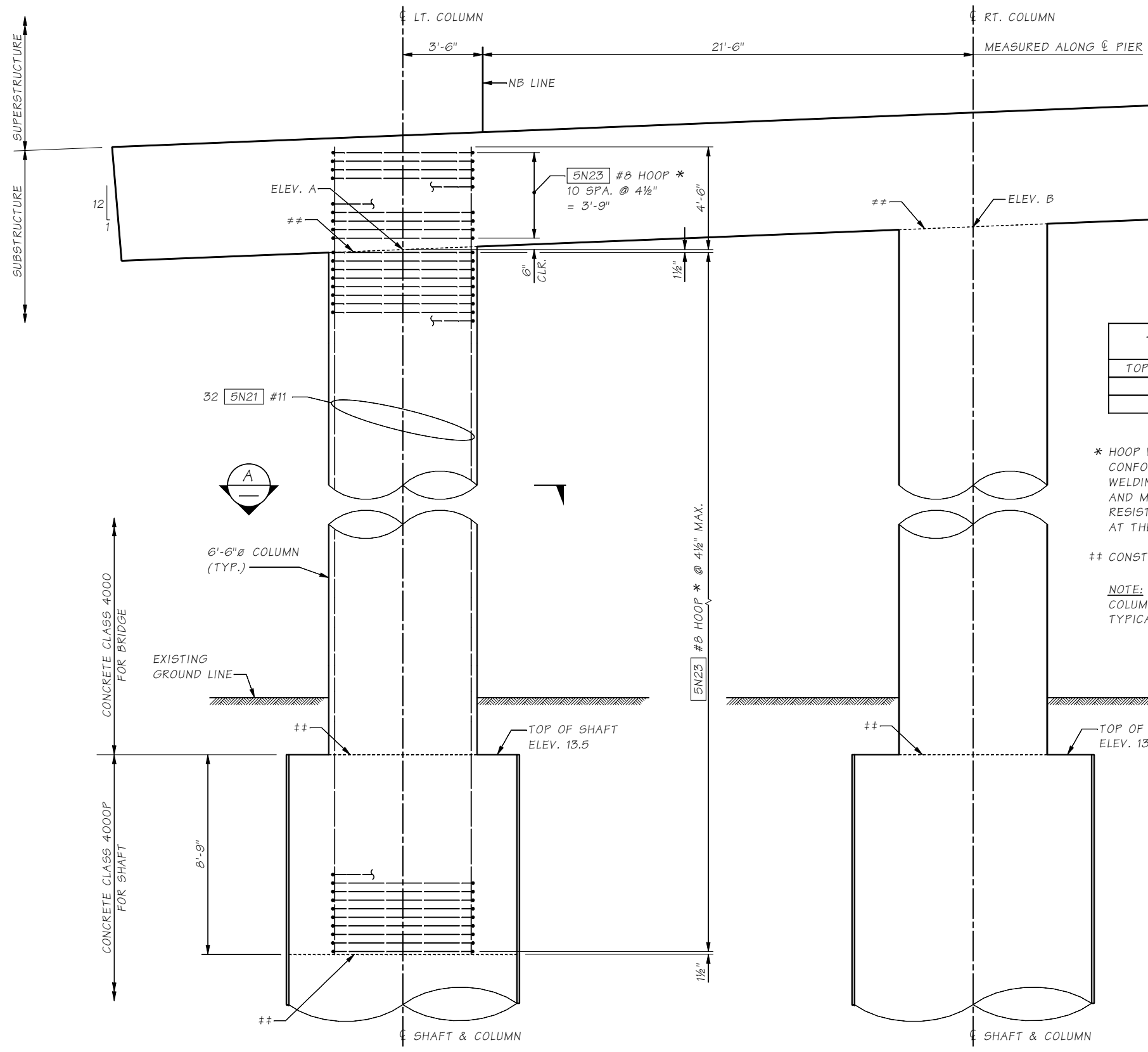
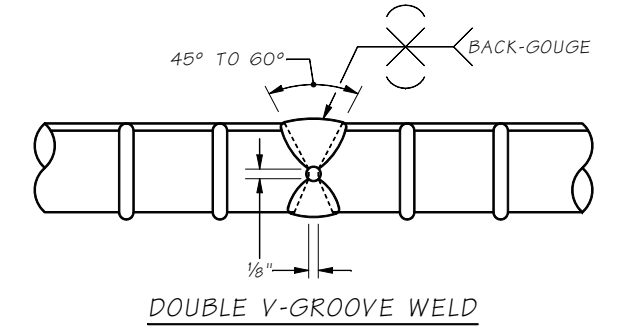
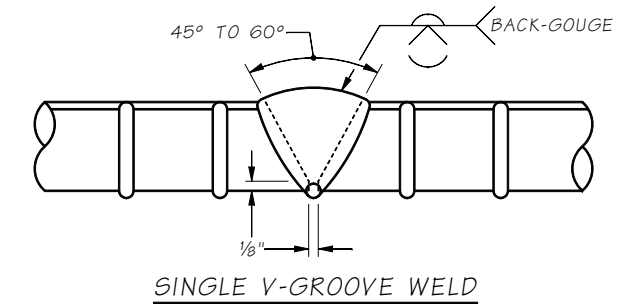

TABLE OF ELEVATIONS	
TOP OF COLUMN	ELEVATION
ELEV. A	49.77
ELEV. B	50.77

* HOOP WELD SHALL BE DIRECT BUTT-WELDED AND CONFORM TO THE CURRENT EDITION OF STRUCTURAL WELDING CODE - REINFORCING STEEL OF AWS(D1.4) AND MEET THE REQUIREMENTS OF STD. SPEC. 6-02.3(24)E. RESISTANCE BUTT WELDED SPLICE MAY BE SUBSTITUTED AT THE CONTRACTOR'S OPTION. SEE SPECIAL PROVISIONS.

CONST. JOINT w/ ROUGHENED SURFACE

NOTE:
COLUMN DETAILS & REINFORCING TYPICAL FOR ALL COLUMNS.



HOOP WELD DETAIL
ALL BACKING SHALL BE REMOVED

COLUMN ELEVATION - PIER 5N

SR 99 FILE NO. SHEET BG094

Bridge Design Engr. Khaleghi, B	M:\Y-Team\AWV SOUTH INTERCHANGE\window files\Pier 5N Col Dtl's.WND		REGION NO.	STATE	FED. AID PROJ. NO.	SHEET NO.	TOTAL SHEETS
Supervisor Moore, TM			10	WASH.			
Designed By Lee, CS	09/08		JOB NUMBER 09A803				
Checked By Schultz, E	09/09						
Detailed By Hanson, CE	09/08						
Bridge Projects Engr.							
Prelim. Plan By	2/17/10	REVISED SHEET	CSL	TMM			
Architect/Specialist	DATE	REVISION	BY	APPD			



BRIDGE AND STRUCTURES OFFICE

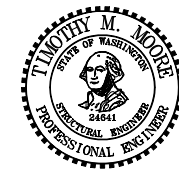

SR 99
ALASKAN WAY VIADUCT - REPLACEMENT
S HOLGATE ST TO S KING ST - PHASE 2
BRIDGE NO. 99/540 NB & SB
PIER 5N COLUMN DETAILS

BRIDGE SHEET NO. BG094
SHEET 940 OF 1475 SHEETS

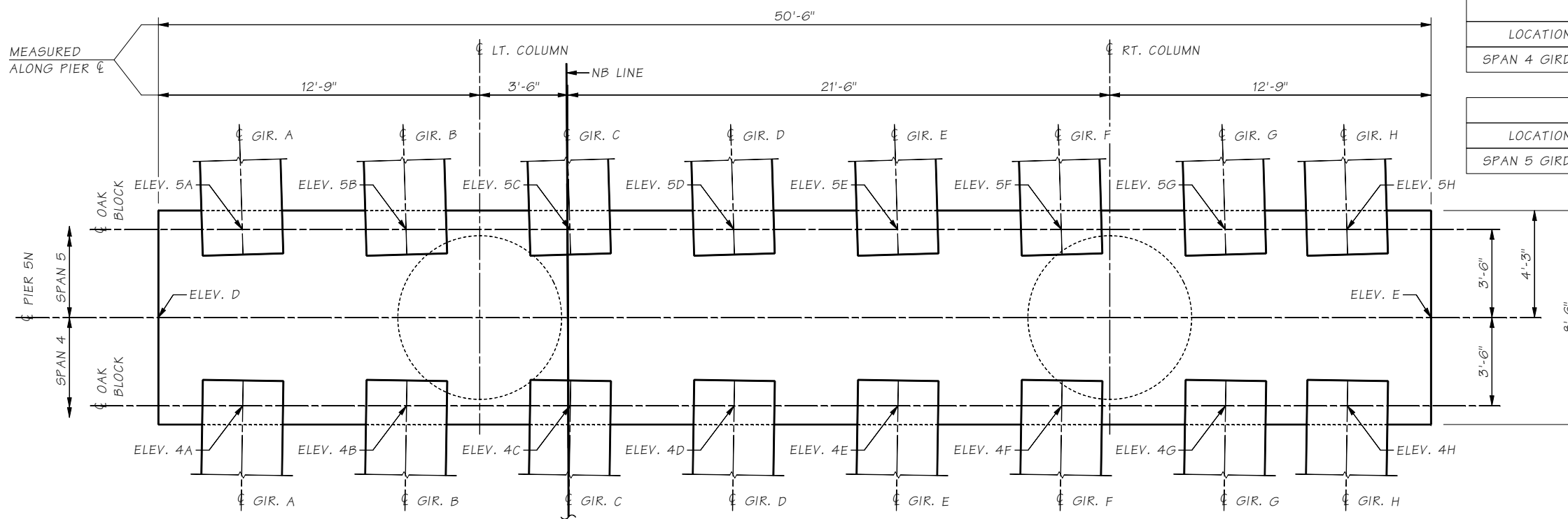

PLAN

LOCATION	4A	4B	4C	4D	4E	4F	4G	4H
SPAN 4 GIRDERS	54.68	54.94	55.20	55.46	55.72	55.98	56.25	56.44

LOCATION	5A	5B	5C	5D	5E	5F	5G	5H
SPAN 5 GIRDERS	54.72	54.98	55.24	55.50	55.76	56.02	56.28	56.48

LOCATION	ELEVATION
D	54.26
E	56.28
F	61.58
G	63.58

NOTE:
SEE FRAMING PLAN FOR GIRDER SPACING.

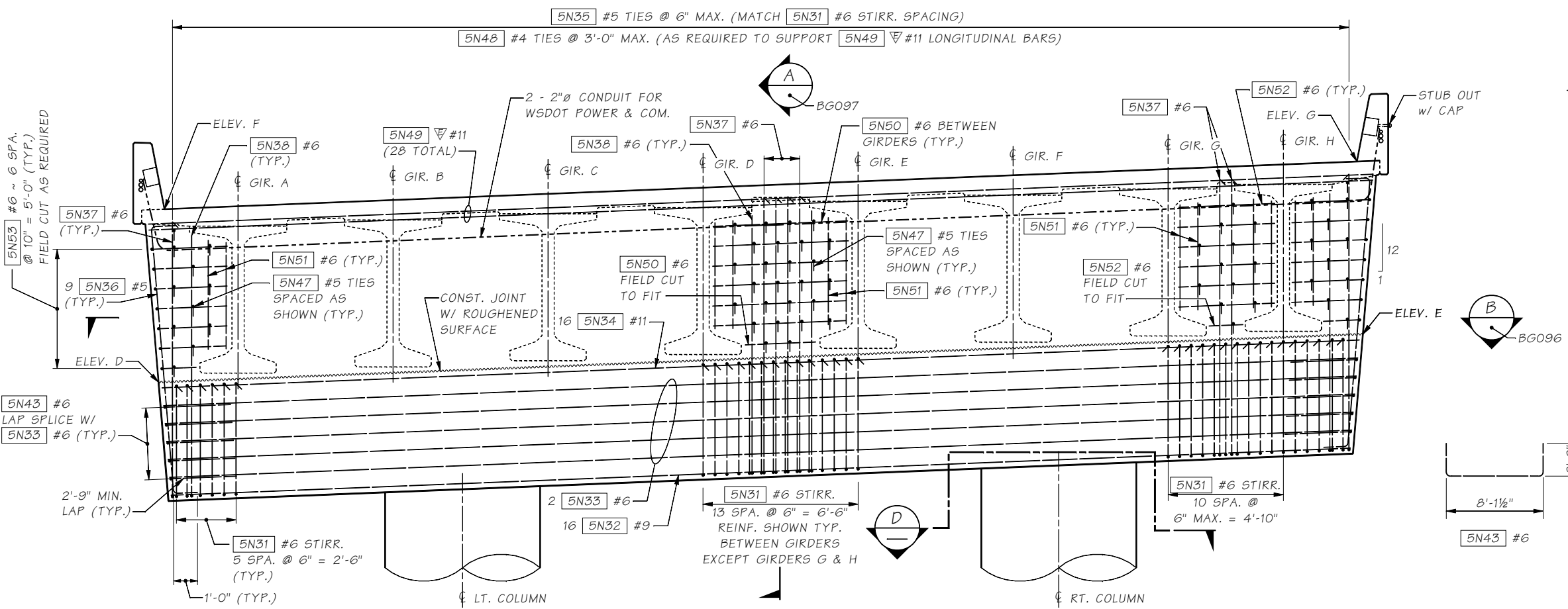

ELEVATION

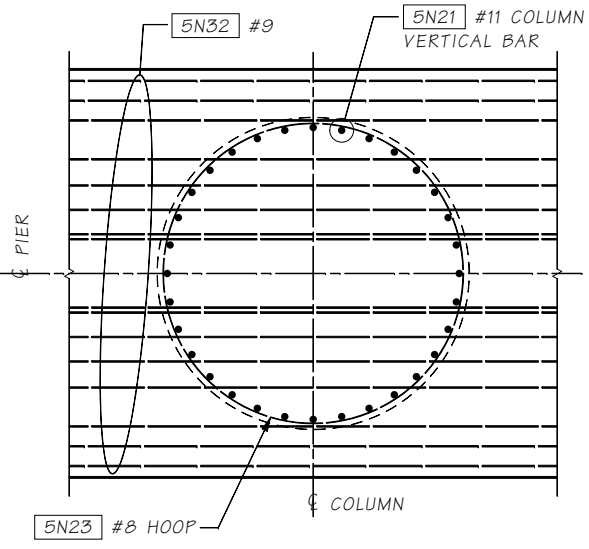

SECTION D

TRANSVERSE REINFORCING NOT SHOWN FOR CLARITY. ADJUST LONGITUDINAL BAR, TRANSVERSE STIRRUP, AND THE TIE SPACING AS REQUIRED TO CLEAR COLUMN VERTICAL BARS.

- NOTES:
1. SLAB REINFORCING NOT SHOWN FOR CLARITY.
 2. ADJUST STIRRUP AND TIE SPACING AS REQUIRED TO CLEAR COLUMN VERTICAL BARS.
 3. DIAPHRAGM REINFORCING SHOWN FOR SPAN 4 FACE ONLY. SEE SECTION B FOR DETAILS.

SR 99 FILE NO. SHEET BG095

Bridge Design Engr. Khaleghi, B	M:\Y-Team\AWV SOUTH INTERCHANGE\window files\Pier 5N X-Beam Plan-Elev.WND		REGION NO.	STATE	FED. AID PROJ. NO.	SHEET NO.	TOTAL SHEETS
Supervisor Moore, TM			10	WASH.			
Designed By Lee, CS	09/08						
Checked By Glassford, P	09/09						
Detailed By Hanson, CE	09/08						
Bridge Projects Engr.			JOB NUMBER				
Prelim. Plan By	2/17/10	REVISED SHEET	09A803				
Architect/Specialist	DATE	REVISION	BY	APPD			



BRIDGE AND STRUCTURES OFFICE

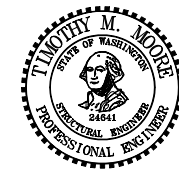

SR 99
ALASKAN WAY VIADUCT - REPLACEMENT
S HOLGATE ST TO S KING ST - PHASE 2
BRIDGE NO. 99/540 NB & SB

PIER 5N CROSSBEAM
PLAN AND ELEVATION

BRIDGE SHEET NO. BG095
SHEET 941 OF 1475 SHEETS

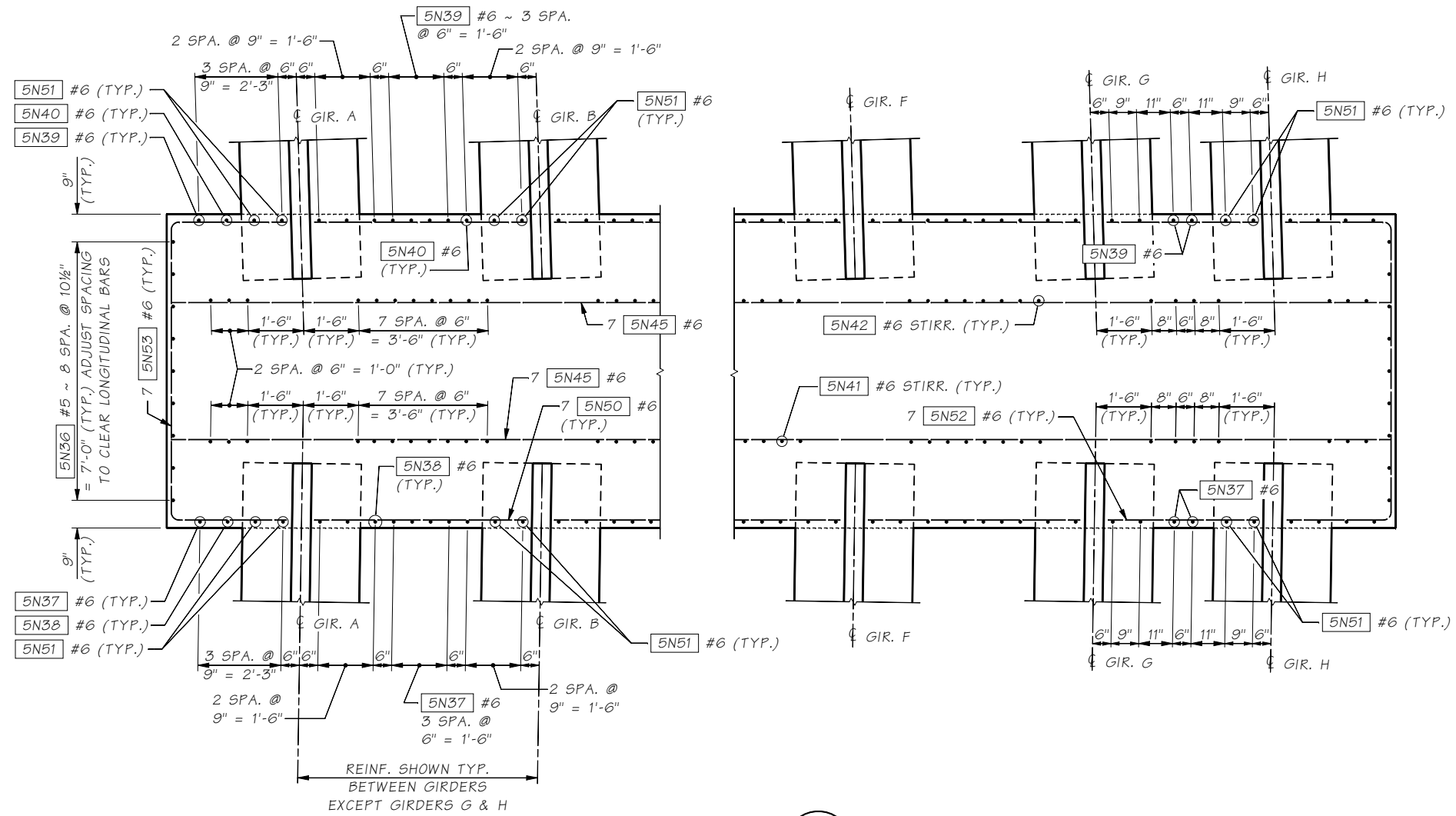

SECTION B
BG095

Bridge Design Engr.	Khaleghi, B	M:\Y-Team\AWV SOUTH INTERCHANGE\window files\Pier 5N X-Beam Dtls.WND			
Supervisor	Moore, TM	REGION NO.	STATE	FED. AID PROJ. NO.	SHEET NO.
Designed By	Lee, CS 09/08	10	WASH.		TOTAL SHEETS
Checked By	Glassford, P 09/09	JOB NUMBER			
Detailed By	Hanson, CE 09/08	09A803			
Bridge Projects Engr.					
Prelim. Plan By					
Architect/Specialist		DATE	REVISION	BY	APPD



BRIDGE AND STRUCTURES OFFICE

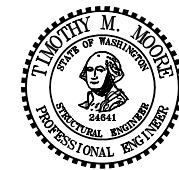

SR 99
ALASKAN WAY VIADUCT - REPLACEMENT
S HOLGATE ST TO S KING ST - PHASE 2
BRIDGE NO. 99/540 NB & SB

PIER 5N CROSSBEAM DETAILS 1 OF 2

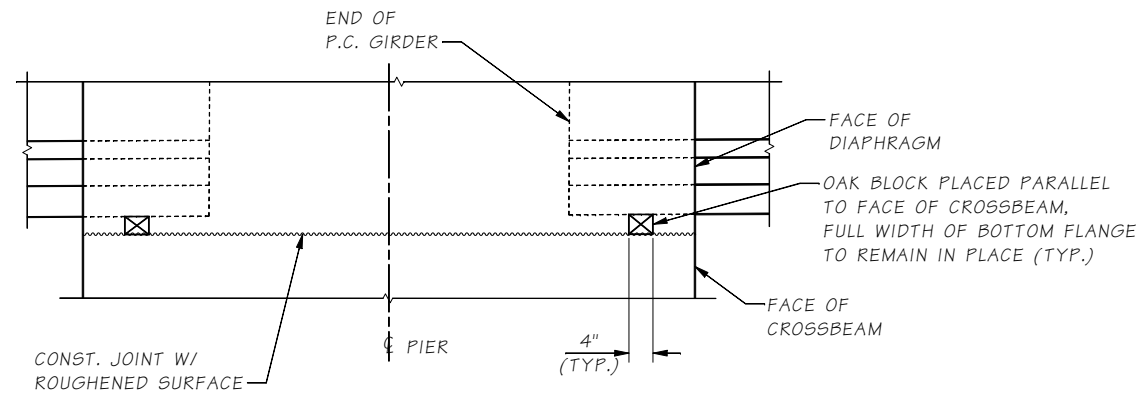

OAK BLOCK DETAIL
LONGITUDINAL DIMENSIONS ARE NORMAL TO SKEW

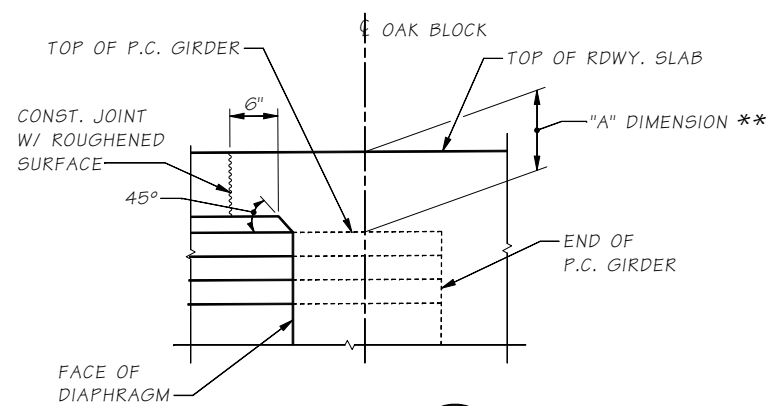

DETAIL C
REINFORCING NOT SHOWN FOR CLARITY

** SEE "GIRDER SCHEDULE" SHEETS

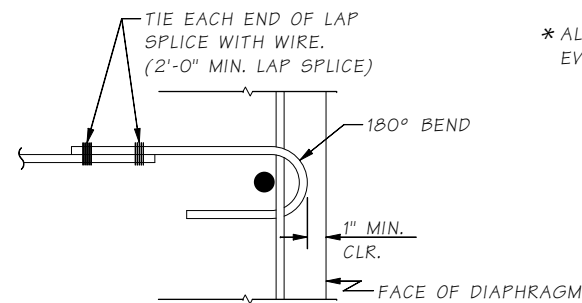

TIE BAR DETAIL

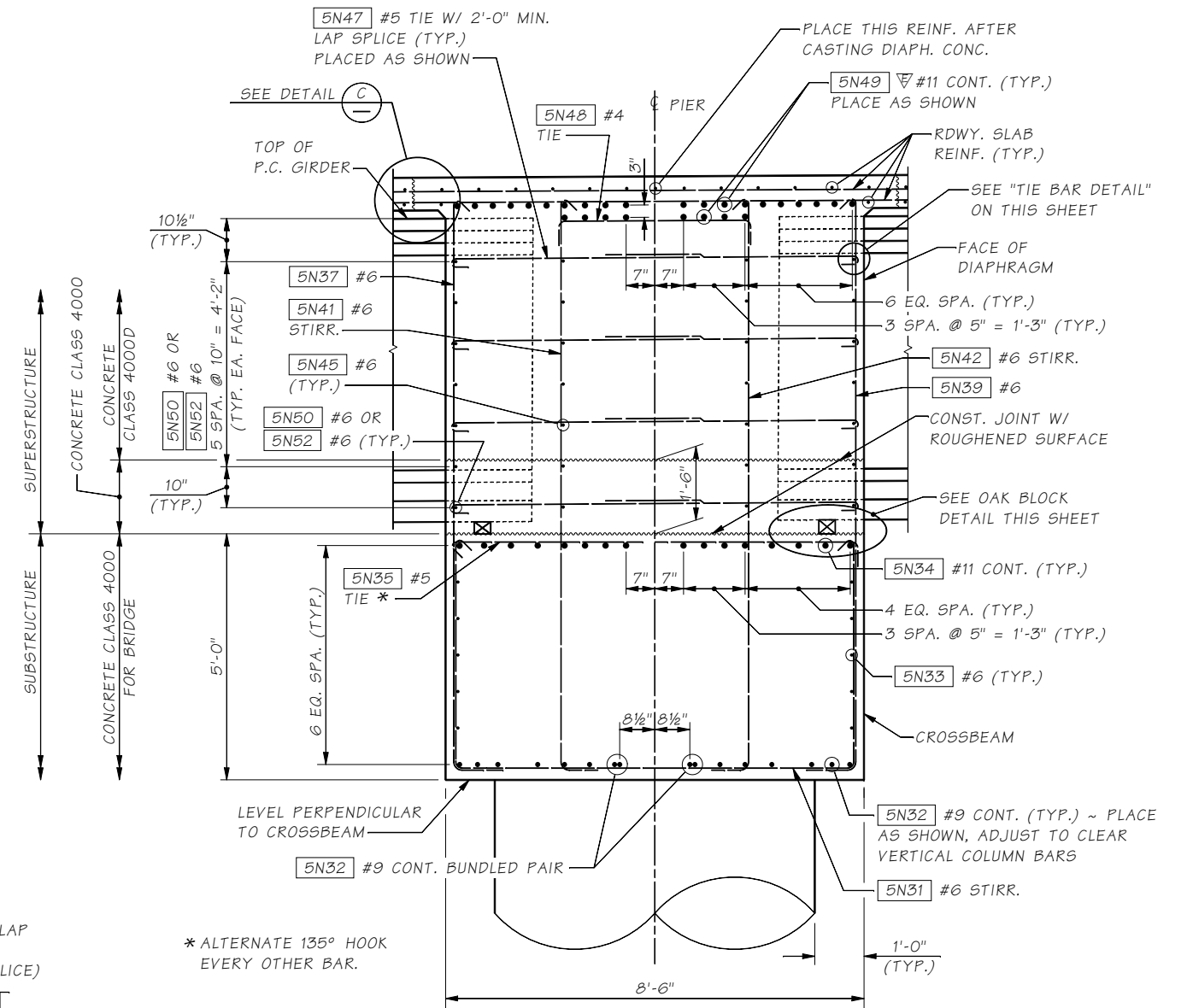

SECTION A
BG095

- NOTES:
- LONGITUDINAL DIMENSIONS ARE NORMAL TO SKEW.
 - FOR CONCRETE PLACEMENT PROCEDURE, SEE "CONSTRUCTION SEQUENCE" SHEET.

SR 99 FILE NO. SHEET BG097

Bridge Design Engr.	Khaleghi, B	M:\Y-Team\AW SOUTH INTERCHANGE\window files\Pier 5N X-Beam Dtls 2.WND			
Supervisor	Moore, TM	REGION NO.	STATE	FED. AID PROJ. NO.	SHEET NO.
Designed By	Lee, CS	10	WASH.		TOTAL SHEETS
Checked By	Glassford, P	JOB NUMBER 09A803			
Detailed By	Lemcke, DR				
Bridge Projects Engr.					
Prelim. Plan By					
Architect/Specialist		DATE	REVISION	BY	APPD



BRIDGE AND STRUCTURES OFFICE



SR 99
ALASKAN WAY VIADUCT - REPLACEMENT
S HOLGATE ST TO S KING ST - PHASE 2
BRIDGE NO. 99/540 NB & SB
PIER 5N CROSSBEAM DETAILS 2 OF 2

BRIDGE SHEET NO. **BG097**
SHEET **943** OF **1475** SHEETS

SR 99 FILE NO. SHEET BG098

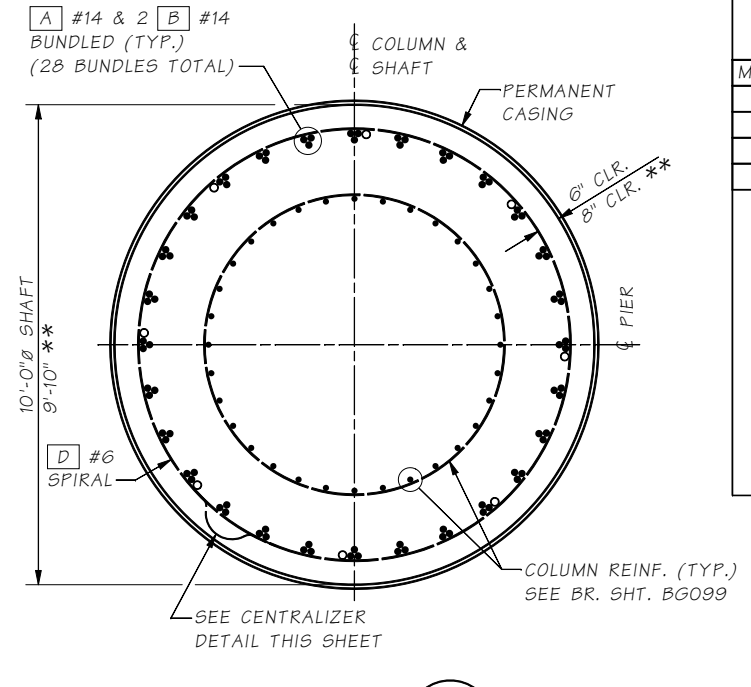
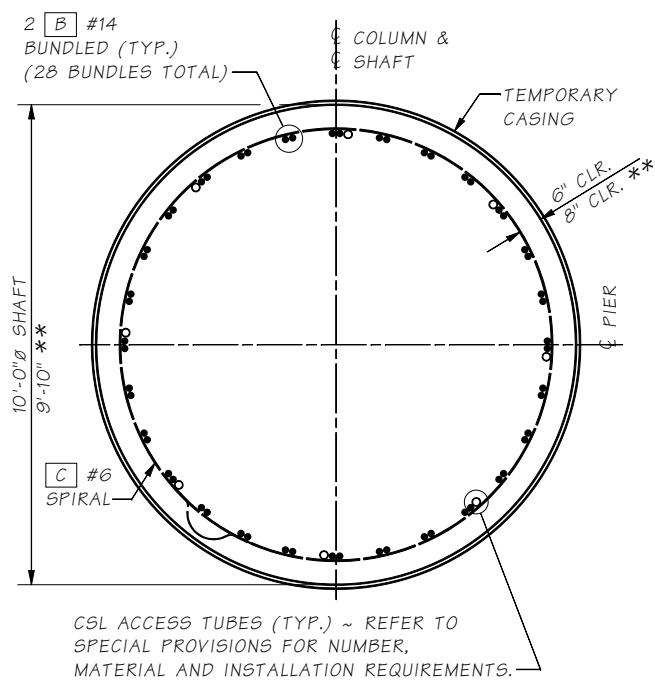
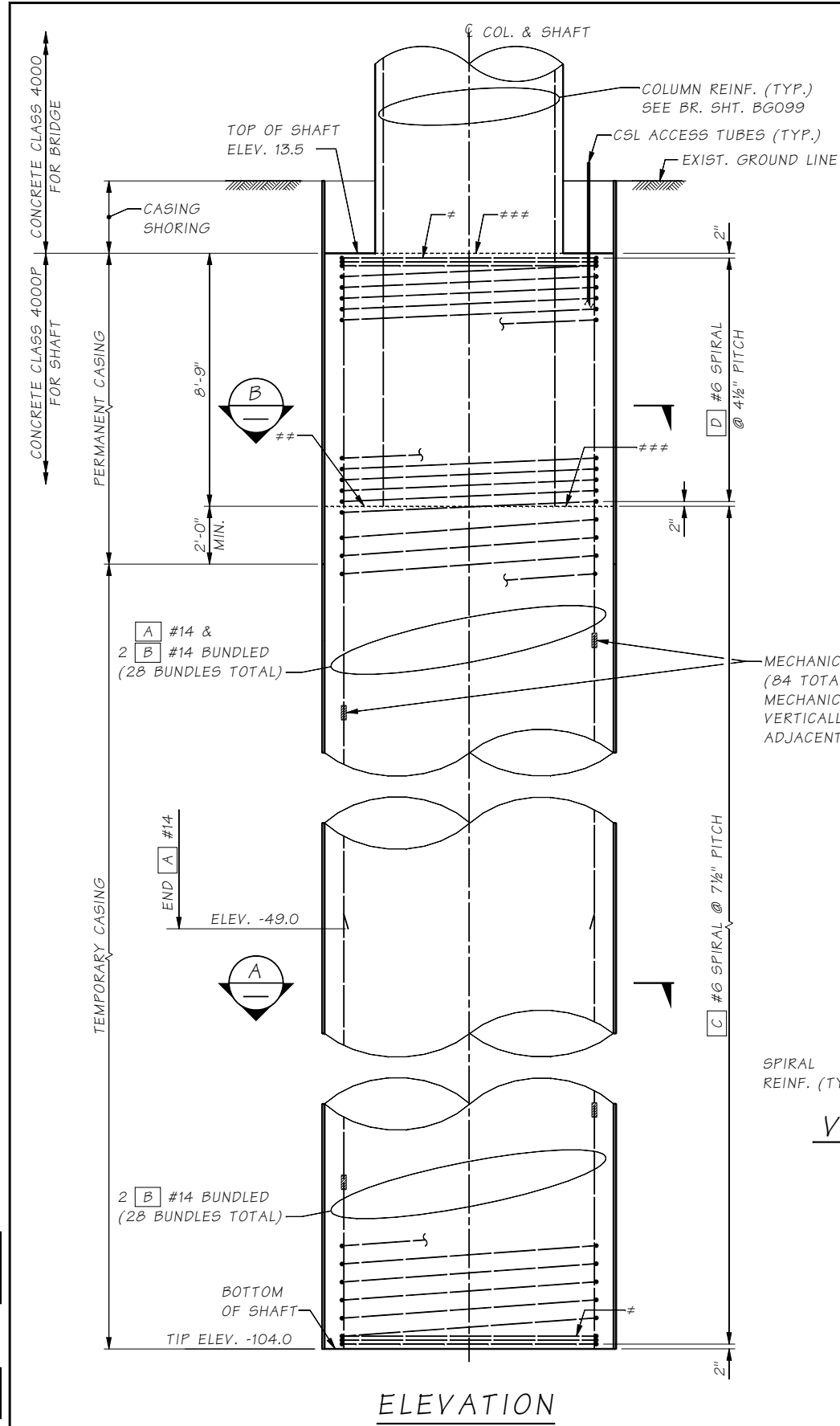

SHAFT BAR LIST

ALL REINFORCING SHALL BE ASTM A 706
QUANTITIES ARE PER SHAFT

MARK	SIZE	NO.	LENGTH	BEND TYPE	WT. (lbs.)
A	#14	28	62'-4 1/2"	STR.	13,361
B	#14	56	117'-3"	STR.	50,230
C	#6	1	4997'-7"	67	7,506
D	#6	1	693'-10"	67	1,042
TOTAL					72,139

(a) ~ DETERMINED FROM PLANS
WEIGHT INCLUDES SPLICES
SPIRAL (BEND TYPE 67)

MECHANICAL SPLICE (TYP.) (84 TOTAL) ~ STAGGER MECHANICAL SPLICE 2'-6" VERTICALLY BETWEEN ADJACENT REBARS *

- * MECHANICAL SPLICE SHALL MEET THE REQUIREMENTS OF STD. SPEC. 6-02.3(24)F
- ** SHAFT CONSTRUCTED WITH THE OSCILLATOR METHOD. THE CONTRACTOR SHALL REVISE THE SHAFT BARLIST IF THE OSCILLATOR METHOD IS CHOSEN FOR SHAFT CONSTRUCTION
- # SEE SPIRAL TERMINATION DETAIL THIS SHEET
- ** REMOVE SEDIMENT LAITANCE & WEAK CONCRETE TO SOUND CONCRETE PRIOR TO SETTING COLUMN REINFORCEMENT
- *** CONST. JOINT WITH ROUGHENED SURFACE

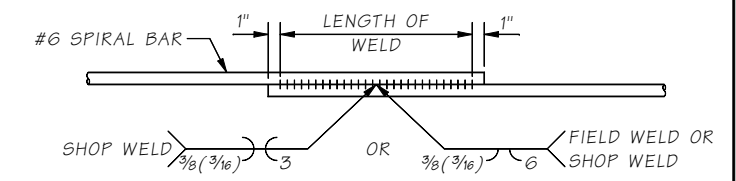

WELDED LAP SPLICE DETAIL
WELDING SHALL MEET THE REQUIREMENTS OF STD. SPEC. 6-02.3(24)E

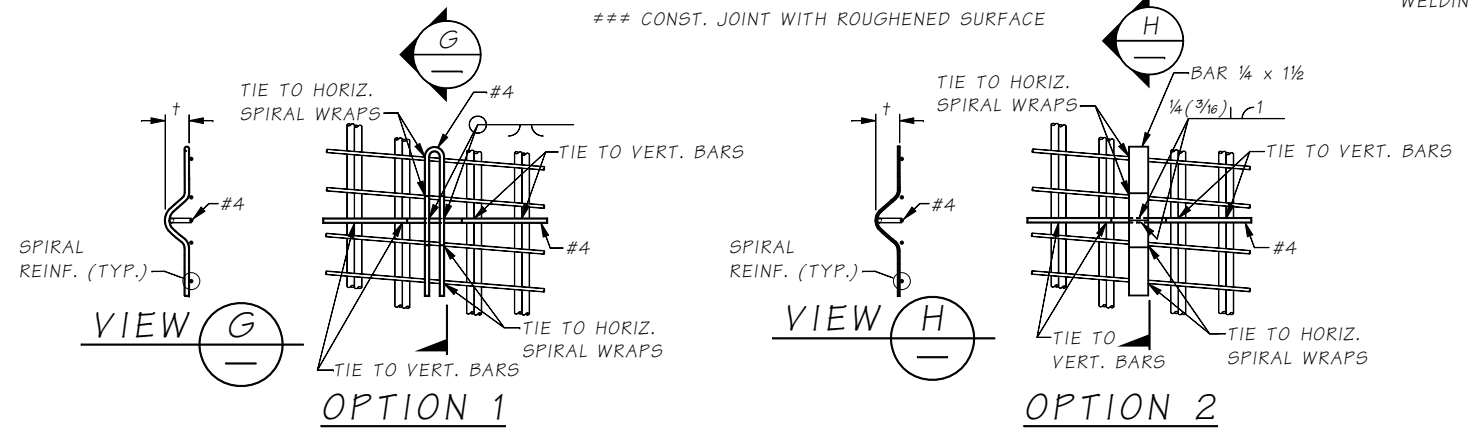

CENTRALIZER DETAIL

- NOTES:**
1. EPOXY COAT CENTRALIZER OR PAINT WITH INORGANIC ZINC AFTER FABRICATION.
 2. EACH LEG SHOULD BE TIED TO TWO VERTICAL BAR BUNDLES OR TWO SPIRALS.
 3. SEE SPECIAL PROVISIONS FOR SPACING REQUIREMENTS.
 4. † CONCRETE COVER MINUS 1/2"

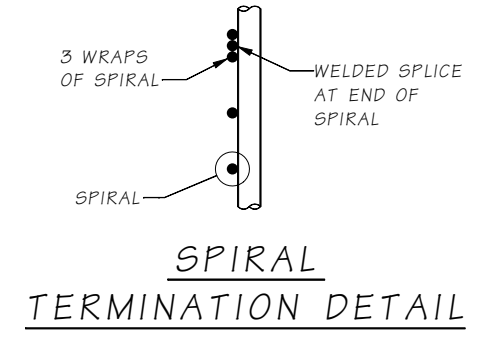

SPIRAL TERMINATION DETAIL

Bridge Design Engr. Khaleghi, B	M:\Y-Team\AWV SOUTH INTERCHANGE\window files\Pier 6N Shaft Dtl.s.WND			
Supervisor Moore, TM	REGION NO.	STATE	FED. AID PROJ. NO.	SHEET NO.
Designed By Lee, CS 09/08	10	WASH.		
Checked By Schultz, E 09/09	JOB NUMBER 09A803			
Detailed By Lemcke, DR 05/09				
Bridge Projects Engr.	DATE	REVISION	BY	APPD
Prelim. Plan By				
Architect/Specialist				



BRIDGE AND STRUCTURES OFFICE

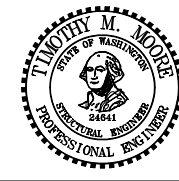

SR 99
ALASKAN WAY VIADUCT - REPLACEMENT
S HOLGATE ST TO S KING ST - PHASE 2
BRIDGE NO. 99/540 NB & SB

PIER 6N SHAFT DETAILS

BRIDGE SHEET NO. BG098
SHEET 944 OF 1475 SHEETS

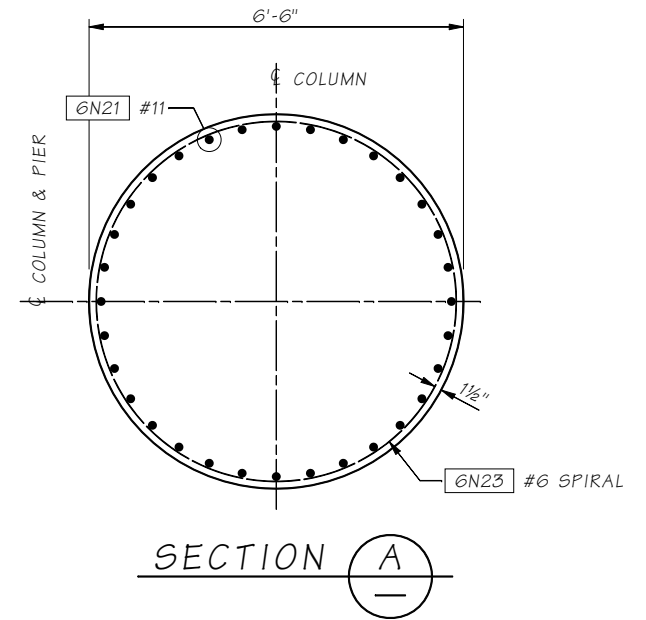
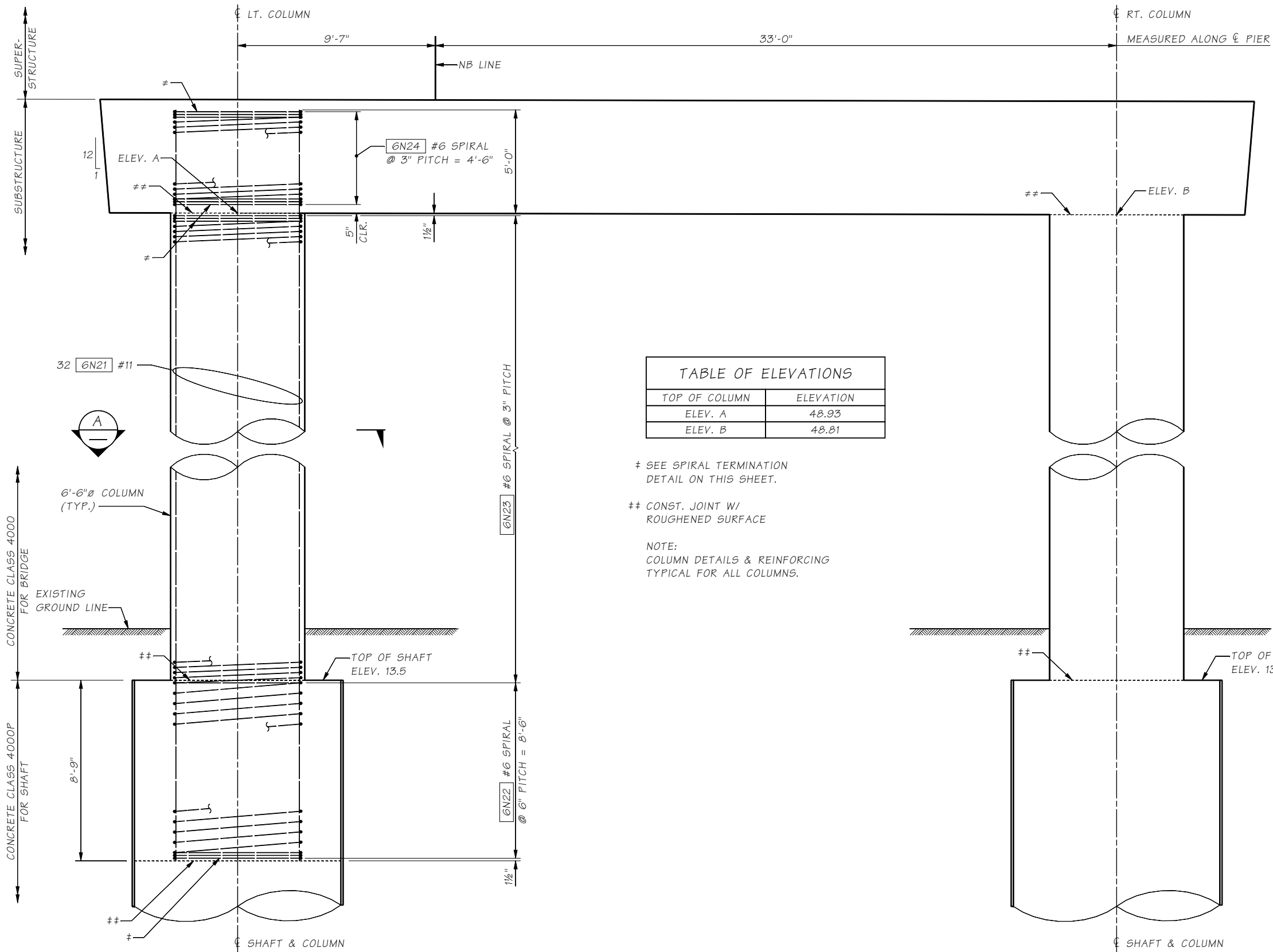

TABLE OF ELEVATIONS

TOP OF COLUMN	ELEVATION
ELEV. A	48.93
ELEV. B	48.81

‡ SEE SPIRAL TERMINATION
DETAIL ON THIS SHEET.

‡‡ CONST. JOINT W/
ROUGHENED SURFACE

NOTE:
COLUMN DETAILS & REINFORCING
TYPICAL FOR ALL COLUMNS.

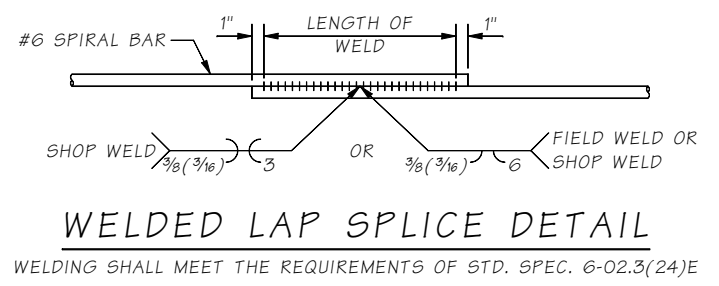
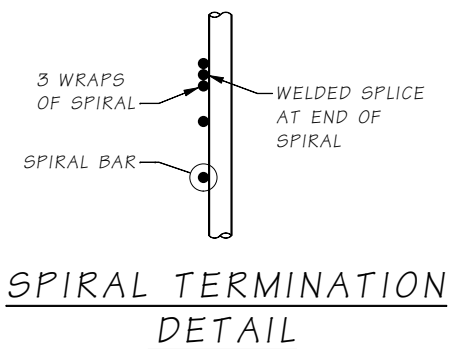

COLUMN ELEVATION - PIER 6N

SR 99 FILE NO. SHEET BG099

Bridge Design Engr.	Khaleghi, B	M:\Y-Team\AWV SOUTH INTERCHANGE\window files\Pier 6N Col Dtls.WND			
Supervisor	Moore, TM	REGION NO.	STATE	FED. AID PROJ. NO.	SHEET NO.
Designed By	Lee, CS 09/08	10	WASH.		TOTAL SHEETS
Checked By	Schultz, E 09/09	JOB NUMBER 09A803			
Detailed By	Lemcke, DR 05/09				
Bridge Projects Engr.					
Prelim. Plan By					
Architect/Specialist		DATE	REVISION	BY	APPD



BRIDGE AND STRUCTURES OFFICE

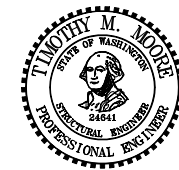

SR 99
ALASKAN WAY VIADUCT - REPLACEMENT
S HOLGATE ST TO S KING ST - PHASE 2
BRIDGE NO. 99/540 NB & SB

BRIDGE SHEET NO. BG099
SHEET 945 OF 1475 SHEETS

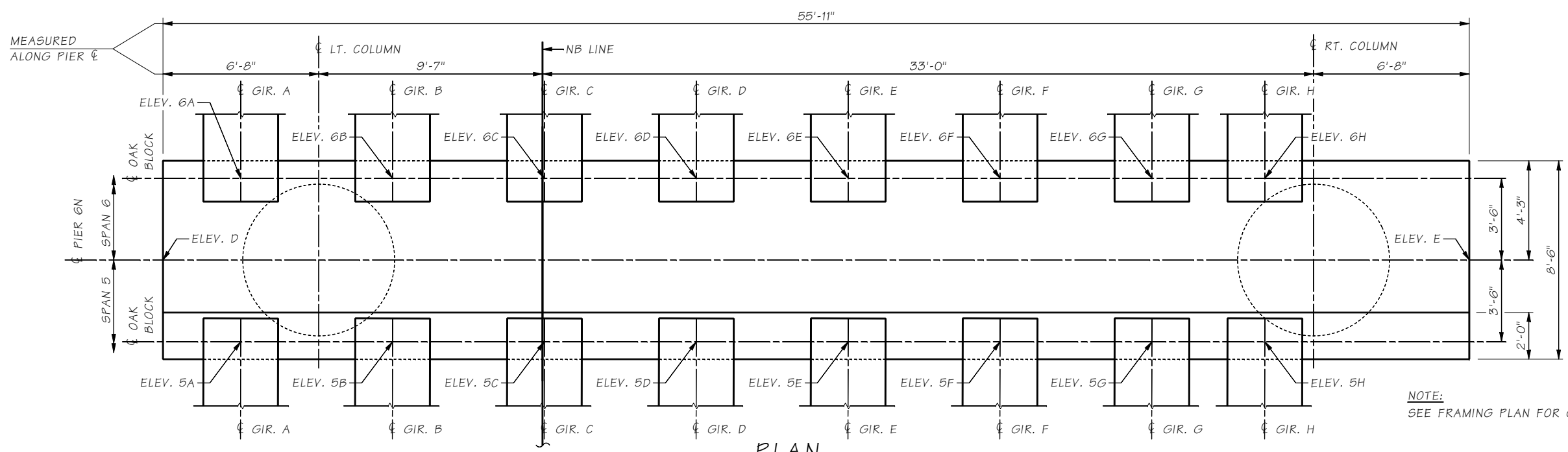

PLAN

TABLE OF ELEVATIONS @ TOP OF OAK BLOCK				
LOCATION	5A	5B	5C	5D
SPAN 5 GIRDERS	54.99	54.99	54.98	54.98
LOCATION	5E	5F	5G	5H
SPAN 5 GIRDERS	54.97	54.97	54.96	54.96
LOCATION	6A	6B	6C	6D
SPAN 6 GIRDERS	54.68	54.67	54.65	54.63
LOCATION	6E	6F	6G	6H
SPAN 6 GIRDERS	54.62	54.60	54.58	54.57

TABLE OF ELEVATIONS	
LOCATION	ELEVATION
D	54.44
E	54.29
F	61.98
G	61.89

NOTE:
SEE FRAMING PLAN FOR GIRDER SPACING.

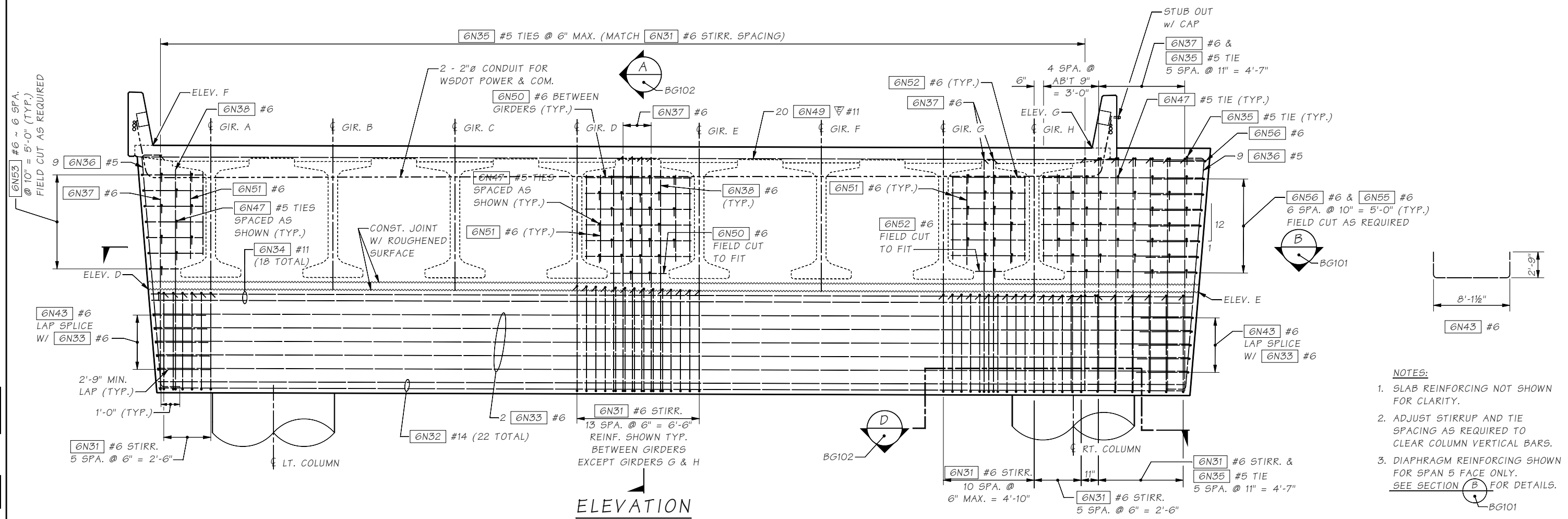

ELEVATION

- NOTES:
1. SLAB REINFORCING NOT SHOWN FOR CLARITY.
 2. ADJUST STIRRUP AND TIE SPACING AS REQUIRED TO CLEAR COLUMN VERTICAL BARS.
 3. DIAPHRAGM REINFORCING SHOWN FOR SPAN 5 FACE ONLY. SEE SECTION B FOR DETAILS.

SR 99 FILE NO. SHEET BG100

Bridge Design Engr. Khaleghi, B	M:\Y-Team\AWW SOUTH INTERCHANGE\window files\Pier 6N X-Beam Plan-Elev.WND				
Supervisor Moore, TM	REGION NO.	STATE	FED. AID PROJ. NO.	SHEET NO.	TOTAL SHEETS
Designed By Lee, CS 09/08	10	WASH.			
Checked By Glassford, P 09/09	JOB NUMBER 09A803				
Detailed By Lemcke, DR 05/09					
Bridge Projects Engr.					
Prelim. Plan By					
Architect/Specialist	DATE	REVISION	BY	APPD	



BRIDGE AND STRUCTURES OFFICE

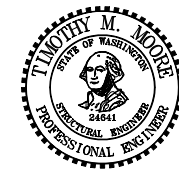

SR 99
ALASKAN WAY VIADUCT - REPLACEMENT
S HOLGATE ST TO S KING ST - PHASE 2
BRIDGE NO. 99/540 NB & SB

PIER 6N CROSSBEAM
PLAN AND ELEVATION

BRIDGE SHEET NO. BG100
SHEET 946 OF 1475 SHEETS

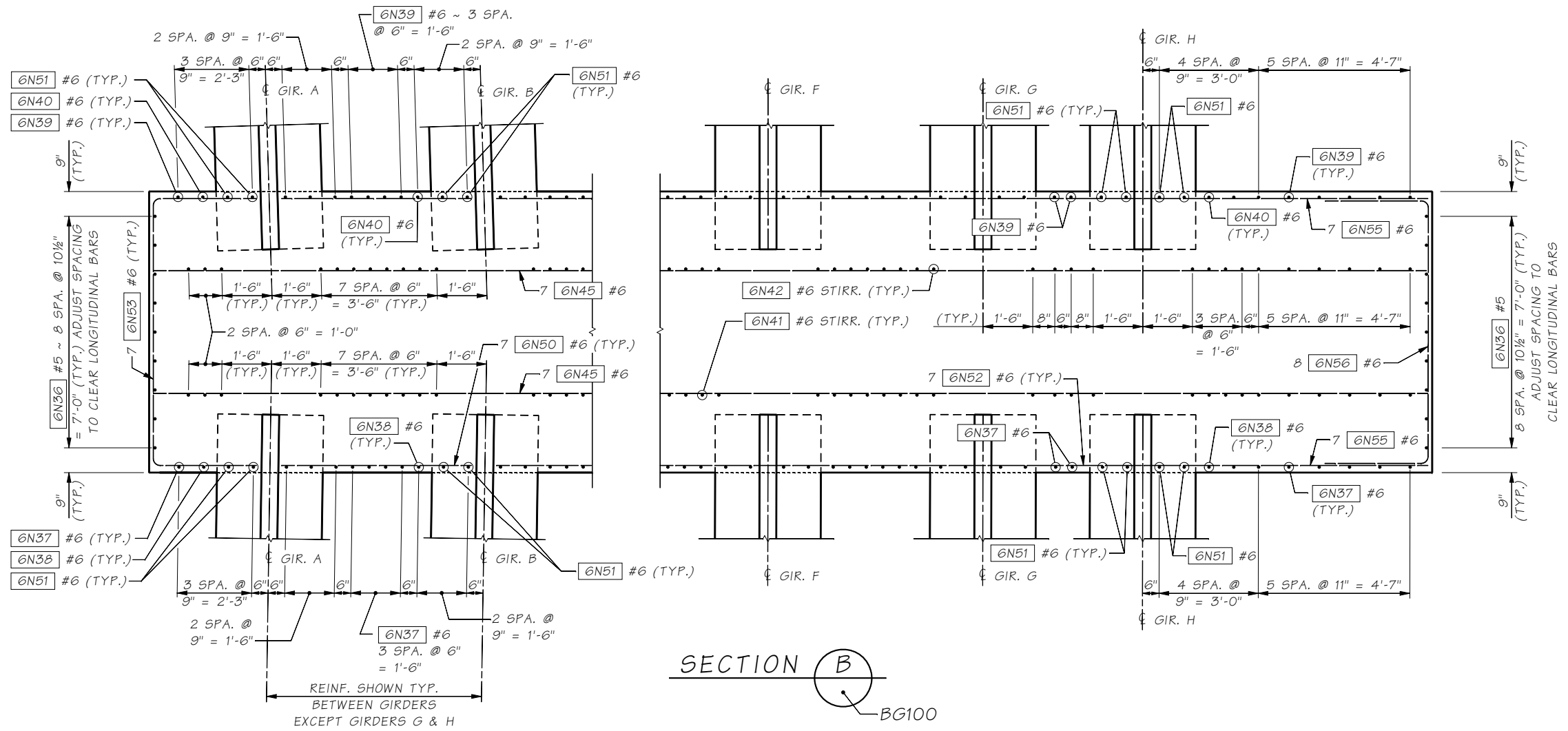

Bridge Design Engr.	Khaleghi, B	M:\Y-Team\AWV SOUTH INTERCHANGE\window files\Pier 6N X-Beam Dtls.WND			
Supervisor	Moore, TM	REGION NO.	STATE	FED. AID PROJ. NO.	SHEET NO.
Designed By	Lee, CS	10	WASH.		TOTAL SHEETS
Checked By	Glassford, P	JOB NUMBER 09A803			
Detailed By	Lemcke, DR				
Bridge Projects Engr.					
Prelim. Plan By					
Architect/Specialist		DATE	REVISION	BY	APPD



BRIDGE AND STRUCTURES OFFICE

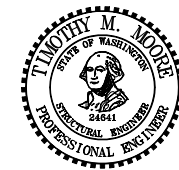

SR 99
ALASKAN WAY VIADUCT - REPLACEMENT
S HOLGATE ST TO S KING ST - PHASE 2
BRIDGE NO. 99/540 NB & SB
PIER 6N CROSSBEAM DETAILS 1 OF 2

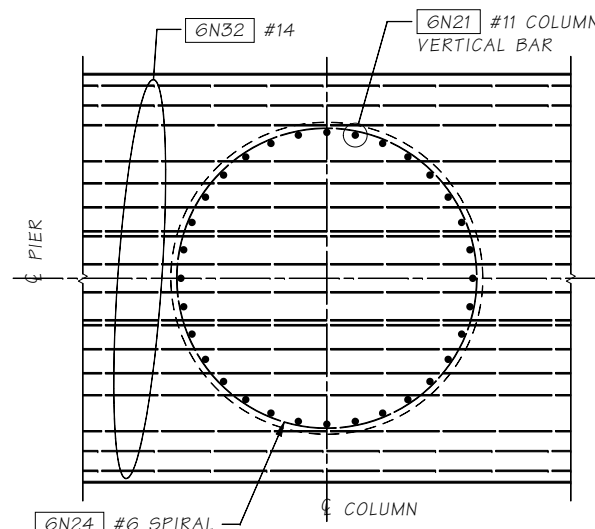

SECTION D
 TRANSVERSE REINFORCING NOT SHOWN FOR CLARITY. ADJUST LONGITUDINAL BAR, TRANSVERSE STIRRUP, AND THE TIE SPACING AS REQUIRED TO CLEAR COLUMN VERTICAL BARS.

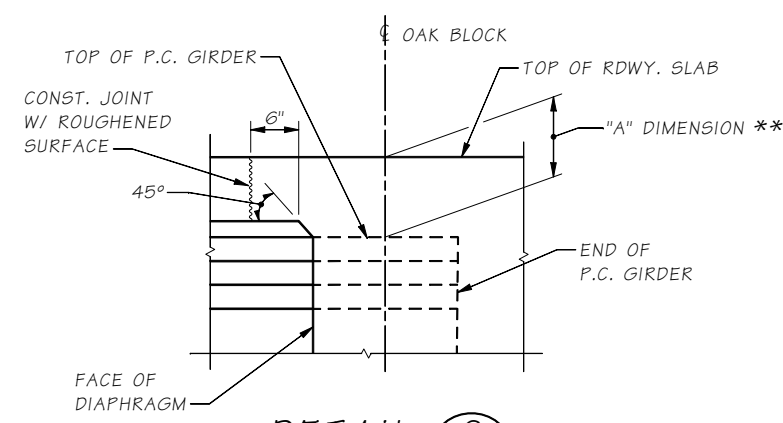

DETAIL C
 REINFORCING NOT SHOWN FOR CLARITY
 ** SEE \"GIRDER SCHEDULE\" SHEETS

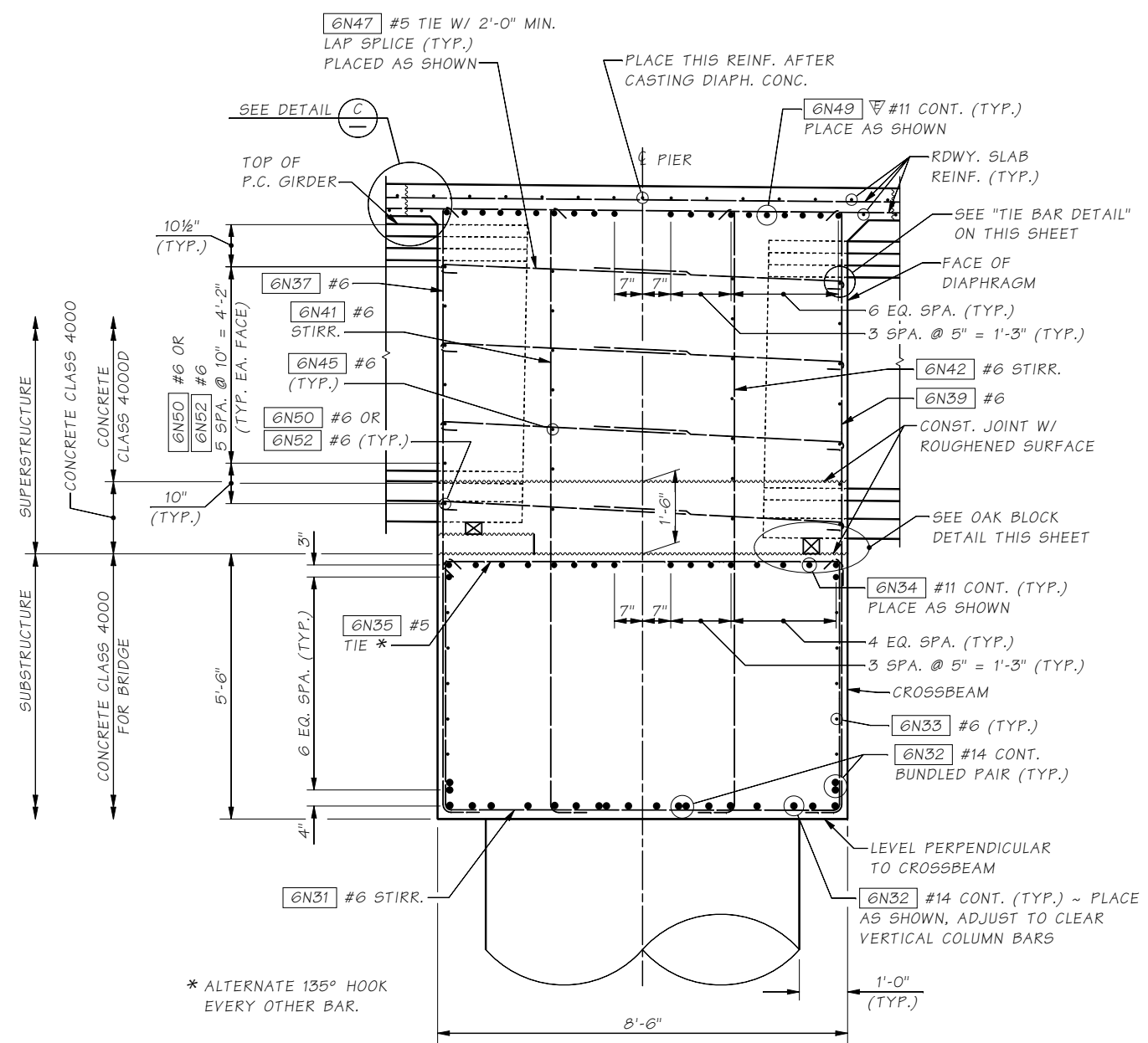

SECTION A
 BG100

- NOTES:
- LONGITUDINAL DIMENSIONS ARE NORMAL TO SKEW.
 - FOR CONCRETE PLACEMENT PROCEDURE, SEE \"CONSTRUCTION SEQUENCE\" SHEET.

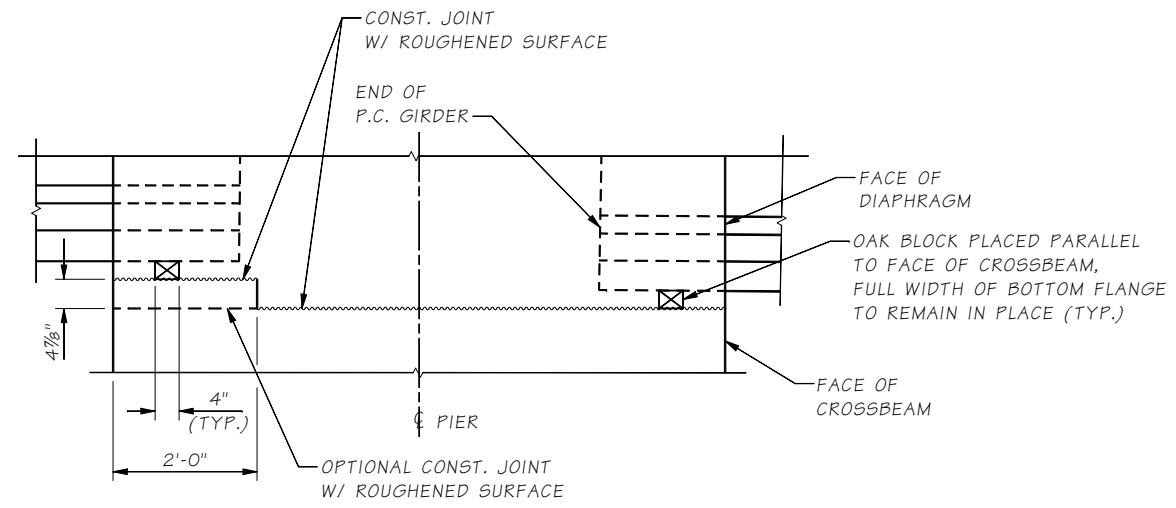

OAK BLOCK DETAIL
 LONGITUDINAL DIMENSIONS ARE NORMAL TO SKEW

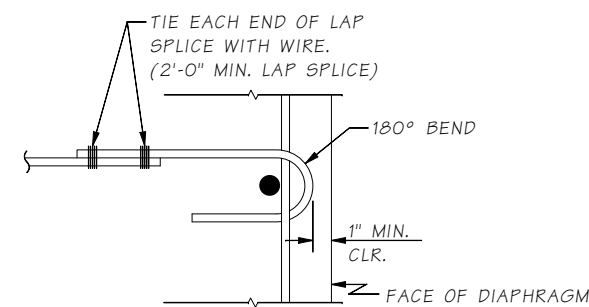

TIE BAR DETAIL

SR 99 FILE NO. SHEET BG102

Bridge Design Engr.	Khaleghi, B	M:\Y-Team\AWV SOUTH INTERCHANGE\window files\Pier 6N X-Beam Dtls 2.WND			
Supervisor	Moore, TM	REGION NO.	STATE	FED. AID PROJ. NO.	SHEET NO.
Designed By	Lee, CS	10	WASH.		TOTAL SHEETS
Checked By	Glassford, P	JOB NUMBER 09A803			
Detailed By	Lemcke, DR				
Bridge Projects Engr.					
Prelim. Plan By					
Architect/Specialist		DATE	REVISION	BY	APPD



BRIDGE AND STRUCTURES OFFICE

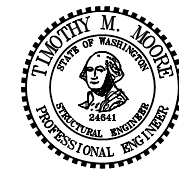

SR 99
ALASKAN WAY VIADUCT - REPLACEMENT
S HOLGATE ST TO S KING ST - PHASE 2
 BRIDGE NO. 99/540 NB & SB
PIER 6N CROSSBEAM DETAILS 2 OF 2

BRIDGE SHEET NO. BG102
 SHEET 948 OF 1475 SHEETS

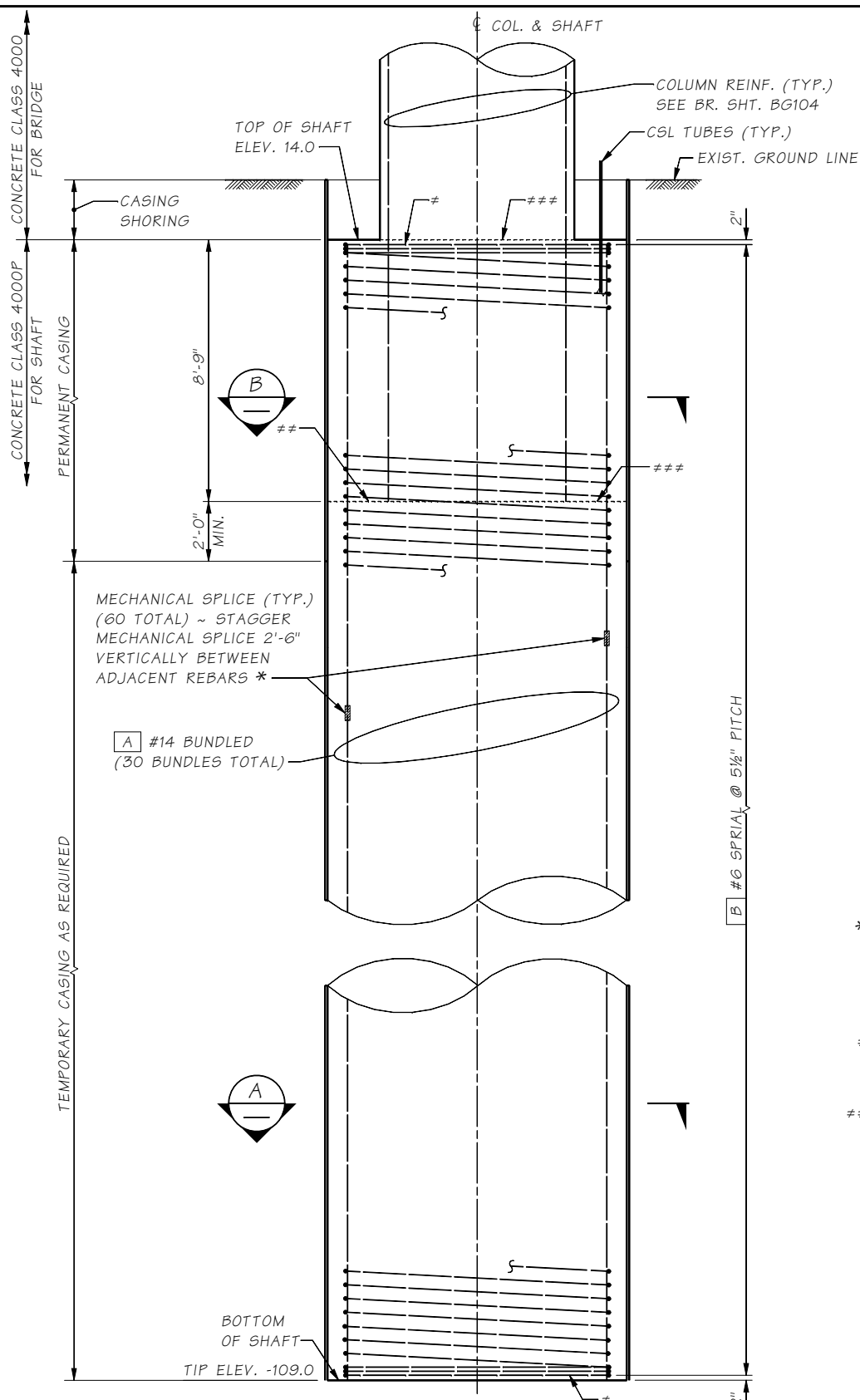

ELEVATION

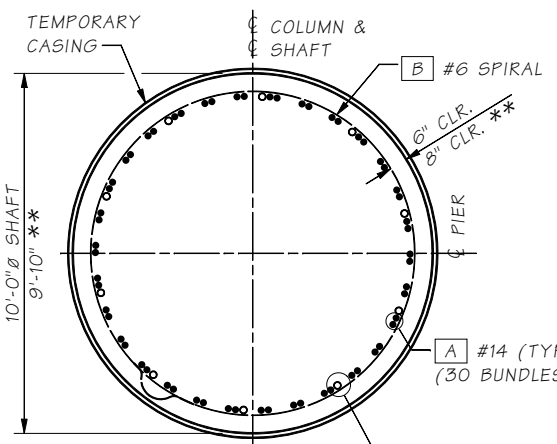

SECTION A

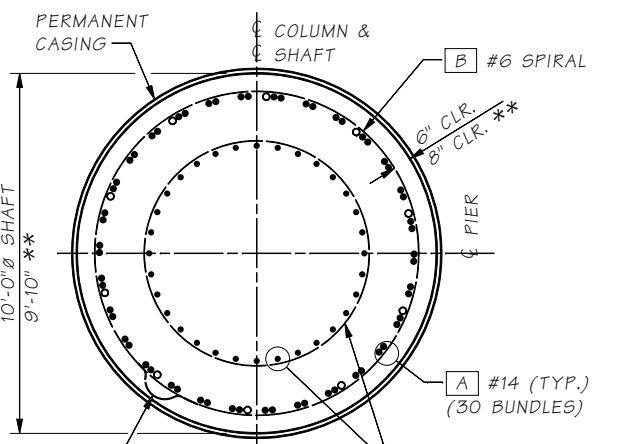

SECTION B

CSL ACCESS TUBES (TYP.) REFER TO SPECIAL PROVISIONS FOR NUMBER, MATERIAL AND INSTALLATION REQUIREMENTS.

SEE SHAFT CENTRALIZER DETAIL THIS SHEET

COLUMN REINF. (TYP.) SEE BR. SHT. BG104

- * MECHANICAL SPLICE SHALL MEET THE REQUIREMENTS OF STD. SPEC. 6-02.3(24)F
- ** SHAFT CONSTRUCTED WITH THE OSCILLATOR METHOD. THE CONTRACTOR SHALL REVISE THE SHAFT BARLIST IF THE OSCILLATOR METHOD IS CHOSEN FOR SHAFT CONSTRUCTION
- # SEE SPIRAL TERMINATION DETAIL THIS SHEET
- ** REMOVE SEDIMENT LAITENCE & WEAK CONCRETE TO SOUND CONCRETE PRIOR TO SETTING COLUMN REINFORCEMENT
- *** CONST. JOINT WITH ROUGHENED SURFACE

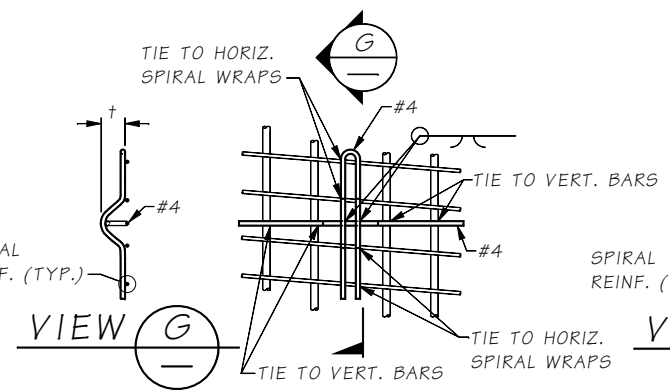

CENTRALIZER DETAIL

EPOXY COAT CENTRALIZER OR PAINT WITH INORGANIC ZINC AFTER FABRICATION (OPTION 1)

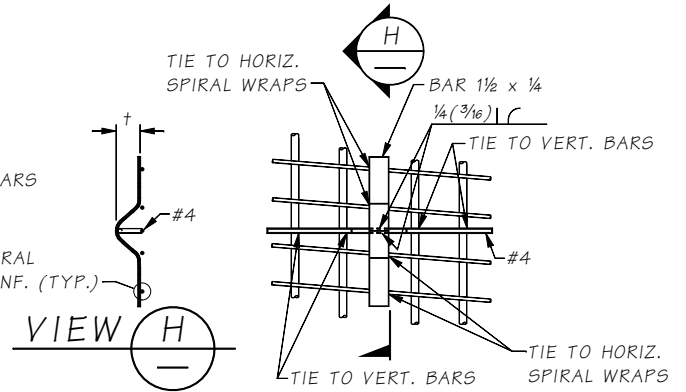

CENTRALIZER DETAIL

EPOXY COAT CENTRALIZER OR PAINT WITH INORGANIC ZINC AFTER FABRICATION (OPTION 2)

- NOTES:
1. EACH LEG SHOULD BE TIED TO TWO VERTICAL BARS OR TWO SPIRALS.
 2. SEE SPECIAL PROVISIONS FOR SPACING REQUIREMENTS.
 3. + CONCRETE COVER MINUS 1/2"

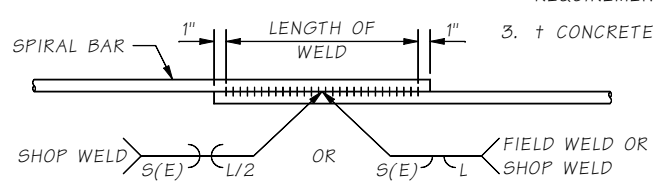

WELDED LAP SPLICE DETAIL

WELDING SHALL MEET THE REQUIREMENTS OF STD. SPEC. 6-02.3(24)E FOR WELD DIMENSIONS SEE TABLE BELOW.

SPIRAL INFORMATION			
DEFORMED BAR ASTM A 706	WELD DEMENSIONS		
	S	E	LENGTH (L)
#6 SPIRAL	3/8"	3/16"	6"

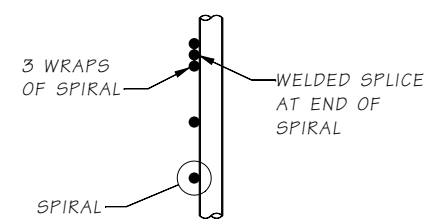

SPIRAL TERMINATION DETAIL

SHAFT BAR LIST

ALL REINFORCING SHALL BE ASTM A 706
QUANTITIES ARE PER SHAFT

MARK	SIZE	NO.	LENGTH	BEND TYPE	WT. (lbs.)
A	#14	60	122'-9"	STR.	56,340
B	#6	1	7599'-0 3/4"	67	11,413
TOTAL					67,753

(a) ~ DETERMINED FROM PLANS
WEIGHT INCLUDES SPLICES
SPIRAL (BEND TYPE 67)

SR 99 FILE NO. SHEET BG103

Bridge Design Engr. Khaleghi, B	M:\Y-Team\AWV SOUTH INTERCHANGE\window files\Pier 1c Shaft Dtl.s.WND	REGION NO.	STATE	FED. AID PROJ. NO.	SHEET NO.	TOTAL SHEETS
Supervisor Moore, TM		10	WASH.			
Designed By Talukdar, M	10/08	JOB NUMBER 09A803				
Checked By Mizumori, A	08/09					
Detailed By Evans, A	10/08					
Bridge Projects Engr.						
Prelim. Plan By						
Architect/Specialist	DATE	REVISION	BY	APPD		



BRIDGE AND STRUCTURES OFFICE

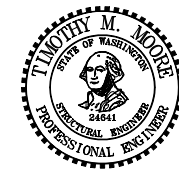

SR 99
ALASKAN WAY VIADUCT - REPLACEMENT
S HOLGATE ST TO S KING ST - PHASE 2
BRIDGE NO. 99/540 NB & SB

PIER 1C SHAFT DETAILS

BRIDGE SHEET NO. BG103
SHEET 949 OF 1475 SHEETS

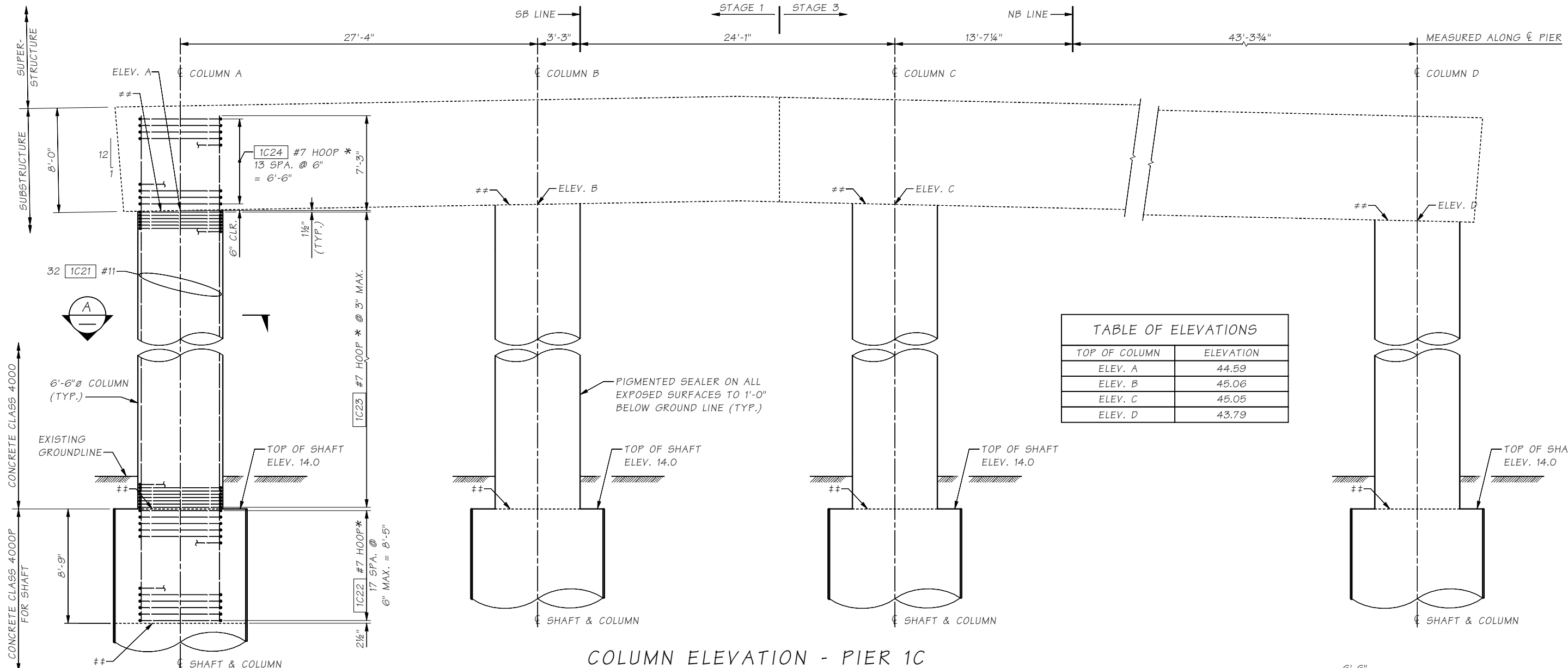

TOP OF COLUMN	ELEVATION
ELEV. A	44.59
ELEV. B	45.06
ELEV. C	45.05
ELEV. D	43.79

COLUMN ELEVATION - PIER 1C

* HOOP WELD SHALL BE DIRECT BUTT-WELDED AND CONFORM TO THE CURRENT EDITION OF STRUCTURAL WELDING CODE - REINFORCING STEEL OF AWS(D1.4) AND MEET THE REQUIREMENTS OF STD. SPEC. 6-02.3(24) RESISTANCE BUTT WELDED SPLICE MAY BE SUBSTITUTED AT THE CONTRACTOR'S OPTION. SEE SPECIAL PROVISIONS.

** CONSTRUCTION JOINT w/ ROUGHENED SURFACE

NOTE:
COLUMN DETAILS & REINFORCING
TYPICAL FOR ALL COLUMNS.

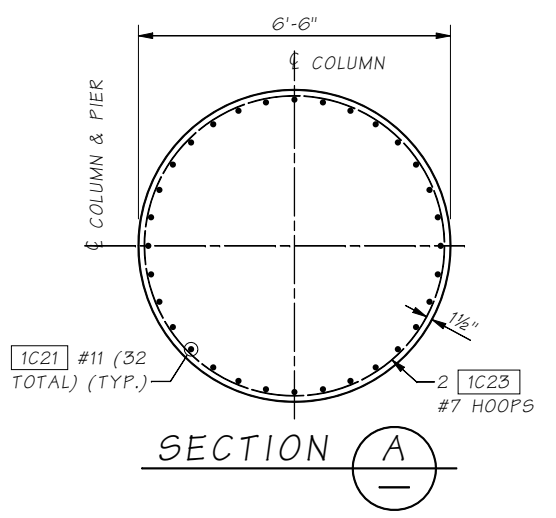
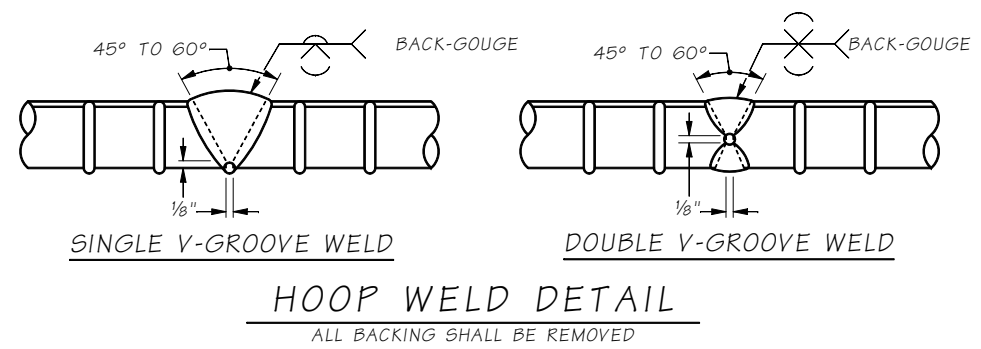

SR 99 FILE NO. SHEET BG104

Bridge Design Engr.	Khaleghi, B	M:\Y-Team\AWV SOUTH INTERCHANGE\window files\Pier 1c Col Dtls 1.WND			
Supervisor	Moore, TM	REGION NO.	STATE	FED. AID PROJ. NO.	SHEET NO.
Designed By	Mizumori, A 10/08	10	WASH.		TOTAL SHEETS
Checked By	Talukdar, M 08/09	JOB NUMBER			
Detailed By	Evans, A 10/08	09A803			
Bridge Projects Engr.		DATE	REVISION	BY	APPD
Prelim. Plan By					
Architect/Specialist					



BRIDGE AND STRUCTURES OFFICE



SR 99
ALASKAN WAY VIADUCT - REPLACEMENT
S HOLGATE ST TO S KING ST - PHASE 2
BRIDGE NO. 99/540 NB & SB

PIER 1C COLUMN DETAILS

BRIDGE SHEET NO. BG104
SHEET 950 OF 1475 SHEETS

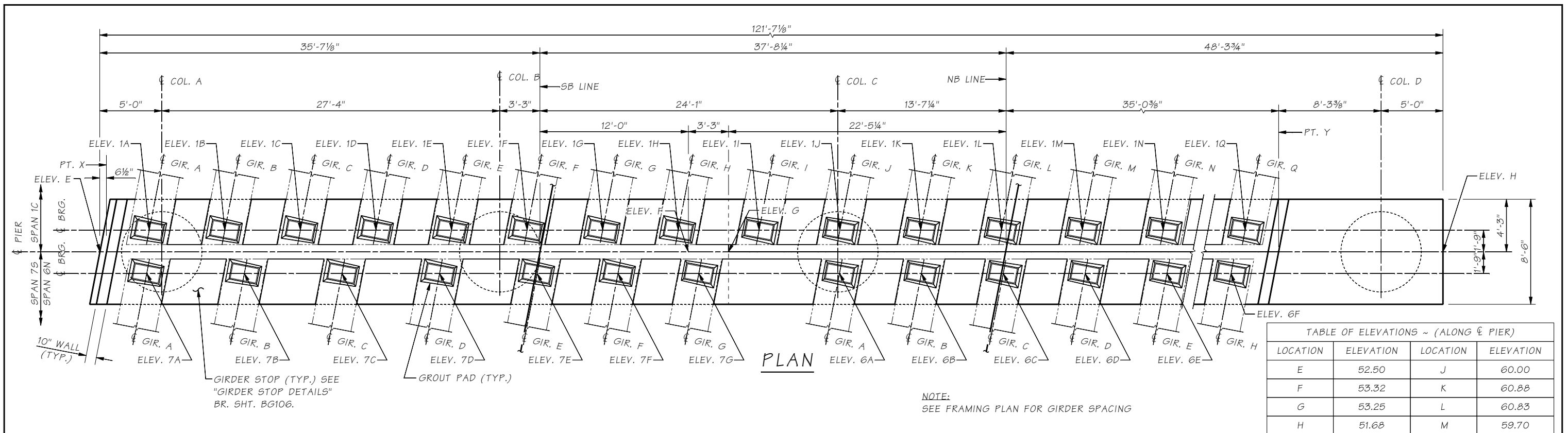
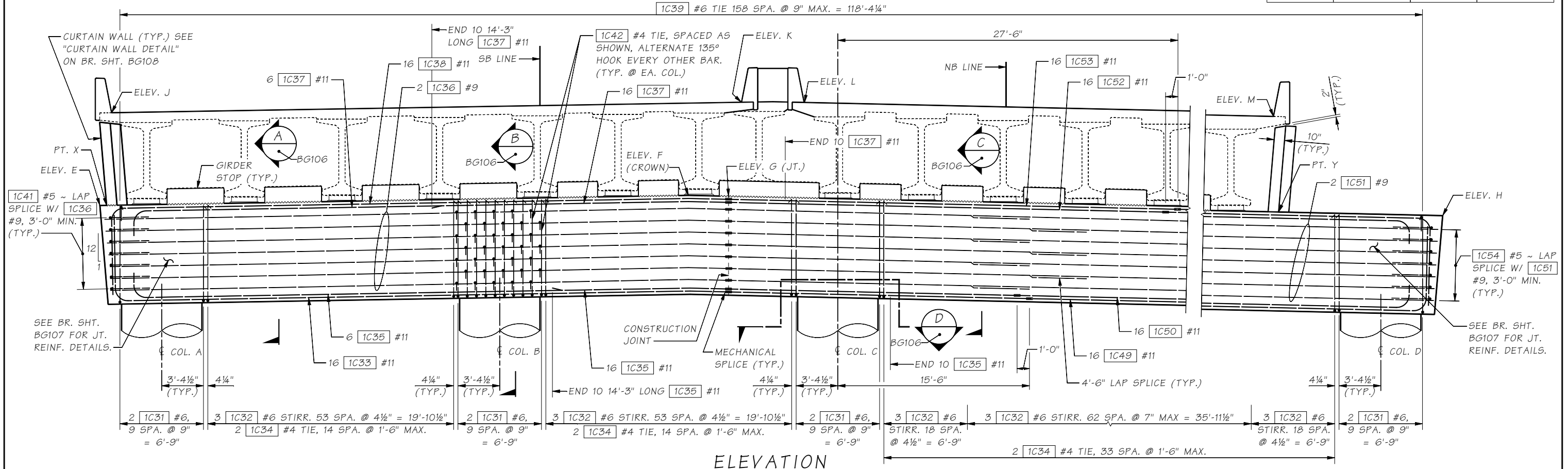

TABLE OF ELEVATIONS ~ (ALONG E PIER)

LOCATION	ELEVATION	LOCATION	ELEVATION
E	52.50	J	60.00
F	53.32	K	60.88
G	53.25	L	60.83
H	51.68	M	59.70



SR 99 FILE NO. SHEET BG105

Bridge Design Engr. Khaleghi, B	M:\Y-Team\AWW SOUTH INTERCHANGE\window files\Pier 1C X-Beam Plan-Elev.WND			
Supervisor Moore, TM	REGION NO.	STATE	FED. AID PROJ. NO.	SHEET NO.
Designed By Mizumori, A 05/09	10	WASH.		
Checked By Rodda, NT 08/09	JOB NUMBER 09A803			
Detailed By Evans, A 05/09				
Bridge Projects Engr.				
Prelim. Plan By				
Architect/Specialist	DATE	REVISION	BY	APPD

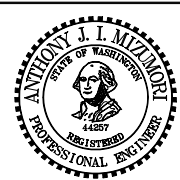

BRIDGE AND STRUCTURES OFFICE

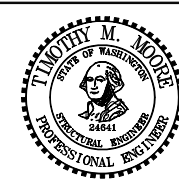

SR 99
ALASKAN WAY VIADUCT - REPLACEMENT
S HOLGATE ST TO S KING ST - PHASE 2
BRIDGE NO. 99/540 NB & SB

PIER 1C CROSSBEAM
PLAN AND ELEVATION

BRIDGE SHEET NO. BG105
SHEET 951 OF 1475 SHEETS

TABLE OF ELEVATIONS @ TOP OF GROUT PADS									
SPAN 7S GIRDERS	7A	7B	7C	7D	7E	7F	7G		
	52.69	52.83	52.96	53.10	53.23	53.35	53.46		
SPAN 6N GIRDERS	6A	6B	6C	6D	6E	6F	6G	6H	
	53.20	53.05	52.91	52.76	52.61	52.47	52.32	52.21	
SPAN 1C GIRDERS (SB)	1A	1B	1C	1D	1E	1F	1G	1H	1I
	52.70	52.81	52.91	53.02	53.12	53.23	53.33	53.44	53.55
SPAN 1C GIRDERS (NB)	1J	1K	1L	1M	1N	1O	1P	1Q	
	53.45	53.31	53.16	53.02	52.87	52.73	52.58	52.44	

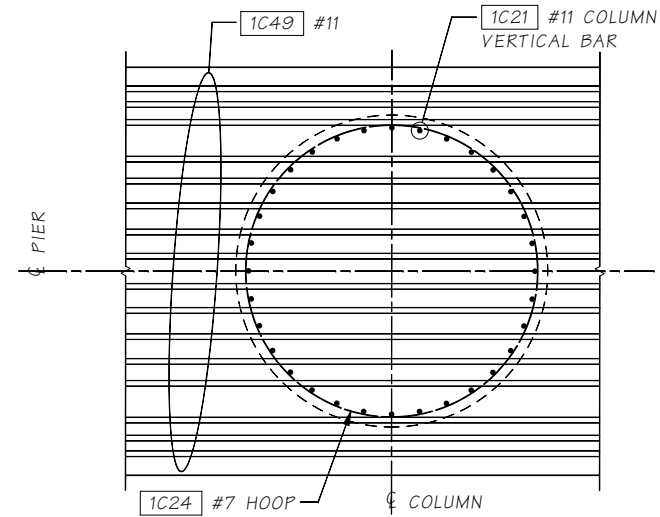

SECTION D
 TRANSVERSE REINFORCING
 NOT SHOWN FOR CLARITY.
 ADJUST LONGITUDINAL BAR,
 TRANSVERSE STIRRUP, AND THE TIE SPACING
 AS REQUIRED TO CLEAR COLUMN VERTICAL BARS.

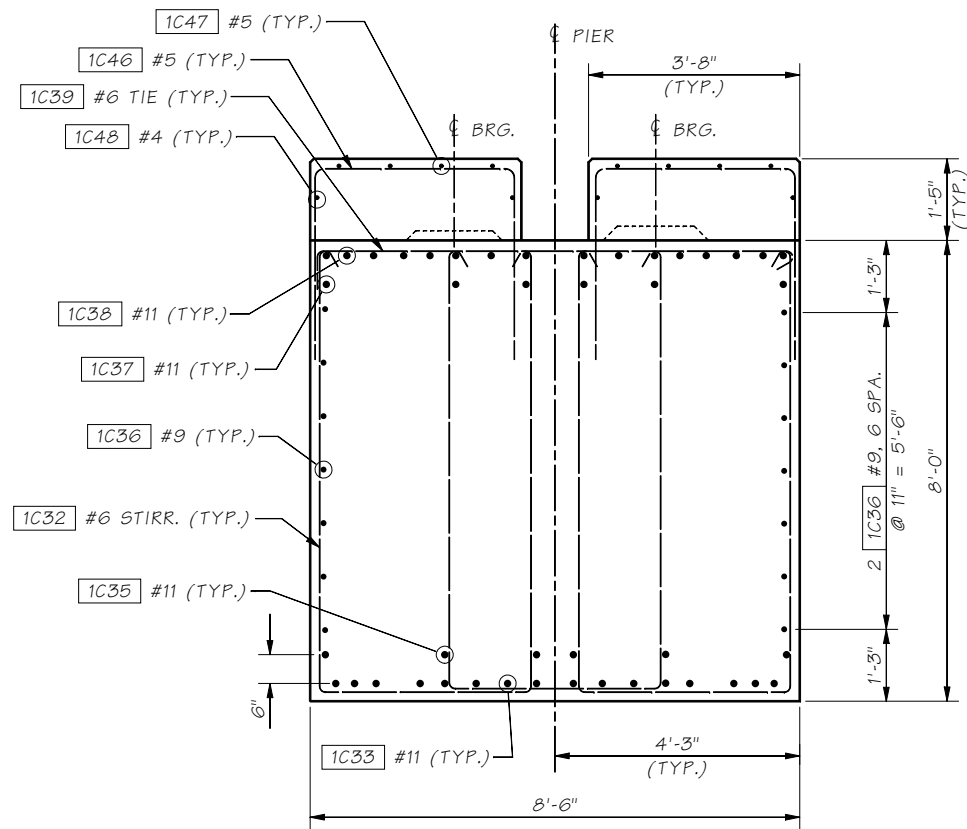

SECTION A
 BG105

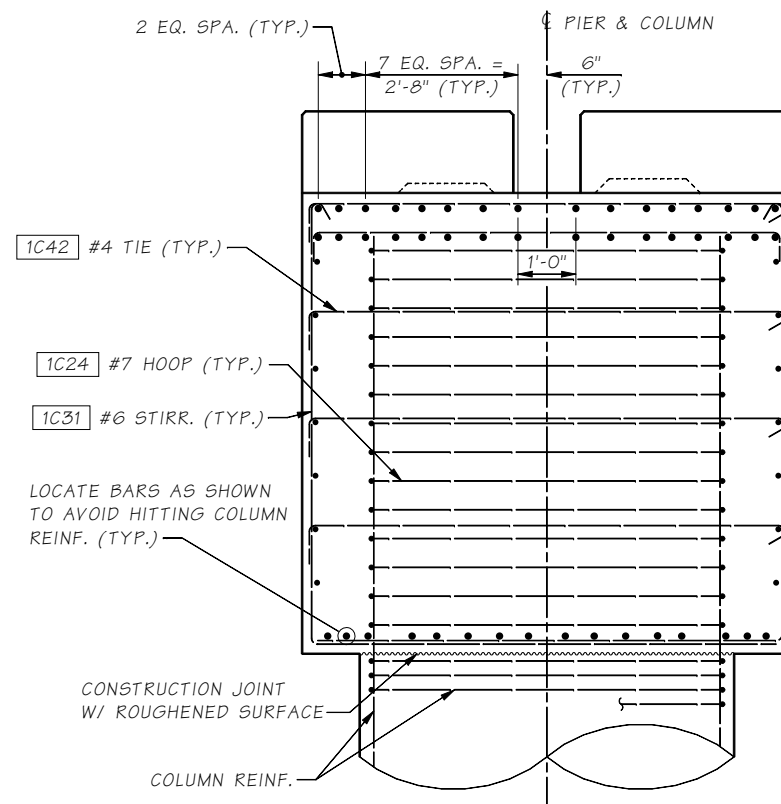

LOCATE BARS AS SHOWN
 TO AVOID HITTING COLUMN
 REINF. (TYP.)

CONSTRUCTION JOINT
 W/ ROUGHENED SURFACE
 COLUMN REINF.

SECTION B
 BG105

SHOWN @ COL. B
 SIMILAR AT OTHER COLUMNS

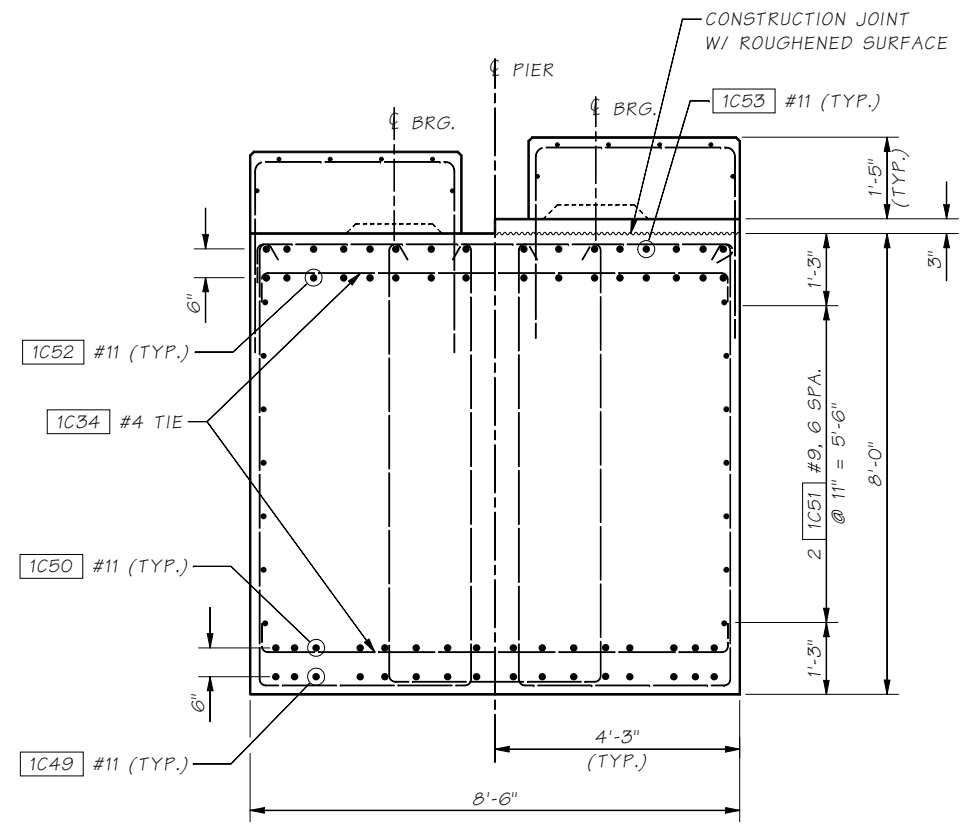

SECTION C
 BG105

SEE SECTION 'A' ON THIS SHEET
 FOR DETAILS NOT SHOWN

SR 99 FILE NO. SHEET BG106

Bridge Design Engr.	Khaleghi, B	M:\Y-Team\AWV SOUTH INTERCHANGE\window files\PIER 1C CROSSBEAM 1.WND				REGION NO.	STATE	FED. AID PROJ. NO.	SHEET NO.	TOTAL SHEETS
Supervisor	Moore, TM					10	WASH.			
Designed By	Mizumori, A	10/08								
Checked By	Rodda, NT	09/09								
Detailed By	Andreotti, L	04/09								
Bridge Projects Engr.										
Prelim. Plan By										
Architect/Specialist		DATE	REVISION	BY	APPD					



BRIDGE
 AND
 STRUCTURES
 OFFICE



SR 99
 ALASKAN WAY VIADUCT - REPLACEMENT
 S HOLGATE ST TO S KING ST - PHASE 2
 BRIDGE NO. 99/540 NB & SB
 PIER 1C CROSSBEAM DETAILS 1 OF 3

BRIDGE SHEET NO.
 BG106
 SHEET
 OF
 1475
 SHEETS

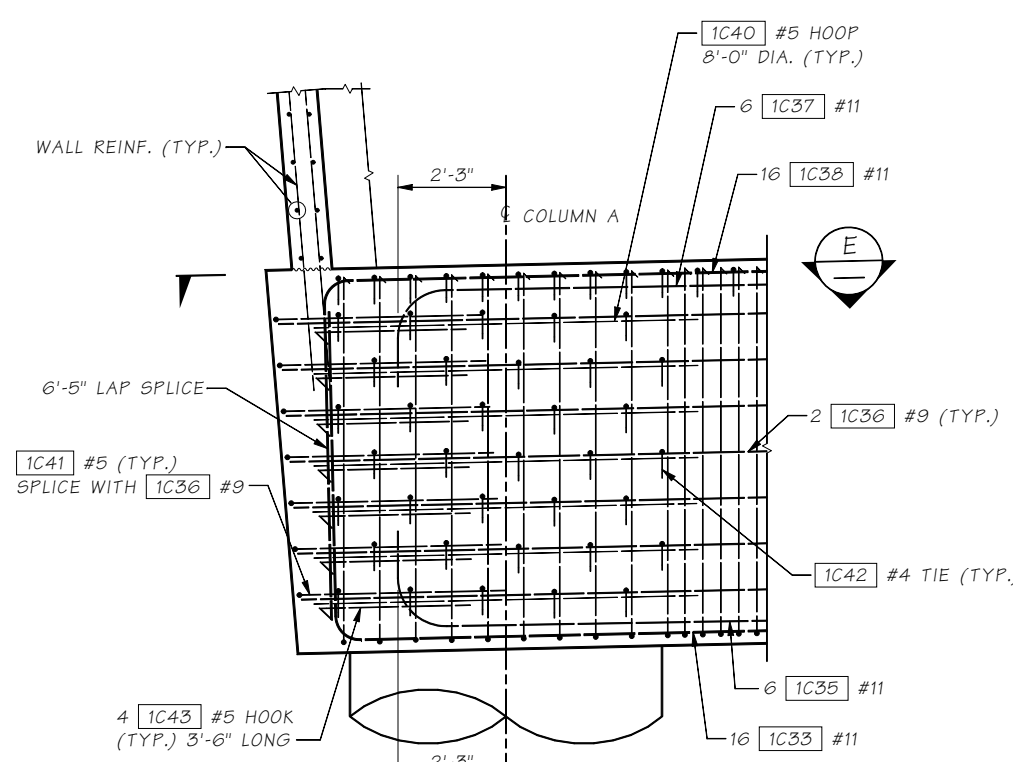

COLUMN A JOINT DETAIL

SEE BR. SHT. BG103 FOR STIRRUPS AND TIES

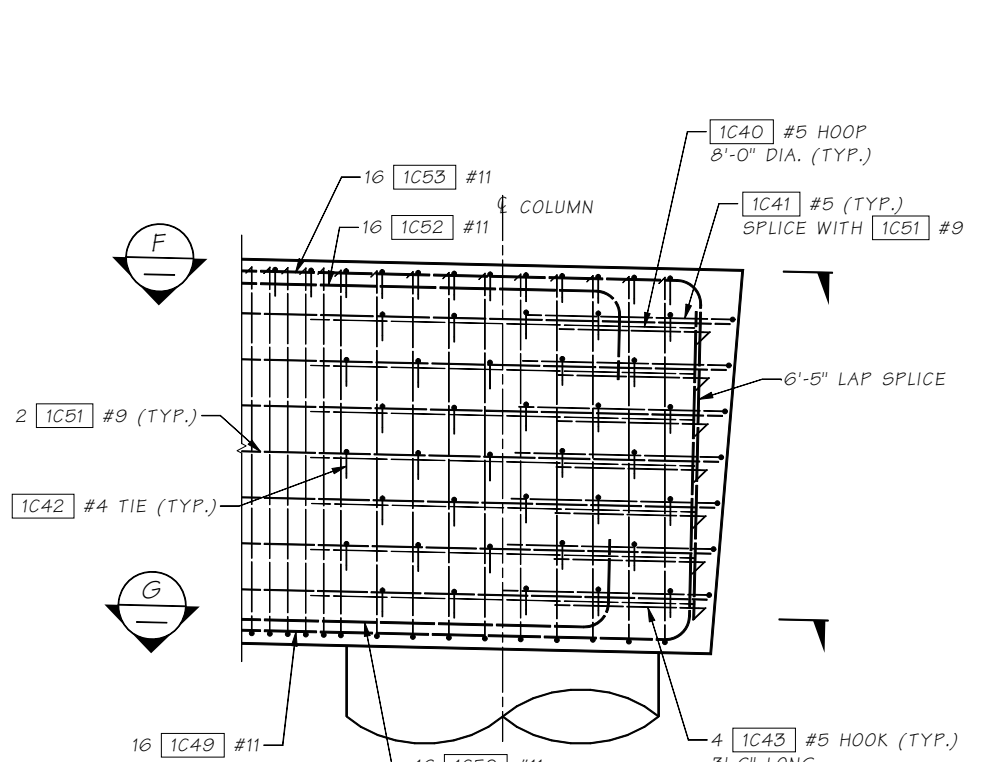

COLUMN D JOINT DETAIL

SEE BR. SHT. BG105 FOR STIRRUPS AND TIES

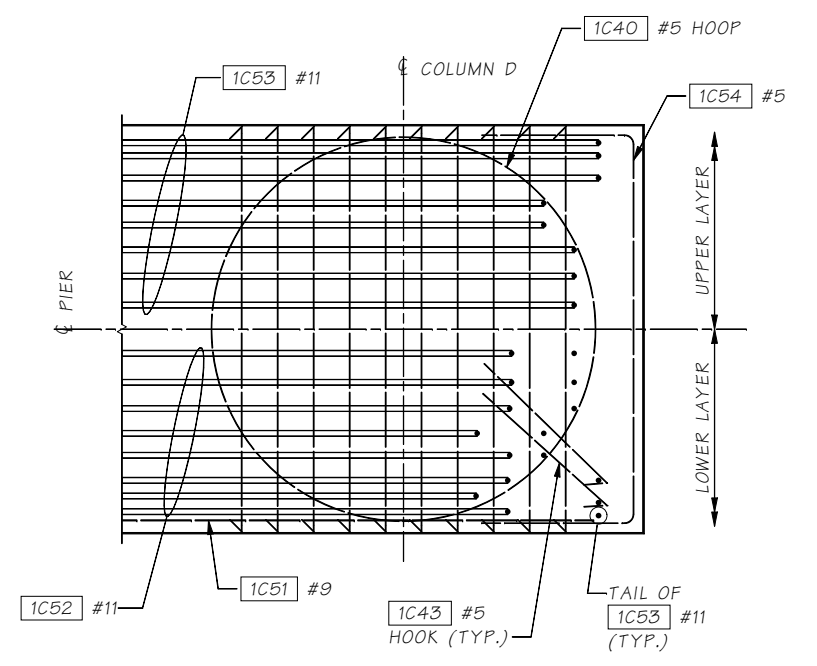

SECTION F
COLUMN D JOINT
TOP MAT REINFORCING

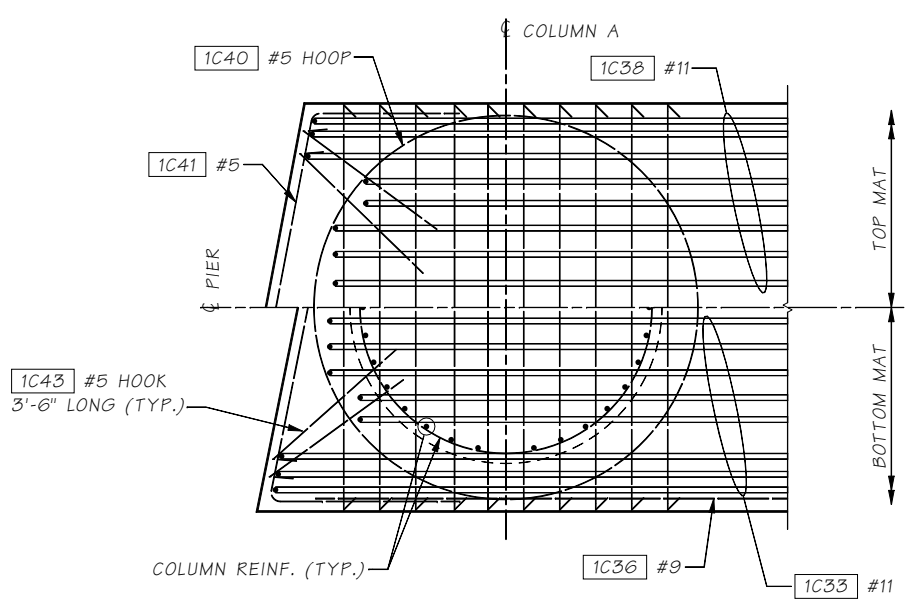

SECTION E
COLUMN A JOINT
WALL REINF. NOT SHOWN

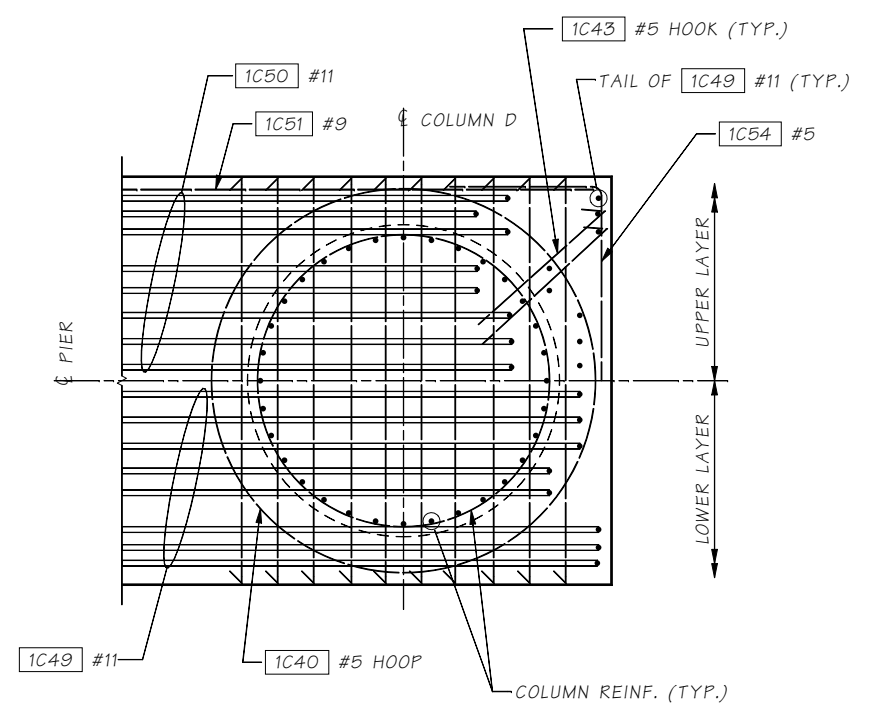

SECTION G
COLUMN D JOINT
BOTTOM MAT REINFORCING

SR 99 FILE NO. SHEET BG107

Bridge Design Engr.	Khaleghi, B	M:\Y-Team\AW SOUTH INTERCHANGE\window files\PIER 1C CROSSBEAM 2.WND				REGION NO.	STATE	FED. AID PROJ. NO.	SHEET NO.	TOTAL SHEETS
Supervisor	Moore, TM									
Designed By	Mizumori, A	10/08			10	WASH.				
Checked By	Rodda, NT	09/09								
Detailed By	Evans, A	10/08								
Bridge Projects Engr.					JOB NUMBER 09A803					
Prelim. Plan By										
Architect/Specialist		DATE	REVISION	BY	APPD					



BRIDGE AND STRUCTURES OFFICE

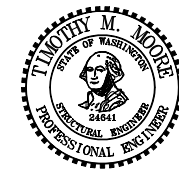

SR 99
ALASKAN WAY VIADUCT - REPLACEMENT
S HOLGATE ST TO S KING ST - PHASE 2
BRIDGE NO. 99/540 NB & SB
PIER 1C CROSSBEAM DETAILS 2 OF 3

BRIDGE SHEET NO. **BG107**
SHEET 953 OF 1475 SHEETS

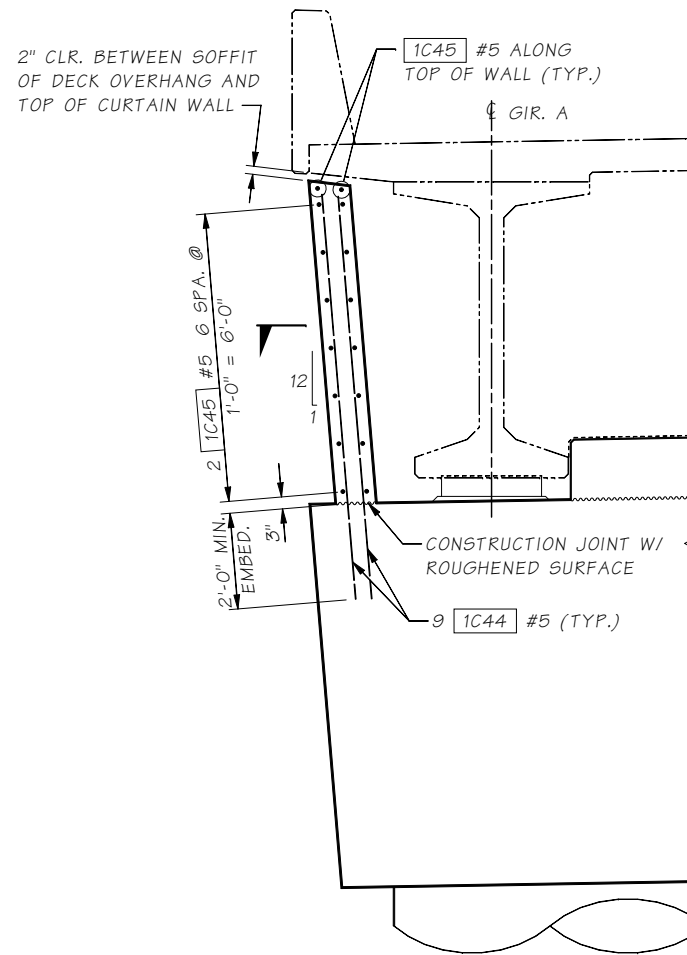

CURTAIN WALL DETAIL
CROSSBEAM REINFORCING NOT SHOWN FOR CLARITY

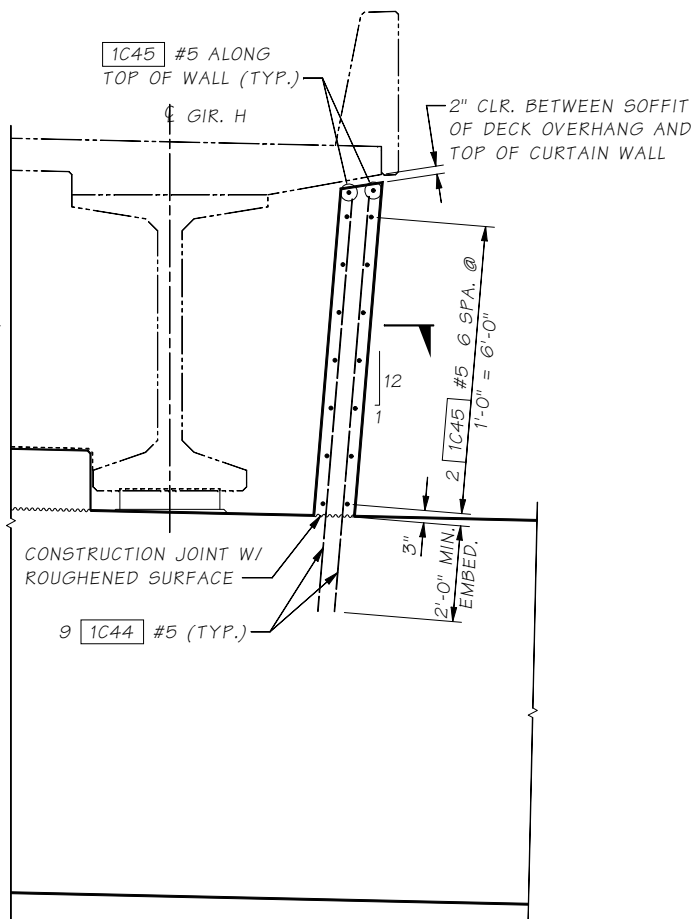

CURTAIN WALL DETAIL
CROSSBEAM REINFORCING NOT SHOWN FOR CLARITY

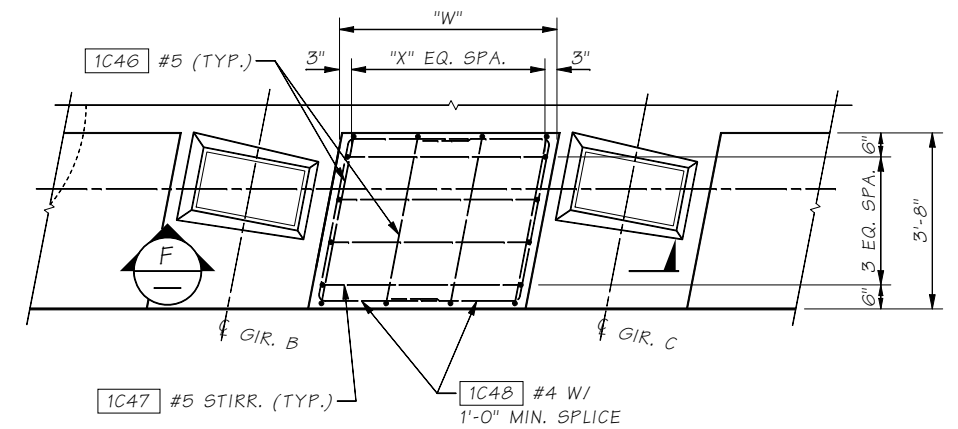

GIRDER STOP DETAIL
SEE "BEARING DETAILS"

LOCATION	"W"	"X"
GIRDERS 7A - 7E (SB)	4'-6 3/8"	4
GIRDERS 7E - 7G (SB)	3'-2"	3
GIRDERS 7G - 6A (SB-NB)	8'-0 1/8"	8
GIRDERS 6A - 6G (NB)	3'-3 1/8"	3
GIRDERS 6G - 6H (NB)	1'-6 3/4"	1
GIRDERS 1A - 1H	2'-9"	3
GIRDERS 1H - 1Q	3'-2"	3

GIRDER STOP TABLE

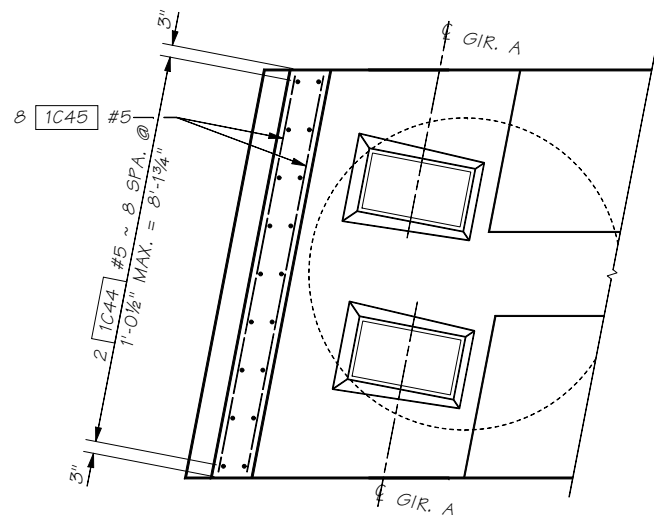

SECTION E

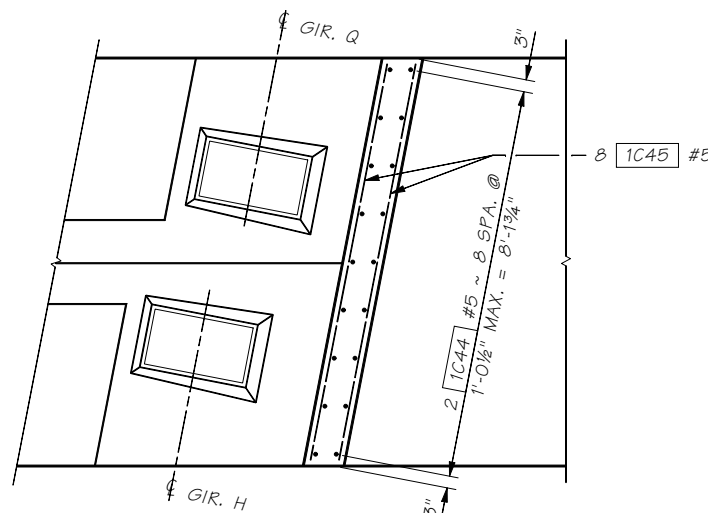

SECTION D

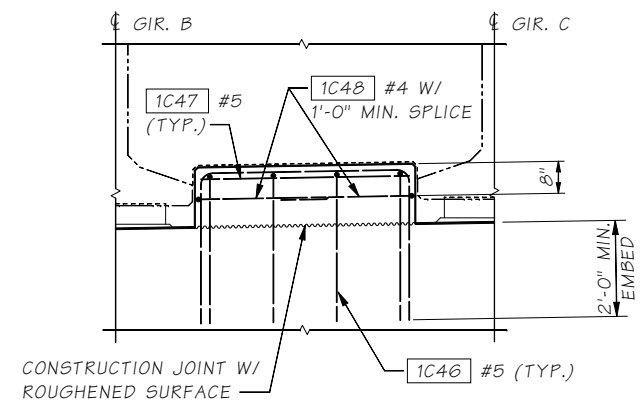

SECTION F

SR 99 FILE NO. SHEET BG108

Bridge Design Engr.	Khaleghi, B	M:\Y-Team\AWV SOUTH INTERCHANGE\window files\PIER 1C CROSSBEAM 3.WND			REGION NO.	STATE	FED. AID PROJ. NO.	SHEET NO.	TOTAL SHEETS
Supervisor	Moore, TM				10	WASH.			
Designed By	Mizumori, A	06/09							
Checked By	Rodda, NT	09/09							
Detailed By	Evans, A	06/09							
Bridge Projects Engr.									
Prelim. Plan By									
Architect/Specialist									
	DATE	REVISION	BY	APPD					



BRIDGE AND STRUCTURES OFFICE

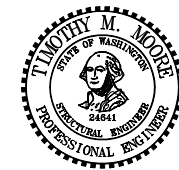

SR 99
ALASKAN WAY VIADUCT - REPLACEMENT
S HOLGATE ST TO S KING ST - PHASE 2
BRIDGE NO. 99/540 NB & SB
PIER 1C CROSSBEAM DETAILS 3 OF 3

BRIDGE SHEET NO. **BG108**
SHEET OF **954**
1475 SHEETS

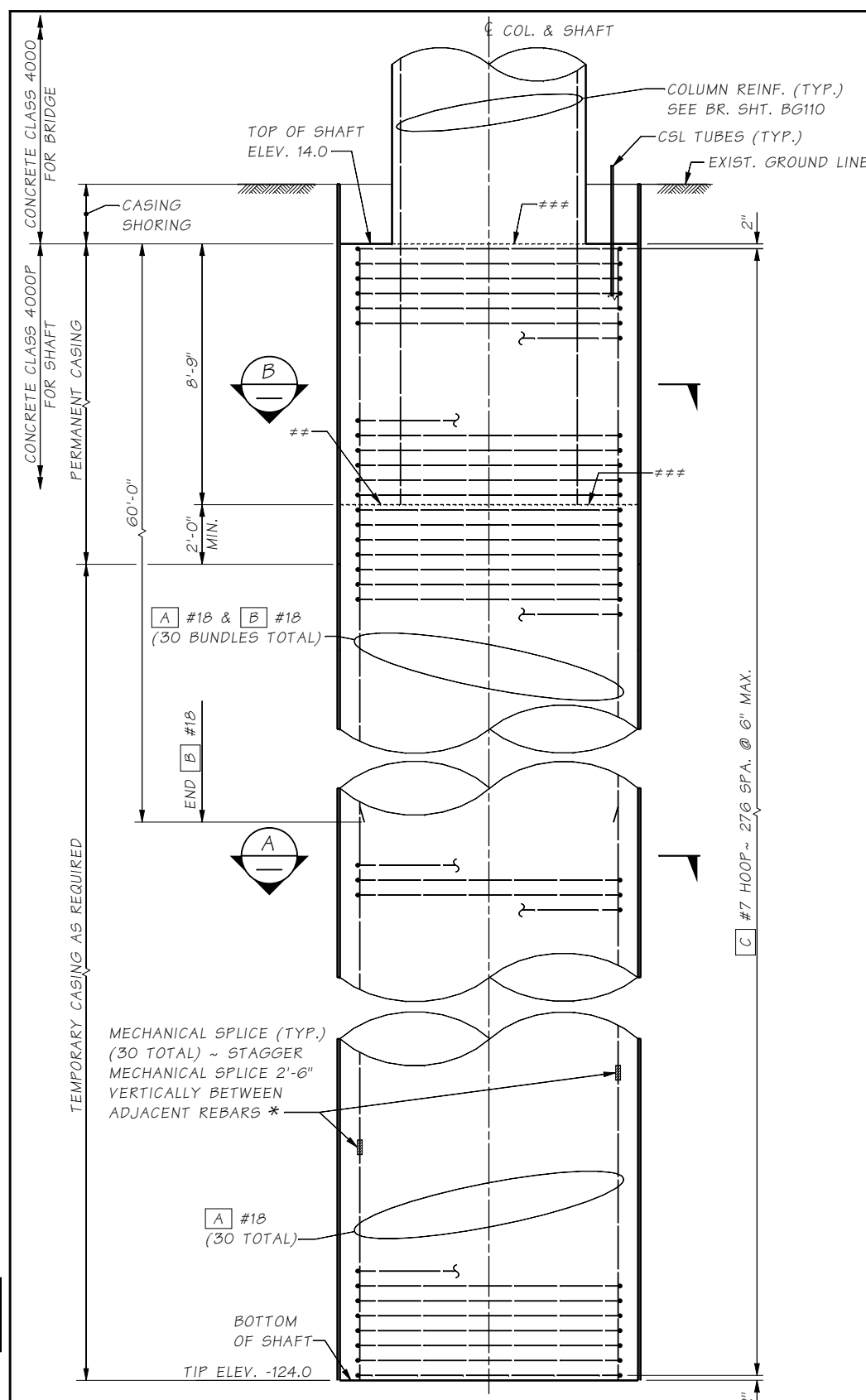

ELEVATION

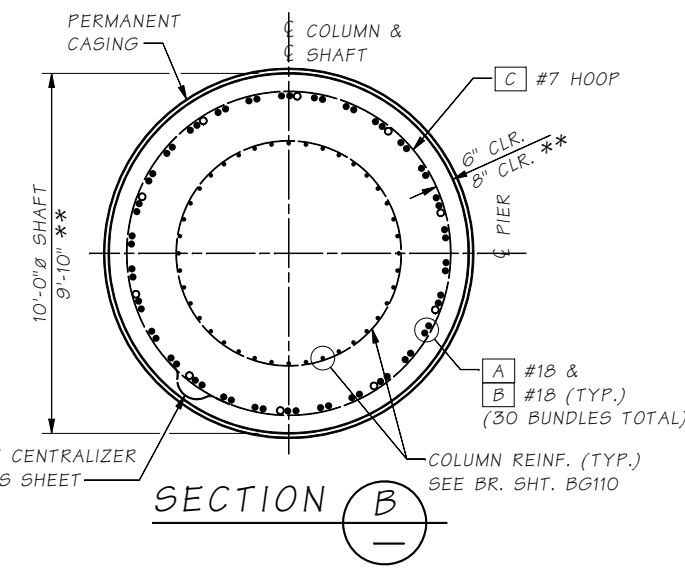
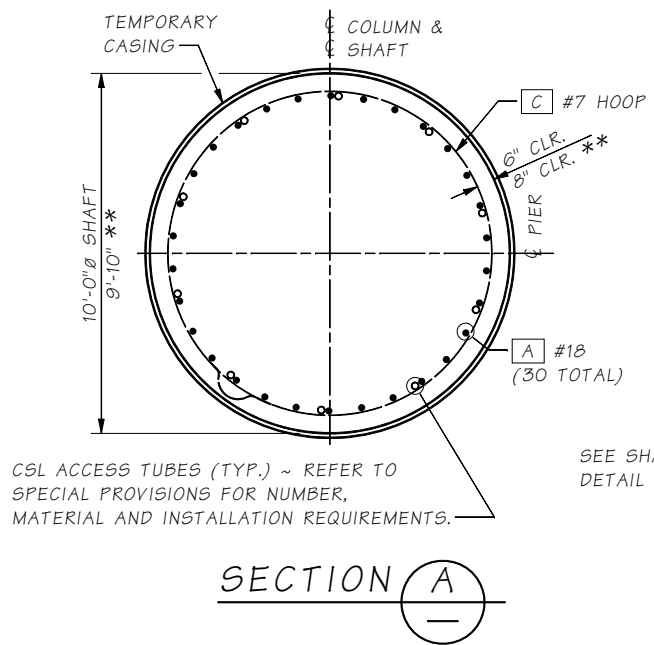

- * MECHANICAL SPLICE SHALL MEET THE REQUIREMENTS OF STD. SPEC. 6-02.3(24)F
- ** SHAFT CONSTRUCTED WITH THE OSCILLATOR METHOD. THE CONTRACTOR SHALL REVISE THE SHAFT BARLIST IF THE OSCILLATOR METHOD IS CHOSEN FOR SHAFT CONSTRUCTION
- ** REMOVE SEDIMENT LAITENCE & WEAK CONCRETE TO SOUND CONCRETE PRIOR TO SETTING COLUMN REINFORCEMENT
- *** CONST. JOINT WITH ROUGHENED SURFACE

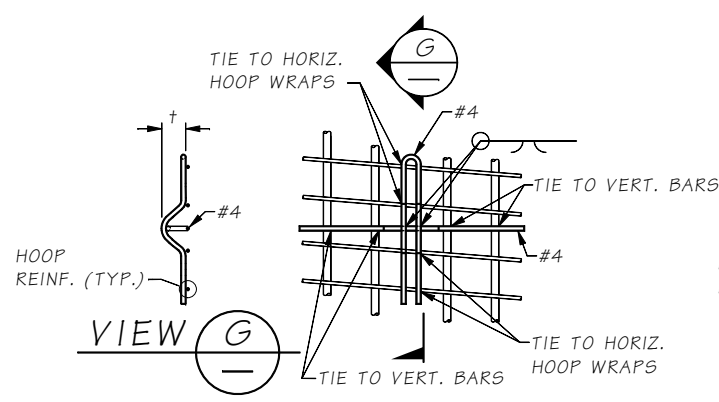

CENTRALIZER DETAIL

EPOXY COAT CENTRALIZER OR PAINT WITH INORGANIC ZINC AFTER FABRICATION (OPTION 1)

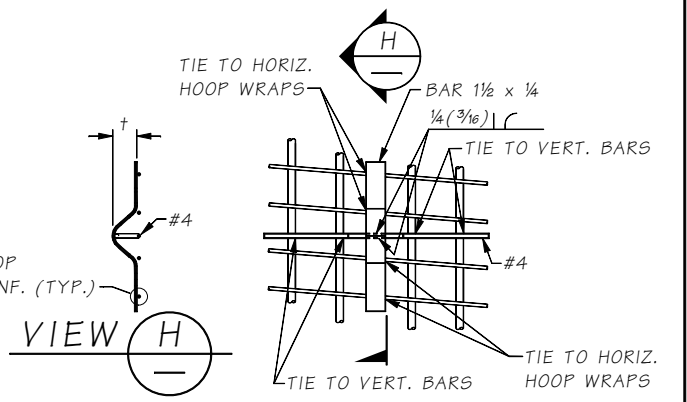

CENTRALIZER DETAIL

EPOXY COAT CENTRALIZER OR PAINT WITH INORGANIC ZINC AFTER FABRICATION (OPTION 2)

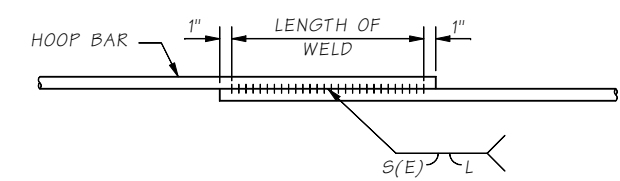

WELDED HOOP SPLICE DETAIL

WELDING SHALL MEET THE REQUIREMENTS OF STD. SPEC. 6-02.3(24)E FOR WELD DIMENSIONS SEE TABLE BELOW. RESISTANCE BUTT WELDED SPLICE MAY BE SUBSTITUTED AT THE CONTRACTOR'S OPTION. SEE SPECIAL PROVISIONS.

SHAFT HOOP INFORMATION			
DEFORMED BAR ASTM A 706	WELD DIMENSIONS (IN.)		
	S	E	LENGTH (L)
#7 HOOP	7/16	1/4	7"

SHAFT BAR LIST

ALL REINFORCING SHALL BE ASTM A 706 QUANTITIES ARE PER SHAFT

MARK	SIZE	NO.	LENGTH	BEND TYPE	WT. (lbs.)
A	#18	30	137'-9"	STR.	56,202
B	#18	30	60'-0"	STR.	24,480
C	#7	277	28'-10"	66	16,305

TOTAL 96,987

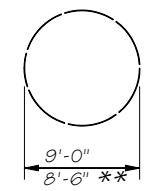

(a) ~ DETERMINED FROM PLANS WEIGHT INCLUDES SPLICES

HOOP (BEND TYPE 66)

NOTES:

1. EACH LEG SHOULD BE TIED TO TWO VERTICAL BARS OR TWO HOOPS.
2. SEE SPECIAL PROVISIONS FOR SPACING REQUIREMENTS.
3. + CONCRETE COVER MINUS 1/2"

SR 99 FILE NO. SHEET BG109

Bridge Design Engr. Khaleghi, B	M:\Y-Team\AWV SOUTH INTERCHANGE\window files\Pier 2c Shaft Dtls.WND	REGION NO.	STATE	FED. AID PROJ. NO.	SHEET NO.	TOTAL SHEETS
Supervisor Moore, TM		10	WASH.			
Designed By Talukdar, M	10/08	JOB NUMBER 09A803				
Checked By Mizumori, A	08/09					
Detailed By Evans, A	10/08					
Bridge Projects Engr.						
Prelim. Plan By						
Architect/Specialist	DATE	REVISION	BY	APPD		



BRIDGE AND STRUCTURES OFFICE

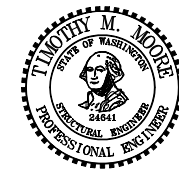

SR 99
ALASKAN WAY VIADUCT - REPLACEMENT
S HOLGATE ST TO S KING ST - PHASE 2
BRIDGE NO. 99/540 NB & SB
PIER 2C SHAFT DETAILS

BRIDGE SHEET NO. BG109
SHEET 955 OF 1475 SHEETS

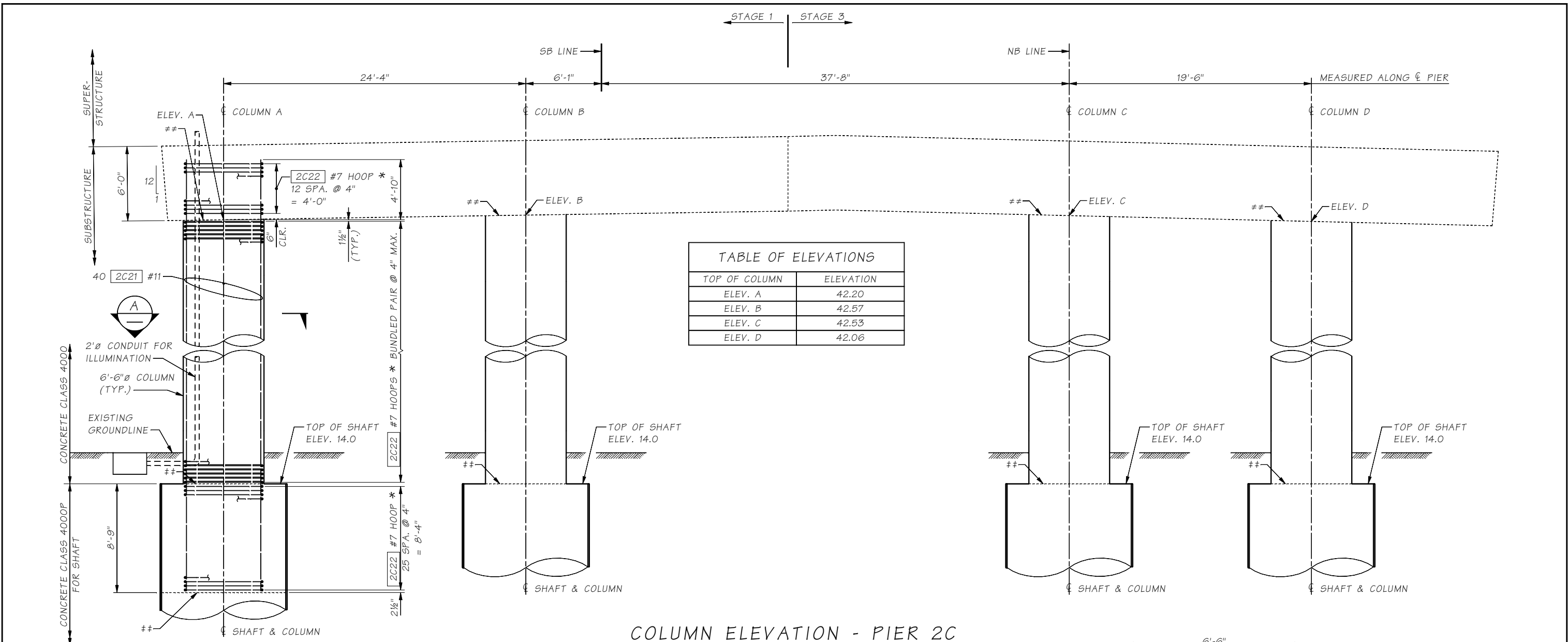

COLUMN ELEVATION - PIER 2C

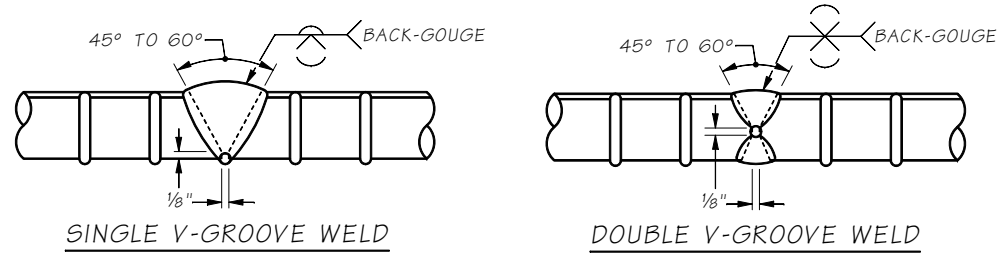

HOOP WELD DETAIL
ALL BACKING SHALL BE REMOVED

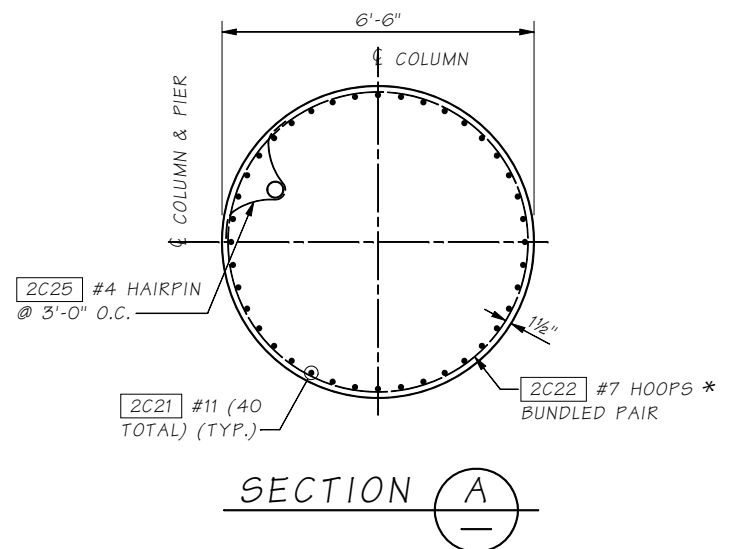

SECTION A

* HOOP WELD SHALL BE DIRECT BUTT-WELDED AND CONFORM TO THE CURRENT EDITION OF STRUCTURAL WELDING CODE - REINFORCING STEEL OF AWS(D1.4) AND MEET THE REQUIREMENTS OF STD. SPEC. 6-02.3(24) RESISTANCE BUTT WELDED SPLICE MAY BE SUBSTITUTED AT THE CONTRACTOR'S OPTION. SEE SPECIAL PROVISIONS.

CONSTRUCTION JOINT w/ ROUGHENED SURFACE

NOTE:
COLUMN DETAILS & REINFORCING TYPICAL FOR ALL COLUMNS.

SR 99 FILE NO. SHEET BG110

Bridge Design Engr.	Khaleghi, B	M:\Y-Team\AWV SOUTH INTERCHANGE\window files\PIER 2C COLUMN.WND	REGION NO.	STATE	FED. AID PROJ. NO.	SHEET NO.	TOTAL SHEETS
Supervisor	Moore, TM		10	WASH.			
Designed By	Mizumori, A	10/08					
Checked By	Talukdar, M	08/09					
Detailed By	Evans, A	10/08					
Bridge Projects Engr.							
Prelim. Plan By							
Architect/Specialist							
	DATE	REVISION	BY	APPD			



BRIDGE AND STRUCTURES OFFICE



SR 99
ALASKAN WAY VIADUCT - REPLACEMENT
S HOLGATE ST TO S KING ST - PHASE 2
BRIDGE NO. 99/540 NB & SB

PIER 2C COLUMN DETAILS

BRIDGE SHEET NO. BG110
SHEET OF 956 OF 1475 SHEETS

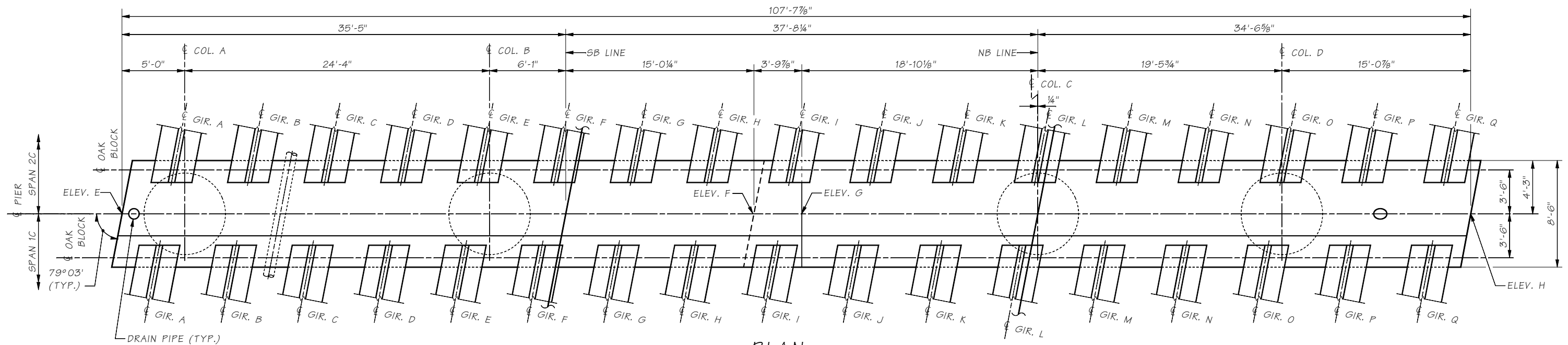

PLAN

SUBSTRUCTURE PORTION OF CROSSBEAM SHOWN

NOTE:
SEE FRAMING PLAN FOR GIRDER SPACING.

TABLE OF ELEVATIONS ~ (ALONG C/PIER)								
LOCATION	E	F	G	H	J	K	L	M
ELEVATION	48.12	48.89	48.98	47.70	57.57	58.37	58.40	57.14

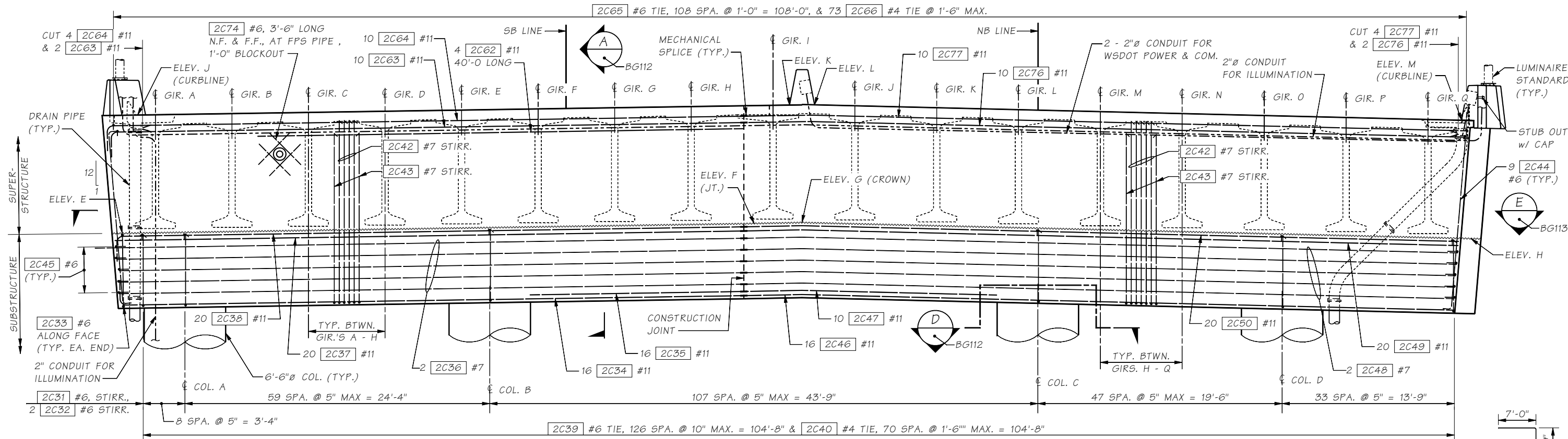

ELEVATION

SEE BR. SHEET BG113 FOR CROSSBEAM END DETAILS AND DETAILS BETWEEN GIRDERS

N.F. = NEAR FACE
F.F. = FAR FACE

SR 99 FILE NO. SHEET BGL11

Bridge Design Engr. Khaleghi, B	M:\Y-Team\AW SOUTH INTERCHANGE\window files\Pier 2c X-Beam Plan-Elev.WND				REGION NO.	STATE	FED. AID PROJ. NO.	SHEET NO.	TOTAL SHEETS
Supervisor Moore, TM					10	WASH.			
Designed By Mizumori, A	05/09								
Checked By Talukdar, M	09/09								
Detailed By Evans, A/L.A.	05/09								
Bridge Projects Engr.									
Prelim. Plan By	2/17/10	REVISED SHEET	CSL	TMM					
Architect/Specialist		REVISION	BY	APPD					



BRIDGE AND STRUCTURES OFFICE

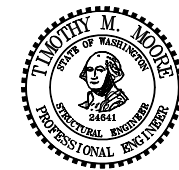

SR 99
ALASKAN WAY VIADUCT - REPLACEMENT
S HOLGATE ST TO S KING ST - PHASE 2
BRIDGE NO. 99/540 NB & SB

PIER 2C CROSSBEAM
PLAN AND ELEVATION

BRIDGE SHEET NO. BG111
SHEET 957 OF 1475 SHEETS

TABLE OF ELEVATIONS @ TOP OF OAK BLOCK

SPAN 1C GIRDERS (SB)	1A	1B	1C	1D	1E	1F	1G	1H	1I
	48.59	48.68	48.77	48.87	48.96	49.06	49.15	49.24	49.34
SPAN 1C GIRDERS (NB)	1J	1K	1L	1M	1N	1O	1P	1Q	
	49.28	49.12	48.96	48.81	48.65	48.49	48.34	48.18	
SPAN 2C GIRDERS (SB)	2A	2B	2C	2D	2E	2F	2G	2H	2I
	48.43	48.52	48.61	48.71	48.80	48.89	48.99	49.08	49.18
SPAN 2C GIRDERS (NB)	2J	2K	2L	2M	2N	2O	2P	2Q	
	49.11	48.96	48.80	48.64	48.48	48.33	48.17	48.01	

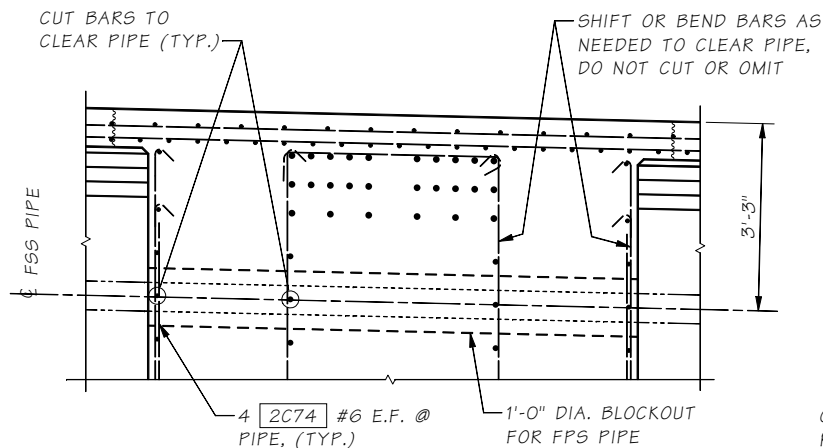

PIPE DETAIL

SECTION TAKEN BETWEEN GIRS. B AND C

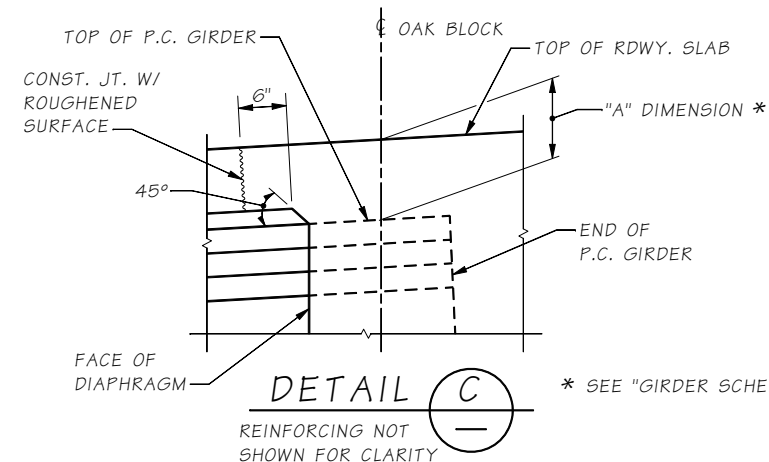

DETAIL C

* SEE "GIRDER SCHEDULE" SHEETS

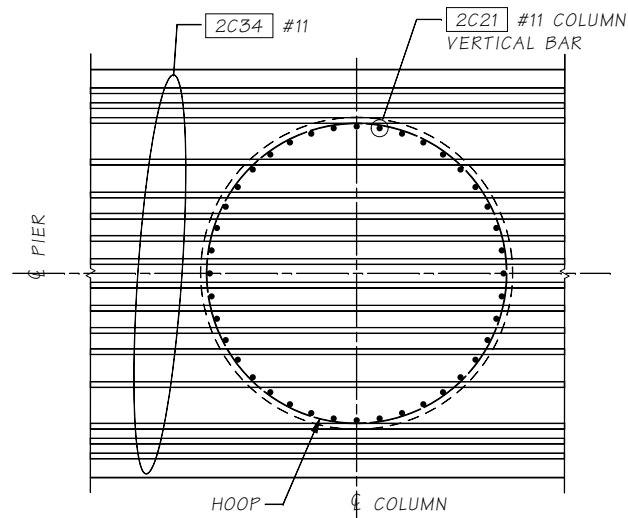

SECTION D

TRANSVERSE REINFORCING NOT SHOWN FOR CLARITY. ADJUST LONGITUDINAL BAR, TRANSVERSE STIRRUP, AND THE TIE SPACING AS REQUIRED TO CLEAR COLUMN VERTICAL BARS.

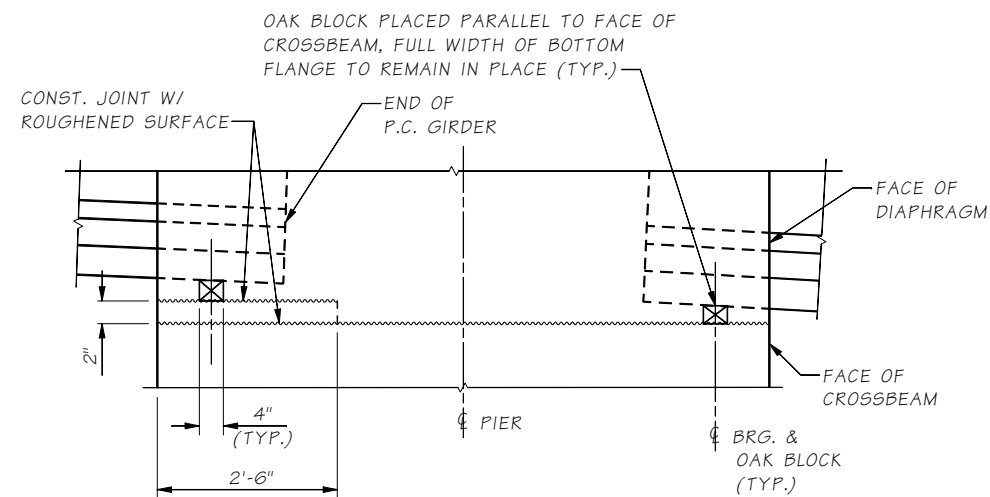

OAK BLOCK DETAIL

LONGITUDINAL DIMENSIONS ARE NORMAL TO PIER

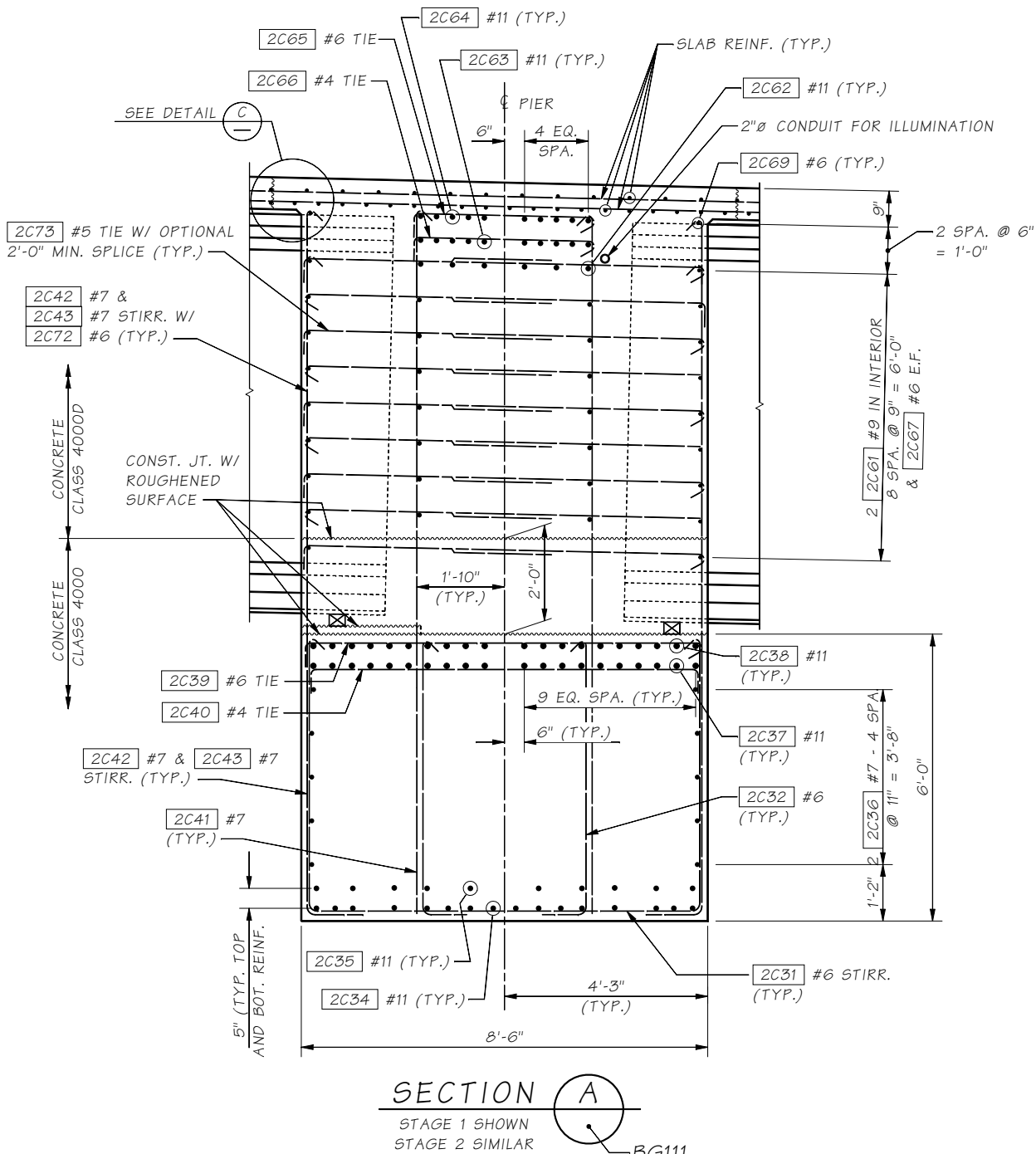

SECTION A

STAGE 1 SHOWN
STAGE 2 SIMILAR

SR 99 FILE NO. SHEET BGL12

Bridge Design Engr. Khaleghi, B	M:\Y-Team\AWV SOUTH INTERCHANGE\window files\PIER 2C CROSSBEAM 1.WND				REGION NO.	STATE	FED. AID PROJ. NO.	SHEET NO.	TOTAL SHEETS
Supervisor Moore, TM					10	WASH.			
Designed By Mizumori, A	10/08				JOB NUMBER 09A803				
Checked By Talukdar, M	09/09								
Detailed By Andreotti, L	04/09								
Bridge Projects Engr.									
Prelim. Plan By									
Architect/Specialist	DATE	REVISION	BY	APPD					

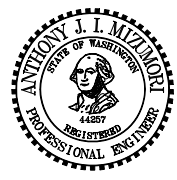

BRIDGE AND STRUCTURES OFFICE

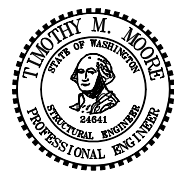

SR 99
ALASKAN WAY VIADUCT - REPLACEMENT
S HOLGATE ST TO S KING ST - PHASE 2
BRIDGE NO. 99/540 NB & SB
PIER 2C CROSSBEAM DETAILS 1 OF 2

BRIDGE SHEET NO. BGL12
SHEET 958 OF 1475 SHEETS

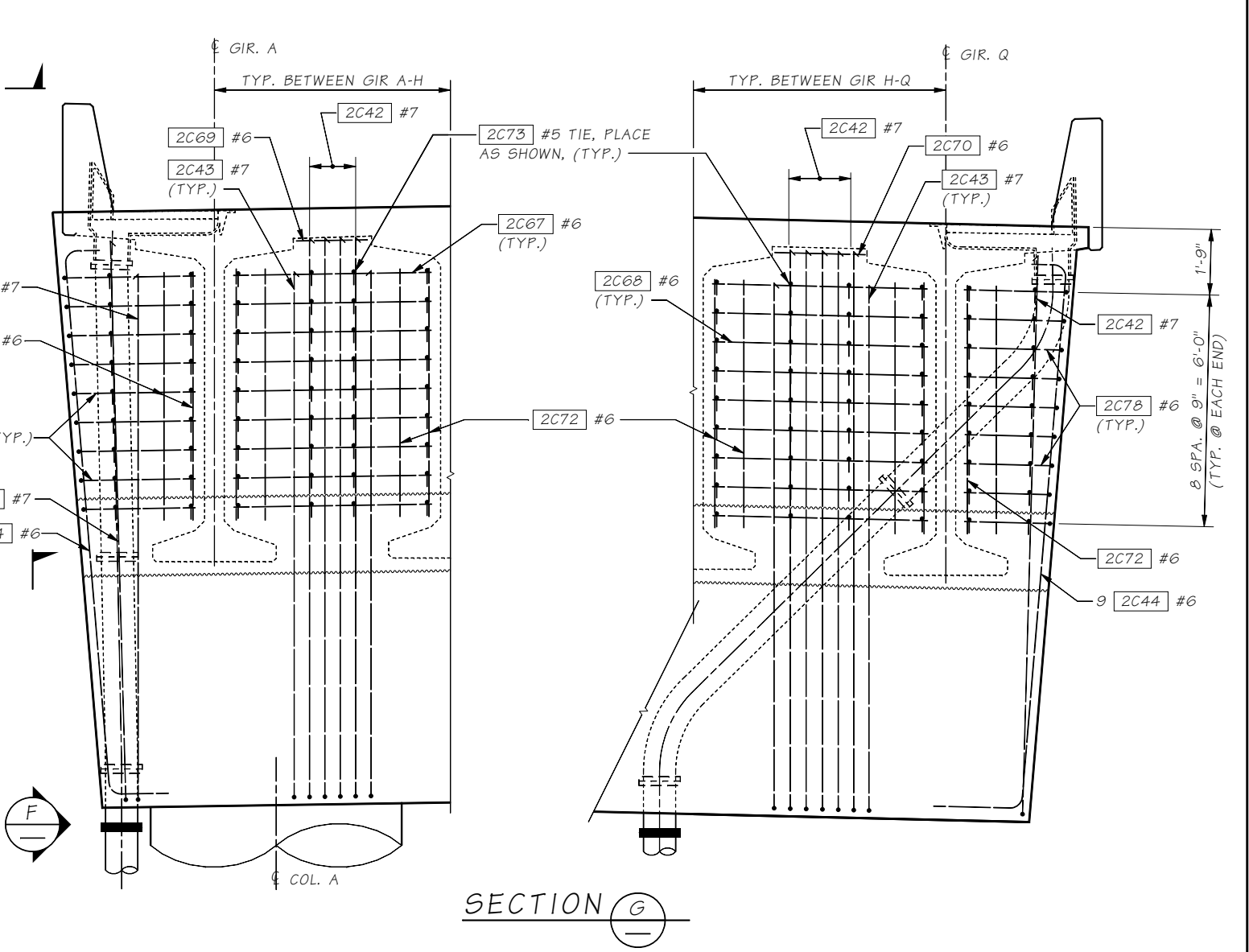
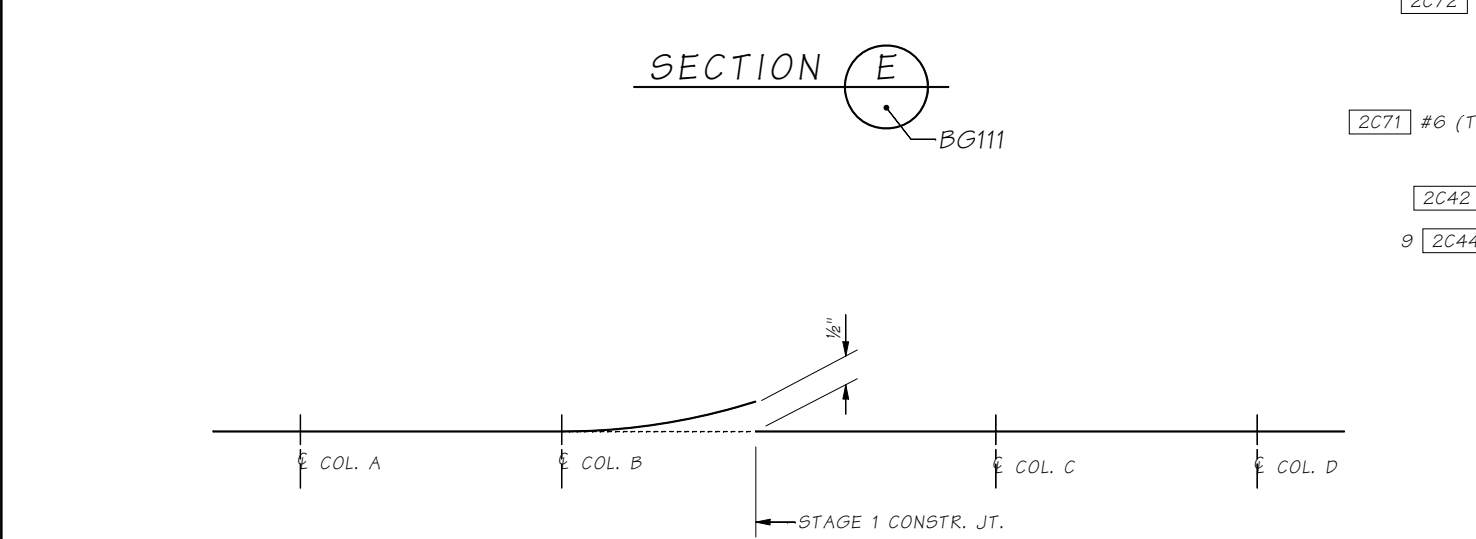
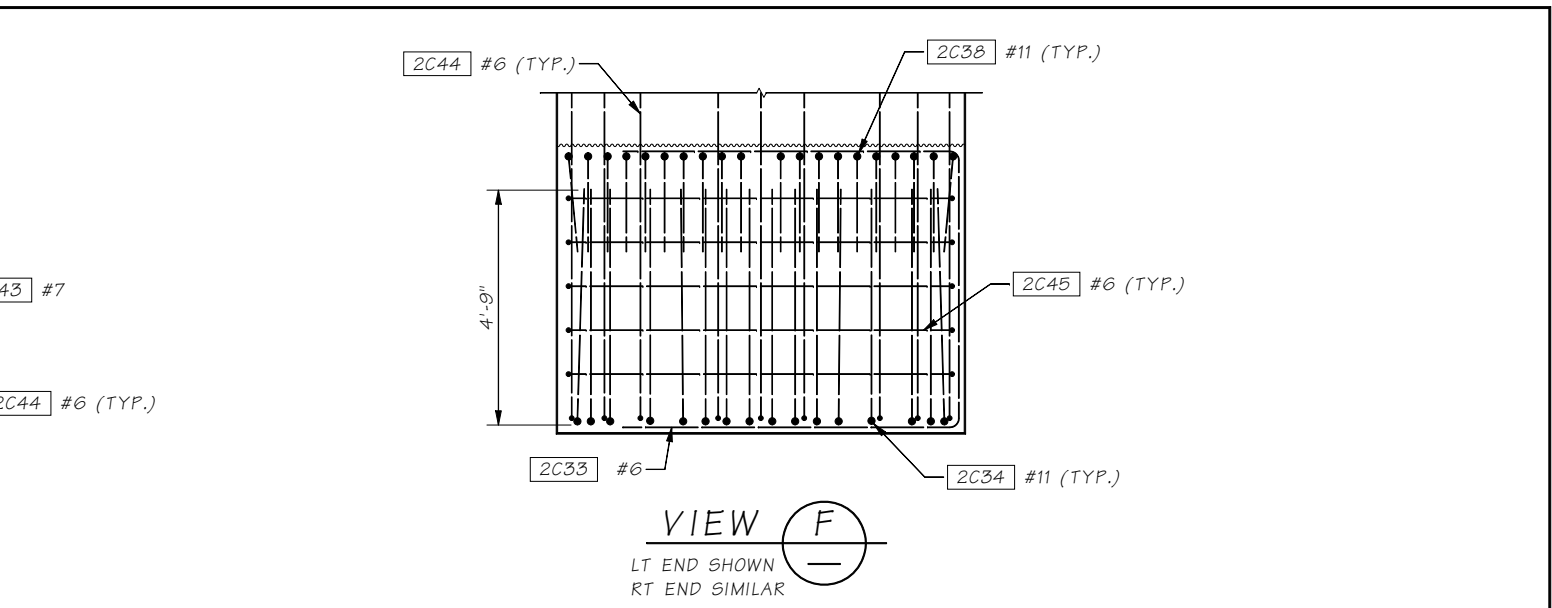
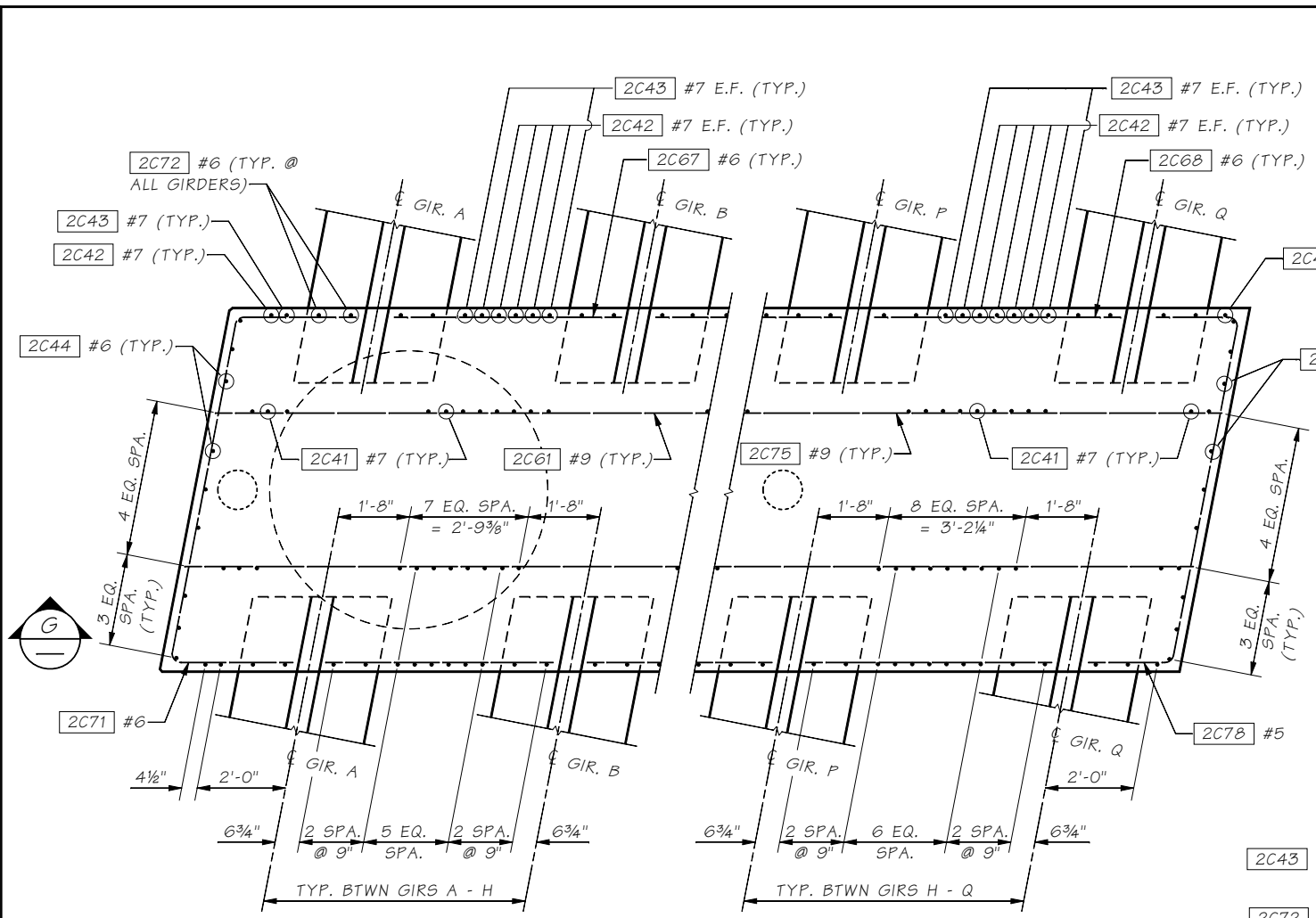

LOWER CROSSBEAM CAMBER DIAGRAM

THE LOWER PORTION OF THE STAGE 1 CROSSBEAM SHALL BE CAMBERED TO COMPENSATE FOR DEAD LOAD DEFLECTION ASSOCIATED WITH GIRDER, DIAPHRAGM, AND DECK WEIGHT. IN ADDITION, FALSEWORK DEFLECTIONS AT THE STAGE 1 CONSTRUCTION JOINT SHALL BE COMPENSATED FOR.

SR 99 FILE NO. SHEET BGL13

Bridge Design Engr.	Khaleghi, B	M:\Y-Team\AWV SOUTH INTERCHANGE\window files\PIER 2C CROSSBEAM 2.WND			
Supervisor	Moore, TM	REGION NO.	STATE	FED. AID PROJ. NO.	SHEET NO.
Designed By	Mizumori, A 10/08	10	WASH.		TOTAL SHEETS
Checked By	Talukdar, M 09/09	JOB NUMBER 09A803			
Detailed By	Evans, A 10/08				
Bridge Projects Engr.					
Prelim. Plan By					
Architect/Specialist		DATE	REVISION	BY	APPD

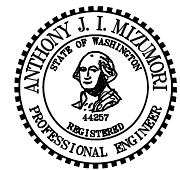

BRIDGE AND STRUCTURES OFFICE

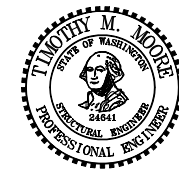

SR 99
ALASKAN WAY VIADUCT - REPLACEMENT
S HOLGATE ST TO S KING ST - PHASE 2
BRIDGE NO. 99/540 NB & SB
PIER 2C CROSSBEAM DETAILS 2 OF 2

BRIDGE SHEET NO. BGL13
SHEET 959 OF 1475 SHEETS

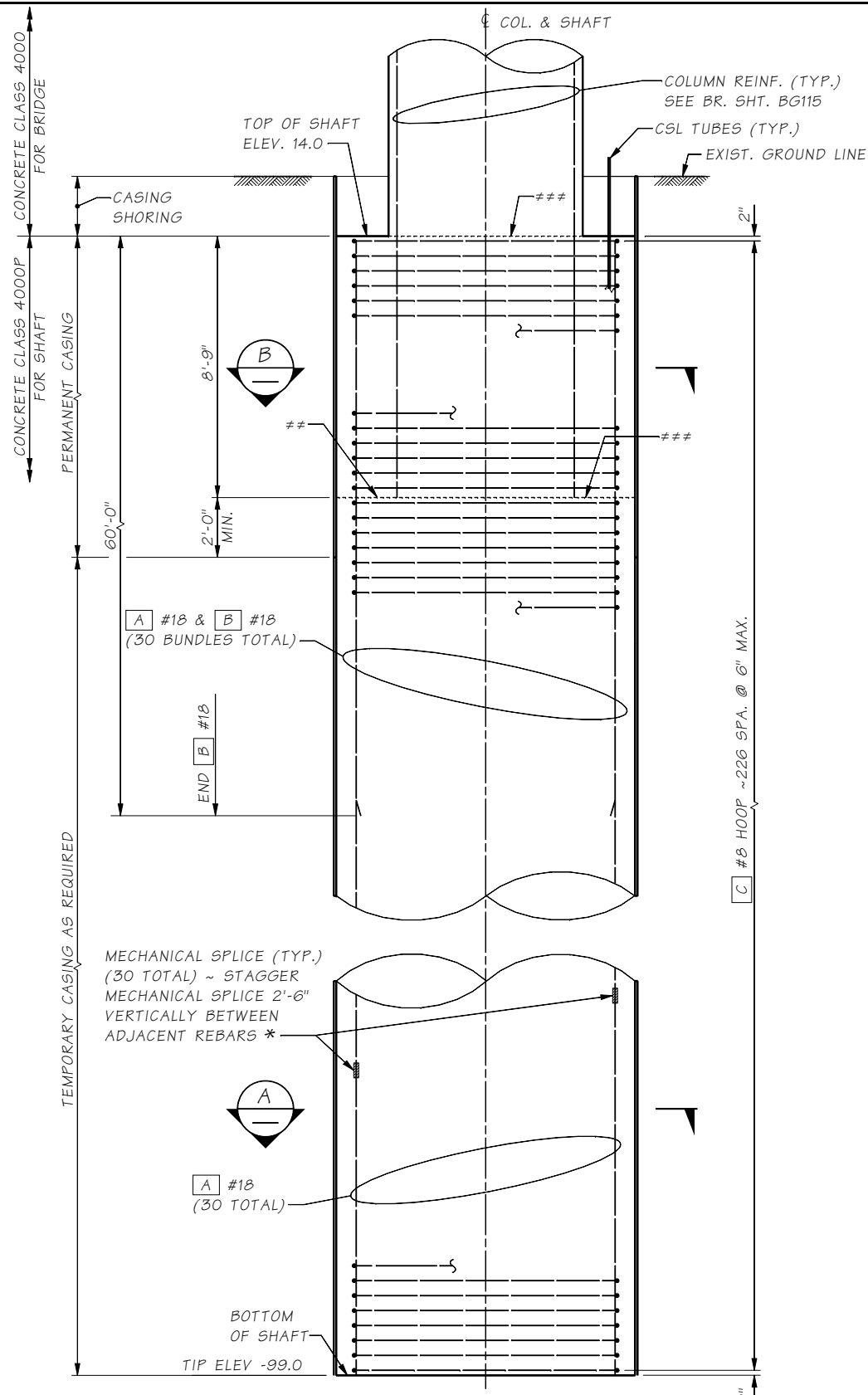

ELEVATION

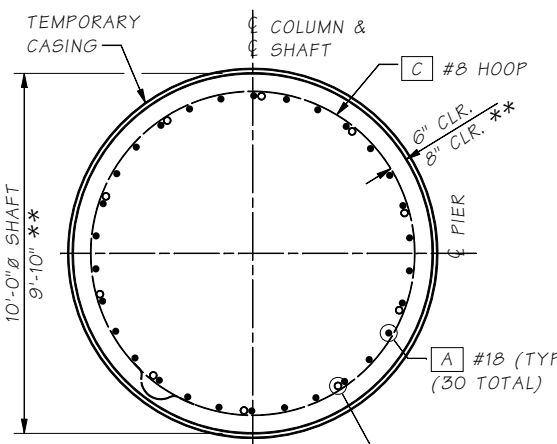

SECTION A

CSL ACCESS TUBES (TYP.). REFER TO SPECIAL PROVISIONS FOR NUMBER, MATERIAL AND INSTALLATION REQUIREMENTS.

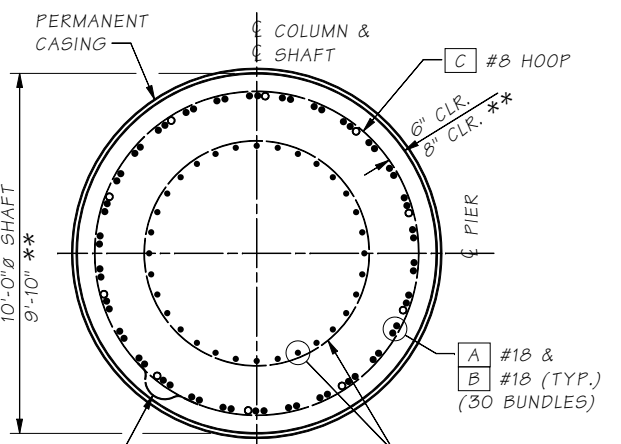

SECTION B

SEE SHAFT CENTRALIZER DETAIL THIS SHEET

COLUMN REINF. (TYP.) SEE BR. SHT. BG115

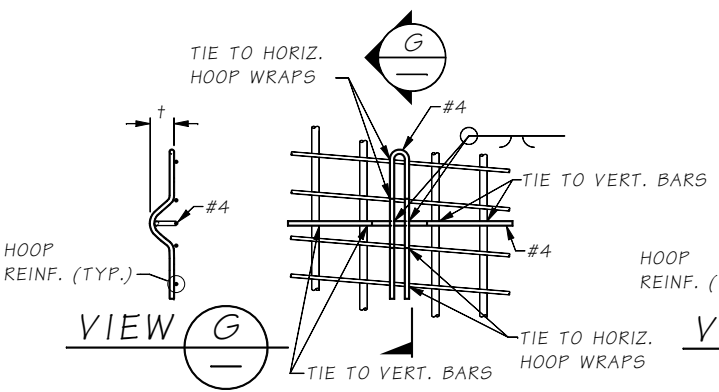

CENTRALIZER DETAIL

EPOXY COAT CENTRALIZER OR PAINT WITH INORGANIC ZINC AFTER FABRICATION (OPTION 1)

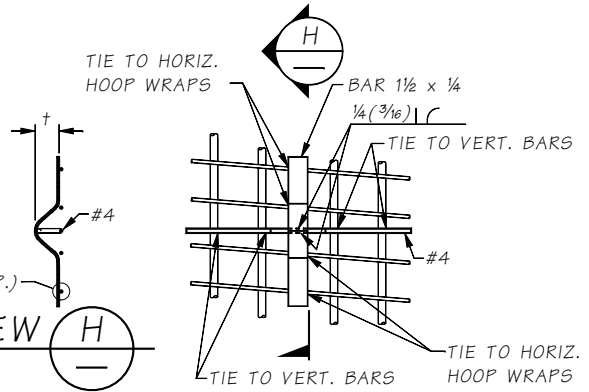

CENTRALIZER DETAIL

EPOXY COAT CENTRALIZER OR PAINT WITH INORGANIC ZINC AFTER FABRICATION (OPTION 2)

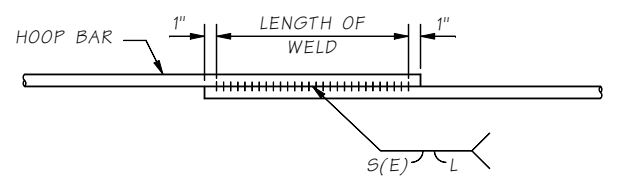

WELDED HOOP SPLICE DETAIL

WELDING SHALL MEET THE REQUIREMENTS OF STD. SPEC. 6-02.3(24)E

FOR WELD DIMENSIONS SEE TABLE BELOW.

RESISTANCE BUTT WELDED SPLICE MAY BE SUBSTITUTED AT THE CONTRACTOR'S OPTION. SEE SPECIAL PROVISIONS.

SHAFT HOOP INFORMATION			
DEFORMED BAR ASTM A 706	WELD DEMENSIONS		
	S	E	LENGTH (L)
#8 HOOP	1/2"	1/4"	8"

SHAFT BAR LIST

ALL REINFORCING SHALL BE ASTM A 706
QUANTITIES ARE PER SHAFT

MARK	SIZE	NO.	LENGTH	BEND TYPE	WT. (lbs.)
A	#18	30	112'-9"	STR.	46,002
B	#18	30	60'-0"	STR.	24,480
C	#8	227	28'-10"	66	17,481

TOTAL 87,963

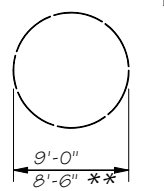

(a) ~ DETERMINED FROM PLANS
WEIGHT INCLUDES SPLICES

HOOP (BEND TYPE 66)

NOTES:

- EACH LEG SHOULD BE TIED TO TWO VERTICAL BARS OR TWO HOOPS.
- SEE SPECIAL PROVISIONS FOR SPACING REQUIREMENTS.
- + CONCRETE COVER MINUS 1/2"

SR 99 FILE NO. SHEET BG114

Bridge Design Engr. Khaleghi, B	M:\Y-Team\AW SOUTH INTERCHANGE\window files\Pier 3c Shaft Dtl's.WND	REGION NO.	STATE	FED. AID PROJ. NO.	SHEET NO.	TOTAL SHEETS
Supervisor Moore, TM		10	WASH.			
Designed By Talukdar, M	10/08					
Checked By Mizumori, A	08/09					
Detailed By Evans, A	10/08					
Bridge Projects Engr.						
Prelim. Plan By						
Architect/Specialist	DATE	REVISION	BY	APPD		



BRIDGE AND STRUCTURES OFFICE

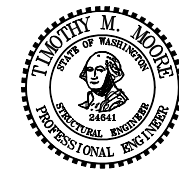

SR 99
ALASKAN WAY VIADUCT - REPLACEMENT
S HOLGATE ST TO S KING ST - PHASE 2
BRIDGE NO. 99/540 NB & SB

PIER 3C SHAFT DETAILS

BRIDGE SHEET NO. BG114
SHEET 960 OF 1475 SHEETS

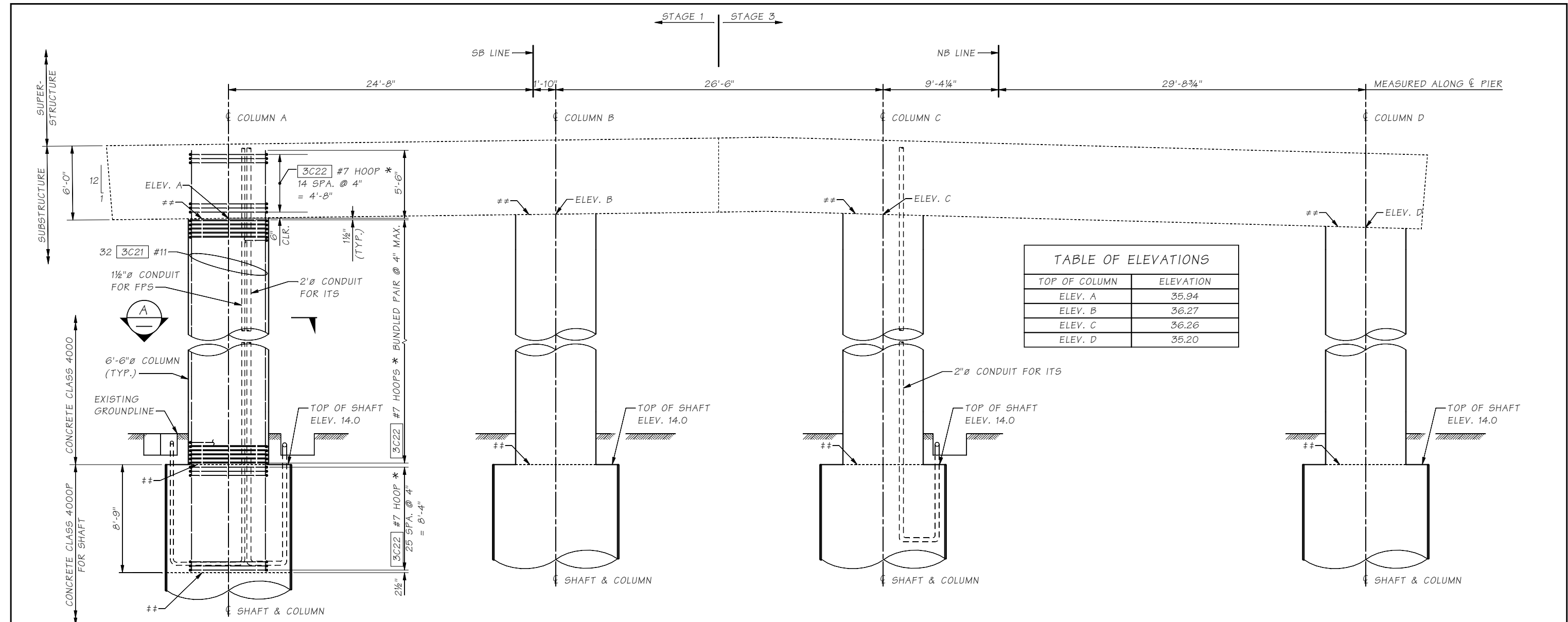

COLUMN ELEVATION - PIER 3C

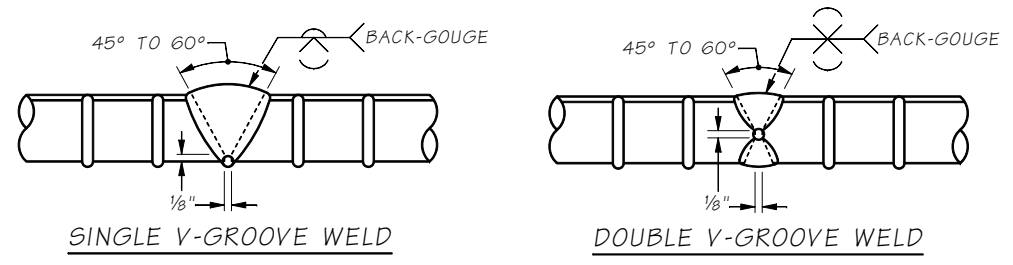

HOOP WELD DETAIL
ALL BACKING SHALL BE REMOVED

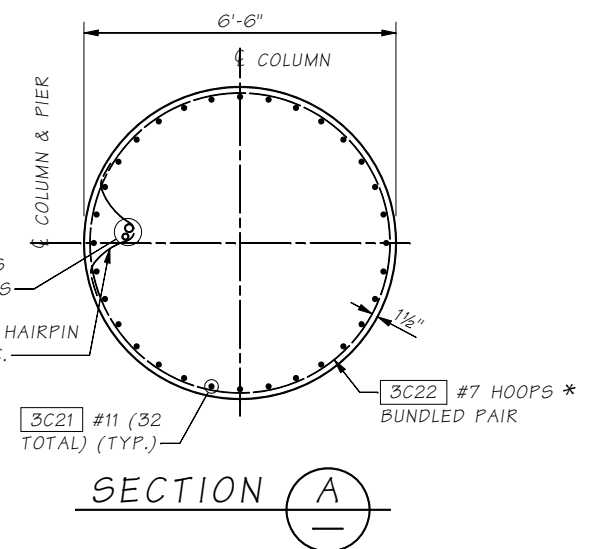

SECTION A

* HOOP WELD SHALL BE DIRECT BUTT-WELDED AND CONFORM TO THE CURRENT EDITION OF STRUCTURAL WELDING CODE - REINFORCING STEEL OF AWS(D1.4) AND MEET THE REQUIREMENTS OF STD. SPEC. 6-02.3(24)E RESISTANCE BUTT WELDED SPLICE MAY BE SUBSTITUTED AT THE CONTRACTOR'S OPTION. SEE SPECIAL PROVISIONS.

CONSTRUCTION JOINT w/ ROUGHENED SURFACE

NOTE:
COLUMN DETAILS & REINFORCING
TYPICAL FOR ALL COLUMNS.

SR 99 FILE NO. SHEET BGL15

Bridge Design Engr.	Khaleghi, B	M:\Y-Team\AWV SOUTH INTERCHANGE\window files\PIER 3C COLUMN.WND			
Supervisor	Moore, TM	REGION NO.	STATE	FED. AID PROJ. NO.	SHEET NO.
Designed By	Mizumori, A 10/08	10	WASH.		TOTAL SHEETS
Checked By	Talukdar, M 08/09	JOB NUMBER			
Detailed By	Andreotti, L 10/08	09A803			
Bridge Projects Engr.		DATE	REVISION	BY	APPD
Prelim. Plan By	2/17/10	REVISED SHEET	CSL	TMM	
Architect/Specialist					



BRIDGE AND STRUCTURES OFFICE

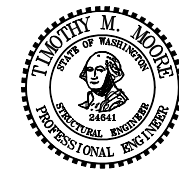

SR 99
ALASKAN WAY VIADUCT - REPLACEMENT
S HOLGATE ST TO S KING ST - PHASE 2
BRIDGE NO. 99/540 NB & SB
PIER 3C COLUMN DETAILS

BRIDGE SHEET NO. BGL15
SHEET 961 OF 1475 SHEETS

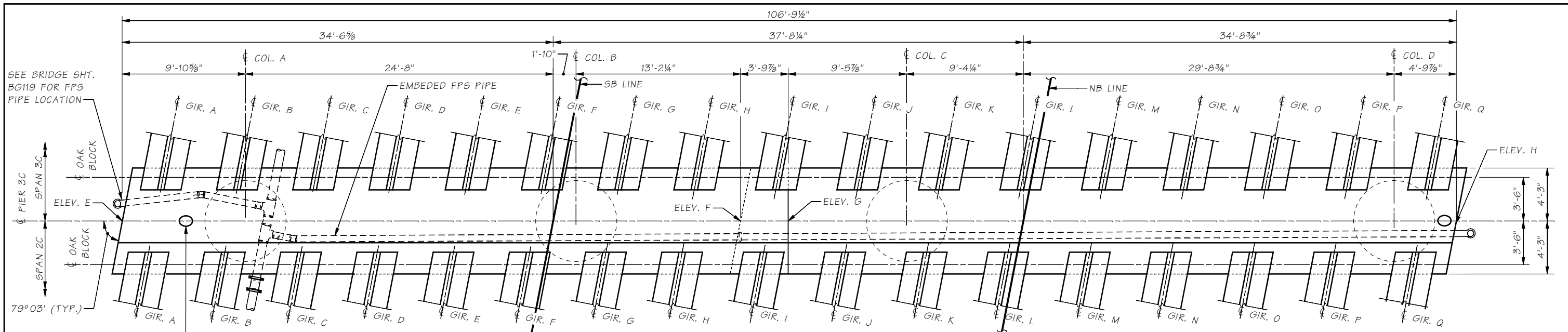

PLAN

SUBSTRUCTURE PORTION OF CROSSBEAM SHOWN

NOTE:
SEE FRAMING PLAN FOR GIRDER SPACING.

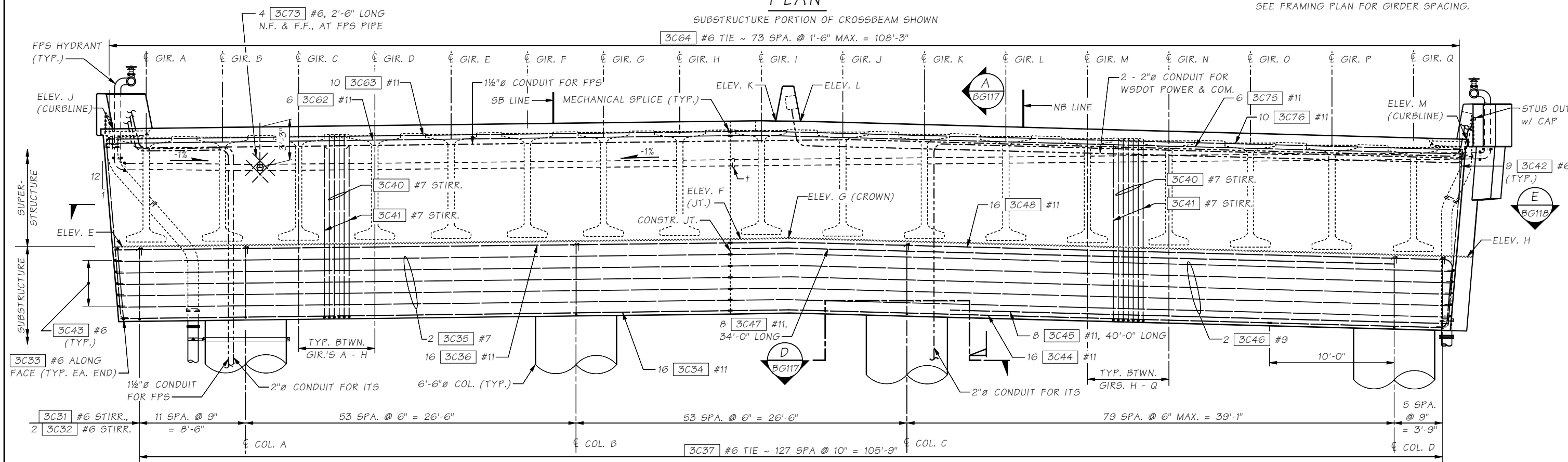

ELEVATION

SEE BR. SHEET BG119 FOR CROSSBEAM END DETAILS AND DETAILS BETWEEN GIRDERS.

N.F. = NEAR FACE
F.F. = FAR FACE

TABLE OF ELEVATIONS ~ (ALONG € PIER)							
LOCATION	ELEVATION	LOCATION	ELEVATION	LOCATION	ELEVATION	LOCATION	ELEVATION
E	41.82	G	42.51	J	51.30	L	51.96
F	42.44	H	41.07	K	51.95	M	50.55

SR 99 FILE NO. SHEET BGL16

Bridge Design Engr. Khaleghi, B	M:\Y-Team\AWV SOUTH INTERCHANGE\window files\Pier 3c X-Beam Plan-Elev.WND			REGION NO.	STATE	FED. AID PROJ. NO.	SHEET NO.	TOTAL SHEETS
Supervisor Moore, TM				10	WASH.			
Designed By Mizumori, A	05/09							
Checked By Talukdar, M	09/09							
Detailed By Evans, A	05/09							
Bridge Projects Engr.				JOB NUMBER				
Prelim. Plan By				09A803				
Architect/Specialist	DATE	REVISION	BY	APPD				



BRIDGE AND STRUCTURES OFFICE

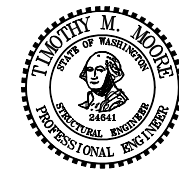

SR 99
ALASKAN WAY VIADUCT - REPLACEMENT
S HOLGATE ST TO S KING ST - PHASE 2
BRIDGE NO. 99/540 NB & SB

PIER 3C CROSSBEAM
PLAN AND ELEVATION

BRIDGE SHEET NO. **BG116**
SHEET 962 OF 1475 SHEETS

TABLE OF ELEVATIONS @ TOP OF OAK BLOCK

SPAN 2C GIRDERS (SB)	2A	2B	2C	2D	2E	2F	2G	2H	2I
	42.36	42.44	42.51	42.59	42.67	42.74	42.82	42.90	42.98
SPAN 2C GIRDERS (NB)	2J	2K	2L	2M	2N	2O	2P	2Q	
	42.89	42.71	42.54	42.36	42.18	42.01	41.83	41.66	
SPAN 3C GIRDERS (SB)	3A	3B	3C	3D	3E	3F	3G	3H	3I
	42.09	42.17	42.25	42.32	42.40	42.47	42.55	42.62	42.71
SPAN 3C GIRDERS (NB)	3J	3K	3L	3M	3N	3O	3P	3Q	
	42.61	42.44	42.26	42.09	41.91	41.73	41.55	41.38	

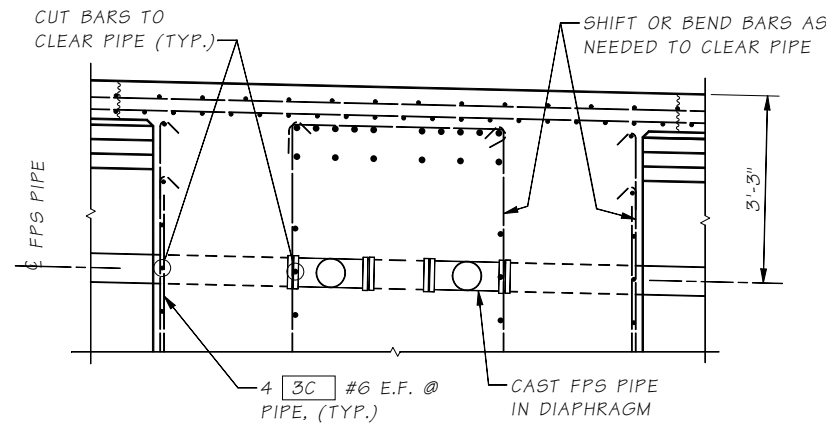

PIPE DETAIL

SECTION TAKEN BETWEEN GIRS. B AND C

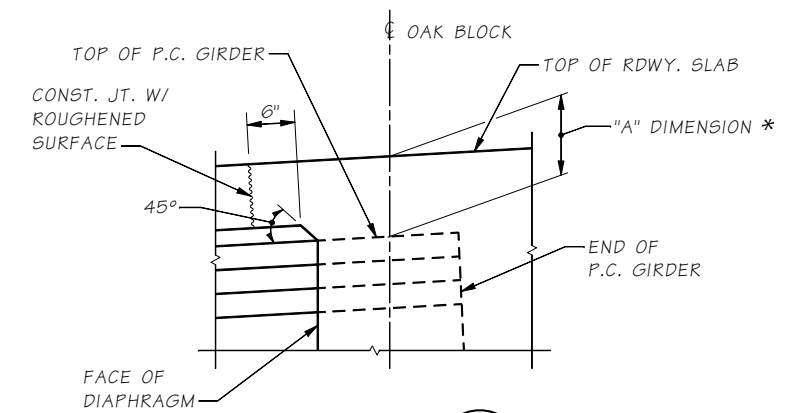

DETAIL C

REINFORCING NOT SHOWN FOR CLARITY

* SEE "GIRDER SCHEDULE" SHEETS.

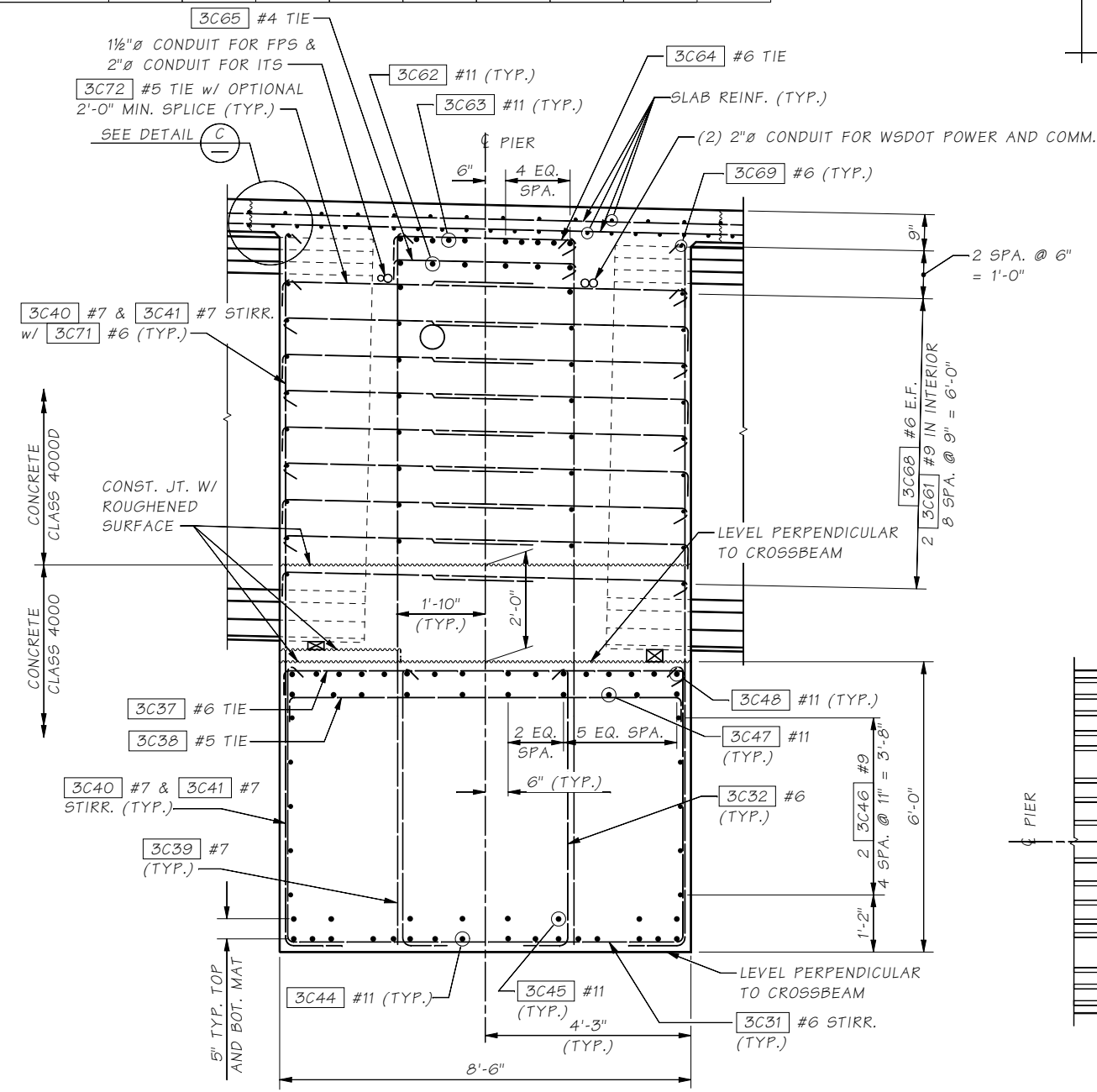

SECTION A

STAGE 2 SHOWN
STAGE 1 SIMILAR

BG116

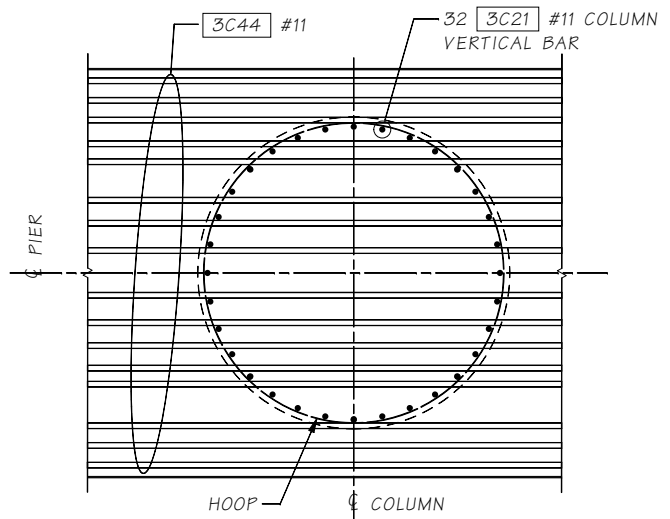

SECTION D

TRANSVERSE REINFORCING NOT SHOWN FOR CLARITY. ADJUST LONGITUDINAL BAR, TRANSVERSE STIRRUP, AND THE TIE SPACING AS REQUIRED TO CLEAR COLUMN VERTICAL BARS.

BG116

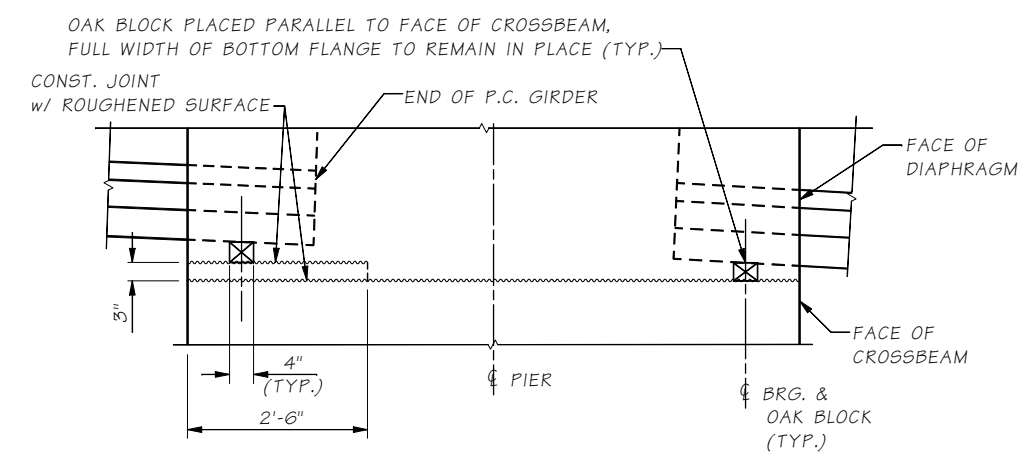

OAK BLOCK DETAIL

LONGITUDINAL DIMENSIONS ARE NORMAL TO PIER

SR 99 FILE NO. SHEET BG117

Bridge Design Engr.	Khaleghi, B	M:\Y-Team\AWV SOUTH INTERCHANGE\window files\PIER 3C CROSSBEAM I.WND			
Supervisor	Moore, TM	REGION NO.	STATE	FED. AID PROJ. NO.	SHEET NO.
Designed By	Mizumori, A 10/08	10	WASH.		TOTAL SHEETS
Checked By	Talukdar, M 09/09	JOB NUMBER 09A803			
Detailed By	Andreotti, L 04/09				
Bridge Projects Engr.					
Prelim. Plan By					
Architect/Specialist		DATE	REVISION	BY	APPD



BRIDGE AND STRUCTURES OFFICE

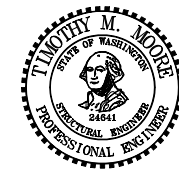

SR 99
ALASKAN WAY VIADUCT - REPLACEMENT
S HOLGATE ST TO S KING ST - PHASE 2
BRIDGE NO. 99/540 NB & SB
PIER 3C CROSSBEAM DETAILS 1 OF 3

BRIDGE SHEET NO. BG117
SHEET 963 OF 1475 SHEETS

SR 99 FILE NO. SHEET BGL18

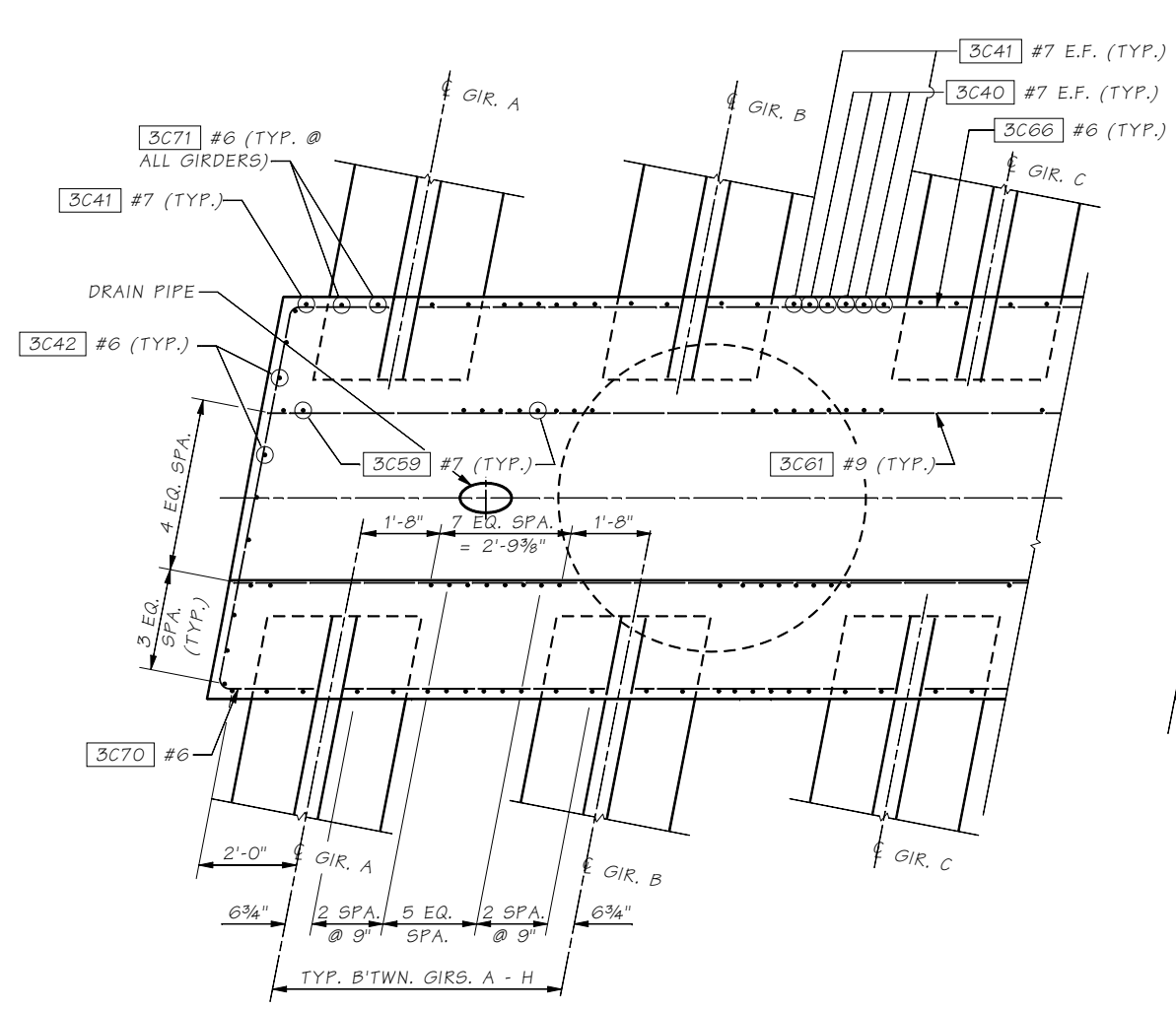

SECTION E
BG116

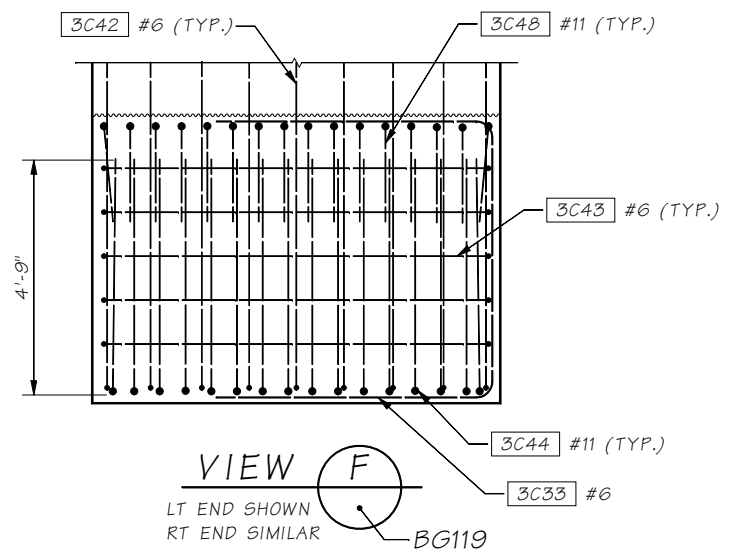
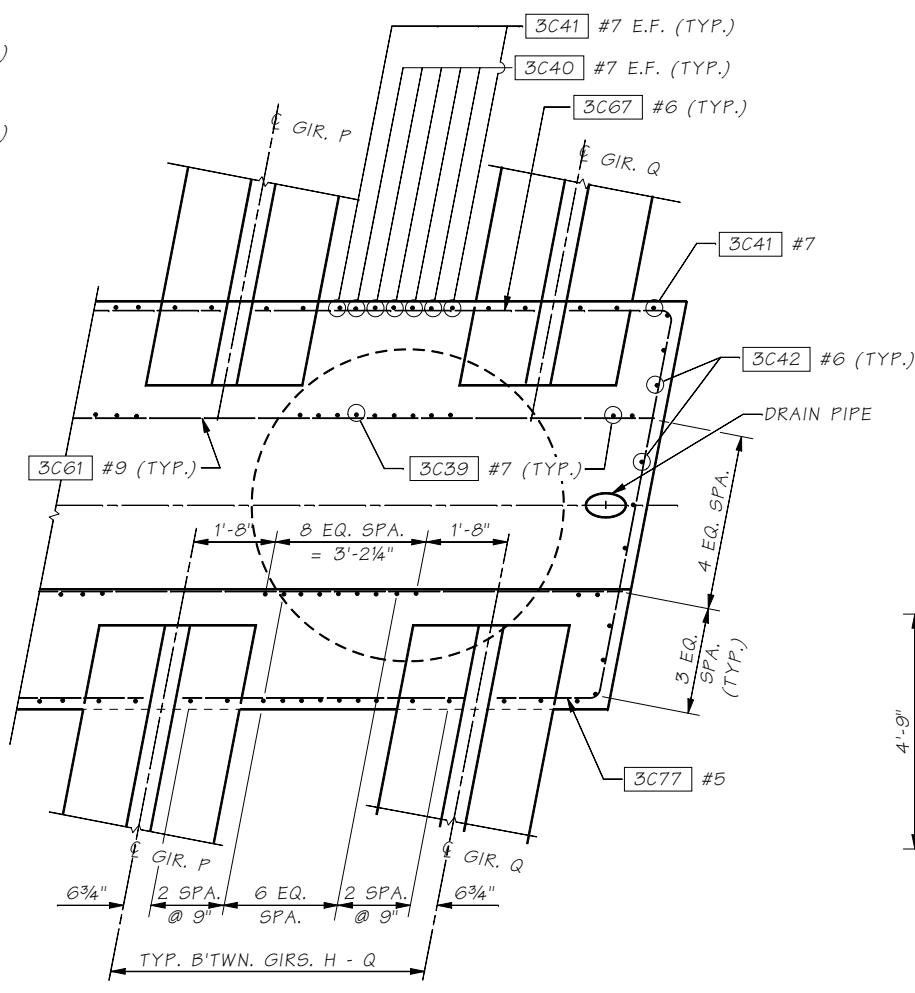

Bridge Design Engr.	Khaleghi, B	M:\Y-Team\AWV SOUTH INTERCHANGE\window files\PIER 3C CROSSBEAM 2.WND			
Supervisor	Moore, TM	REGION NO.	STATE	FED. AID PROJ. NO.	SHEET NO.
Designed By	Mizumori, A 10/08	10	WASH.		TOTAL SHEETS
Checked By	Talukdar, M 09/09	JOB NUMBER 09A803			
Detailed By	Evans, A 10/08				
Bridge Projects Engr.					
Prelim. Plan By					
Architect/Specialist		DATE	REVISION	BY	APPD



BRIDGE AND STRUCTURES OFFICE

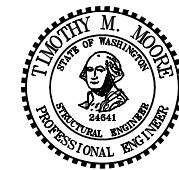

SR 99
ALASKAN WAY VIADUCT - REPLACEMENT
S HOLGATE ST TO S KING ST - PHASE 2
BRIDGE NO. 99/540 NB & SB
PIER 3C CROSSBEAM DETAILS 2 OF 3

BRIDGE SHEET NO. BG118
SHEET 964 OF 1475 SHEETS

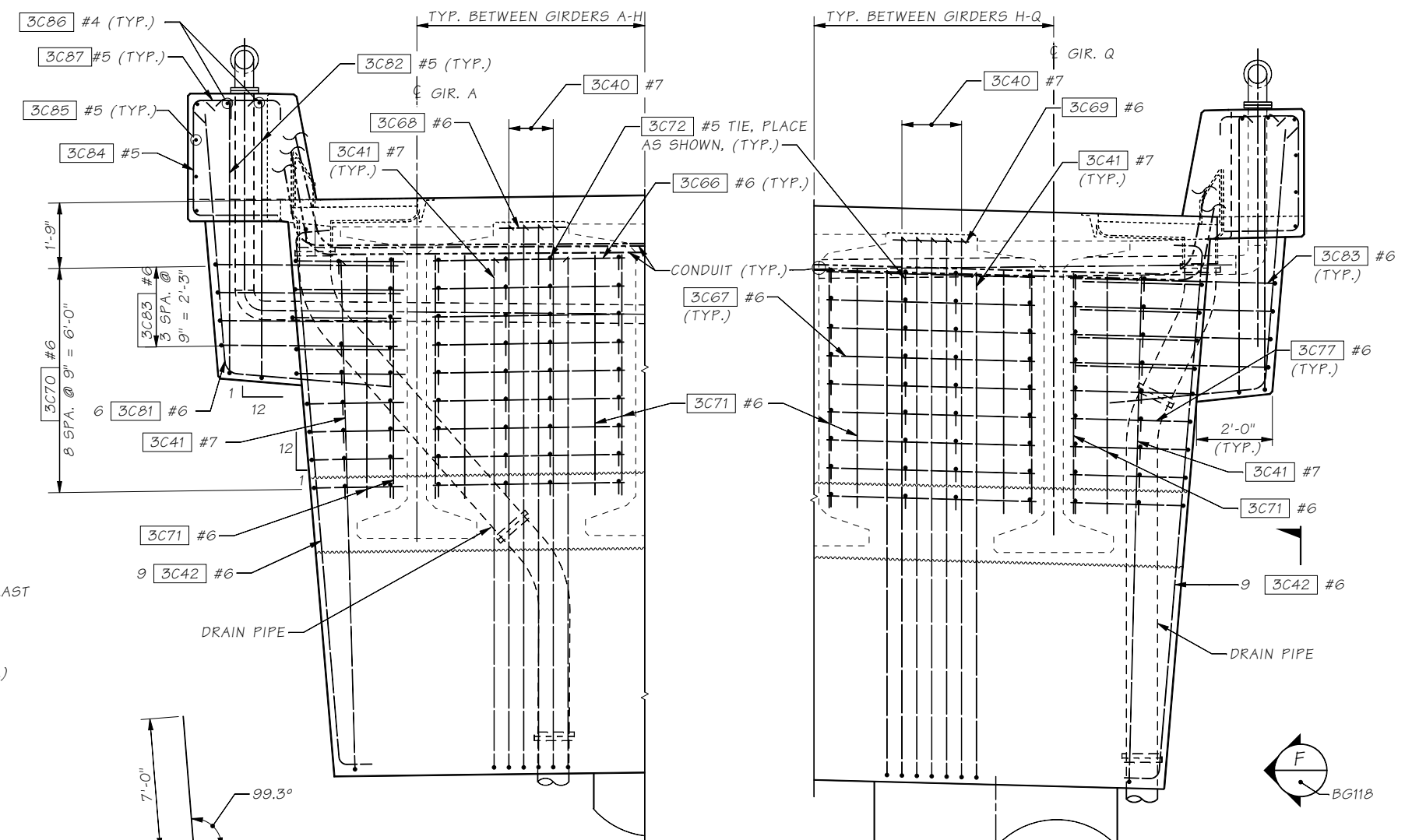
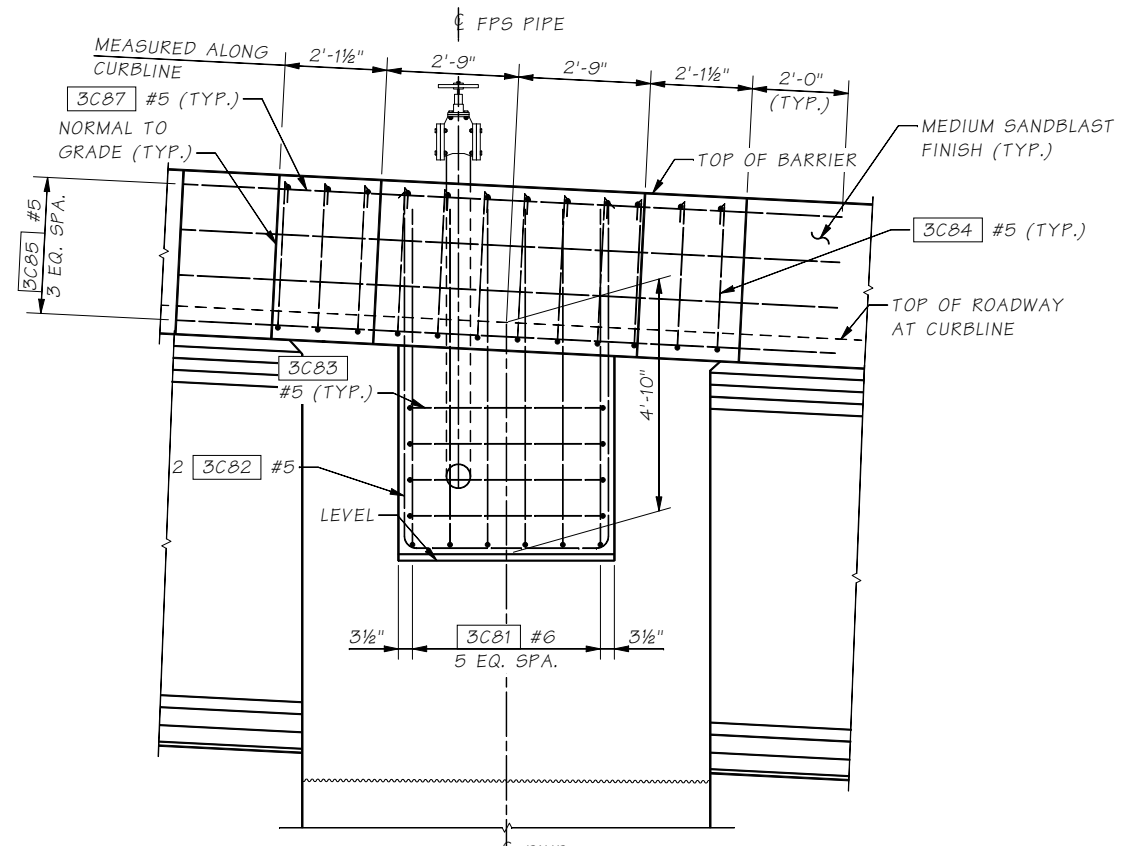
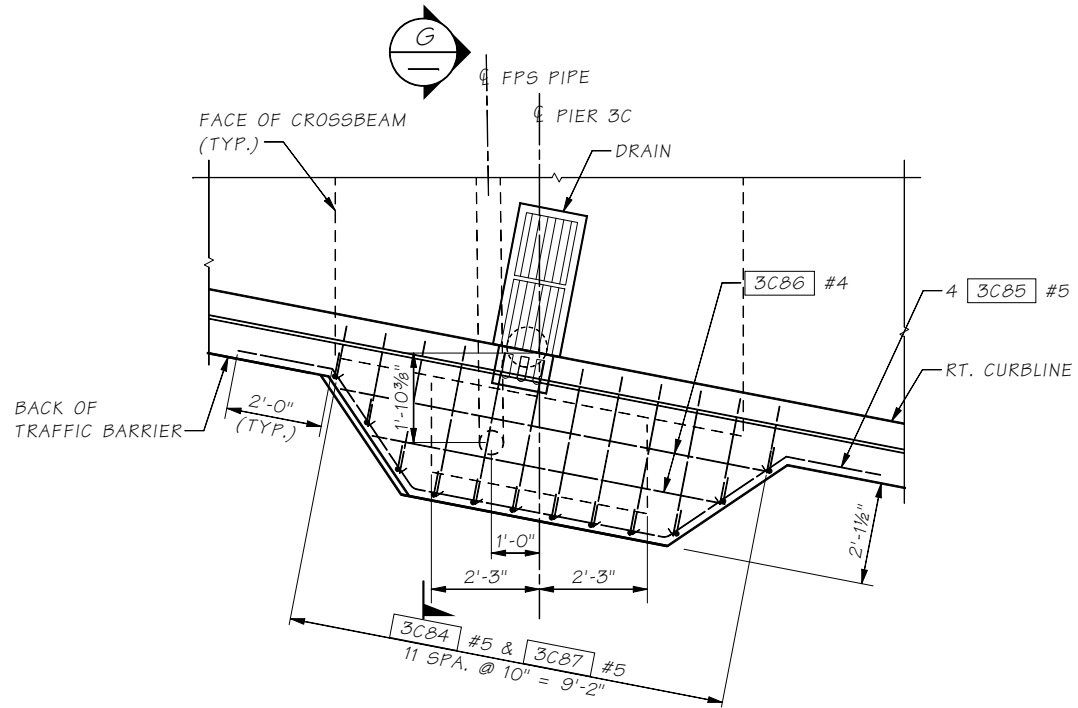

SR 99 FILE NO. SHEET BGL19

Bridge Design Engr.	Khaleghi, B	M:\Y-Team\AWV SOUTH INTERCHANGE\window files\PIER 3C CROSSBEAM 3.WND				REGION NO.	STATE	FED. AID PROJ. NO.	SHEET NO.	TOTAL SHEETS
Supervisor	Moore, TM				10	WASH.				
Designed By	Mizumori, A	05/09								
Checked By	Talukdar, M	09/09								
Detailed By	Andreotti, L	05/09								
Bridge Projects Engr.										
Prelim. Plan By										
Architect/Specialist										
	DATE	REVISION	BY	APPD						



BRIDGE AND STRUCTURES OFFICE

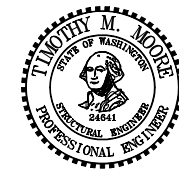

SR 99
ALASKAN WAY VIADUCT - REPLACEMENT
S HOLGATE ST TO S KING ST - PHASE 2
BRIDGE NO. 99/540 NB & SB
PIER 3C CROSSBEAM DETAILS 3 OF 3

BRIDGE SHEET NO. BGL19
SHEET 965 OF 1475 SHEETS

SR 99 FILE NO. SHEET BG120

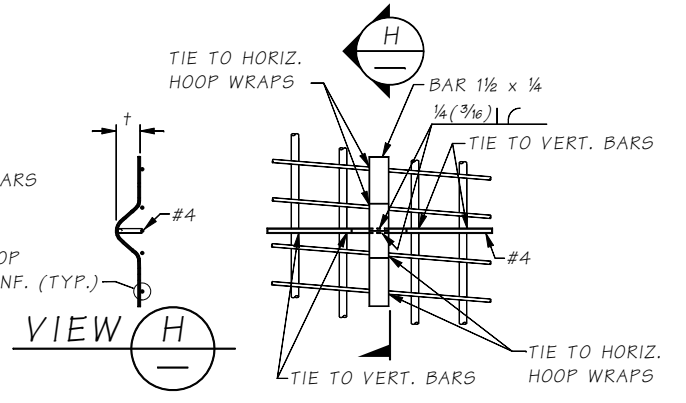
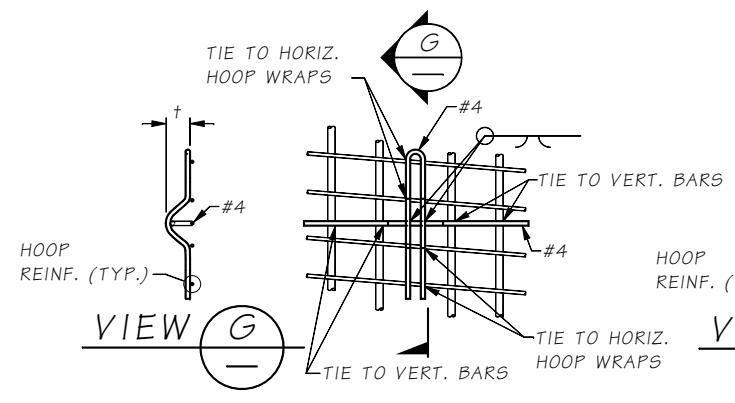
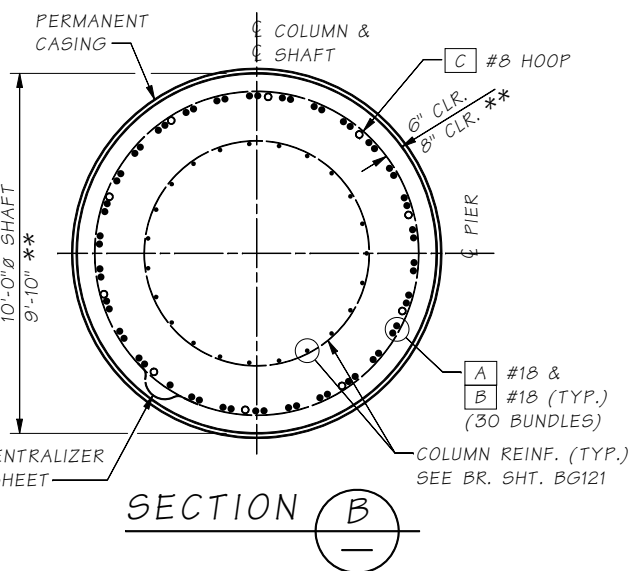
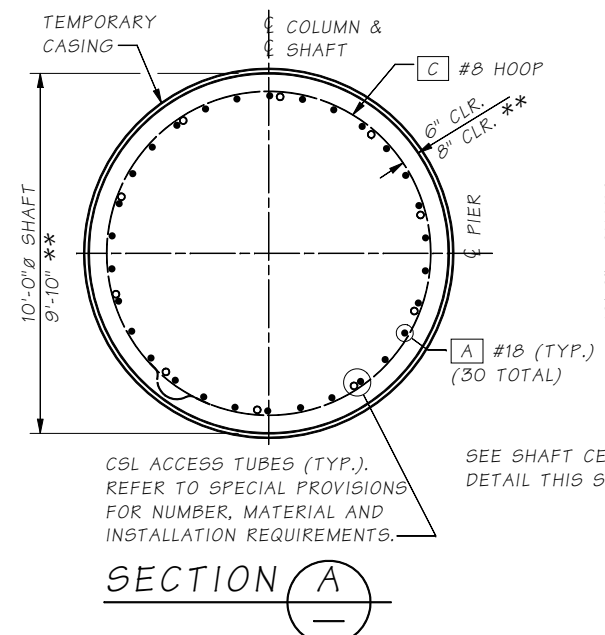
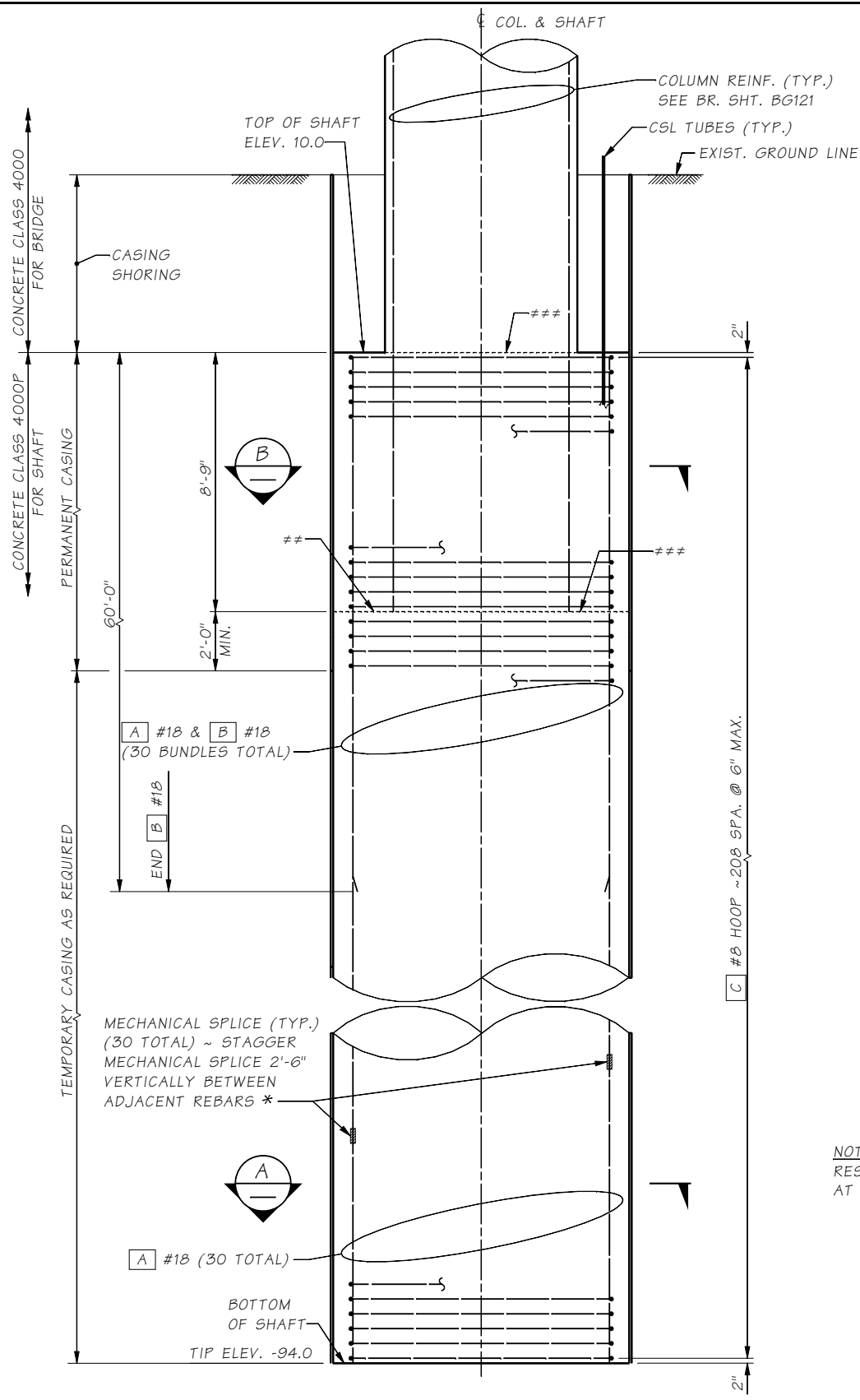

- * MECHANICAL SPLICE SHALL MEET THE REQUIREMENTS OF STD. SPEC. 6-02.3(24)F
- ** SHAFT CONSTRUCTED WITH THE OSCILLATOR METHOD. THE CONTRACTOR SHALL REVISE THE SHAFT BARLIST IF THE OSCILLATOR METHOD IS CHOSEN FOR SHAFT CONSTRUCTION
- ** REMOVE SEDIMENT LAITENCE & WEAK CONCRETE TO SOUND CONCRETE PRIOR TO SETTING COLUMN REINFORCEMENT
- *** CONST. JOINT WITH ROUGHENED SURFACE

NOTE:
RESISTANCE BUTT WELDED SPLICE MAY BE SUBSTITUTED AT THE CONTRACTOR'S OPTION. SEE SPECIAL PROVISIONS.

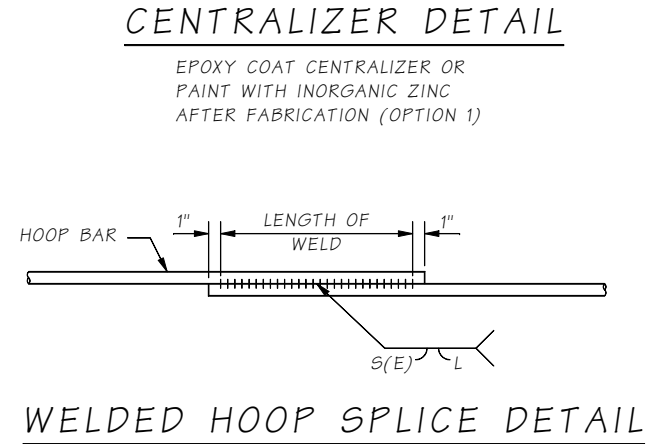

WELDING SHALL MEET THE REQUIREMENTS OF STD. SPEC. 6-02.3(24)E
FOR WELD DIMENSIONS SEE TABLE BELOW.
RESISTANCE BUTT WELDED SPLICE MAY BE SUBSTITUTED AT THE CONTRACTOR'S OPTION. SEE SPECIAL PROVISIONS.

SHAFT HOOP INFORMANTION			
DEFORMED BAR ASTM A 706	WELD DEMENSIONS		
	S	E	LENGTH (L)
#8 HOOP	1/2"	1/4"	8"

SHAFT BAR LIST

ALL REINFORCING SHALL BE ASTM A 706
QUANTITIES ARE PER SHAFT

MARK	SIZE	NO.	LENGTH	BEND TYPE	WT. (lbs.)
A	#18	30	103'-9"	STR.	42,330
B	#18	30	60'-0"	STR.	24,480
C	#8	209	28'-10"	66	16,095

TOTAL 82,905

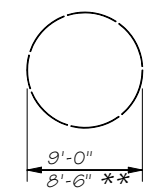

(a) ~ DETERMINED FROM PLANS
WEIGHT INCLUDES SPLICES
HOOP (BEND TYPE 66)

CENTRALIZER DETAIL

EPOXY COAT CENTRALIZER OR PAINT WITH INORGANIC ZINC AFTER FABRICATION (OPTION 2)

NOTES:

1. EACH LEG SHOULD BE TIED TO TWO VERTICAL BARS OR TWO HOOPS.
2. SEE SPECIAL PROVISIONS FOR SPACING REQUIREMENTS.
3. + CONCRETE COVER MINUS 1/2"

Bridge Design Engr. Khaleghi, B	M:\Y-Team\AWV SOUTH INTERCHANGE\window files\Pier 4C Shaft Dtl's.WND	REGION NO.	STATE	FED. AID PROJ. NO.	SHEET NO.	TOTAL SHEETS
Supervisor Moore, TM		10	WASH.			
Designed By Talukdar, M	10/08					
Checked By Mizumori, A	08/09					
Detailed By Evans, A	10/08					
Bridge Projects Engr.						
Prelim. Plan By						
Architect/Specialist	DATE	REVISION	BY	APPD		



BRIDGE AND STRUCTURES OFFICE

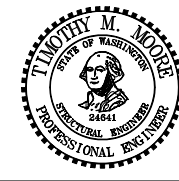

SR 99
ALASKAN WAY VIADUCT - REPLACEMENT
S HOLGATE ST TO S KING ST - PHASE 2
BRIDGE NO. 99/540 NB & SB

PIER 4C SHAFT DETAILS

BRIDGE SHEET NO. BG120
SHEET 966 OF 1475 SHEETS

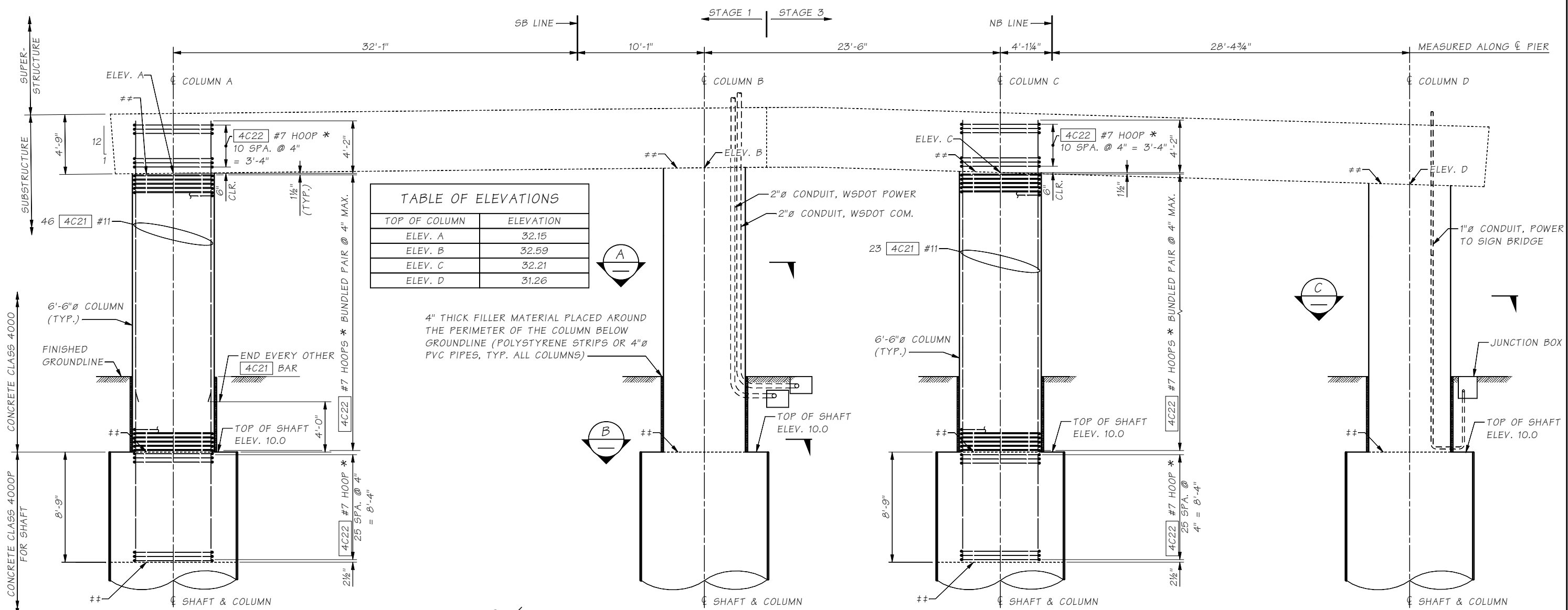

TOP OF COLUMN	ELEVATION
ELEV. A	32.15
ELEV. B	32.59
ELEV. C	32.21
ELEV. D	31.26

4" THICK FILLER MATERIAL PLACED AROUND THE PERIMETER OF THE COLUMN BELOW GROUNDLINE (POLYSTYRENE STRIPS OR 4"Ø PVC PIPES, TYP. ALL COLUMNS)

COLUMN ELEVATION - PIER 4C

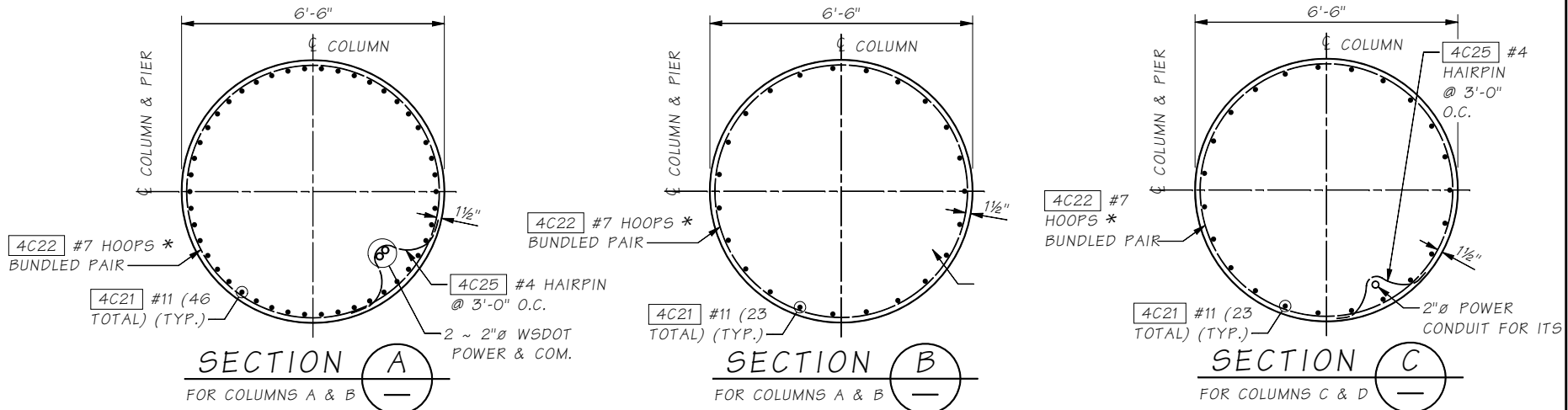
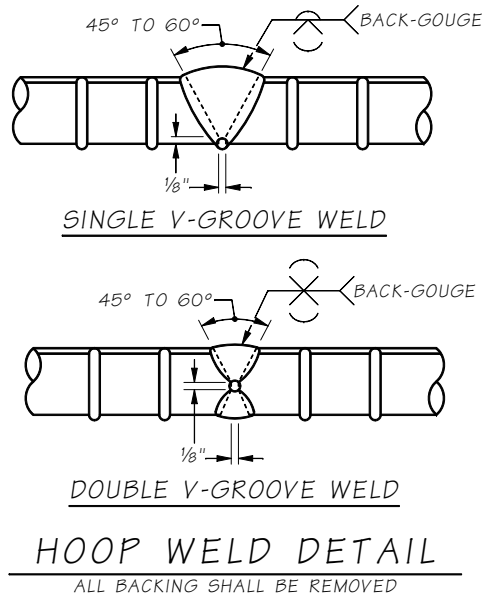

NOTE:
COLUMN DETAILS & REINFORCING ARE THE SAME FOR COLUMNS A & B. COLUMN DETAILS & REINFORCING ARE THE SAME FOR COLUMNS C & D.

CONSTRUCTION JOINT w/ ROUGHENED SURFACE

* HOOP WELD SHALL BE DIRECT BUTT-WELDED AND CONFORM TO THE CURRENT EDITION OF STRUCTURAL WELDING CODE - REINFORCING STEEL OF AWS(D1.4) AND MEET THE REQUIREMENTS OF STD. SPEC. 6-02.3(24)E RESISTANCE BUTT WELDED SPLICE MAY BE SUBSTITUTED AT THE CONTRACTOR'S OPTION. SEE SPECIAL PROVISIONS.

SR 99 FILE NO. SHEET BG121

Bridge Design Engr.	Khaleghi, B	M:\Y-Team\AWV SOUTH INTERCHANGE\window files\Pier 4C col Dtl 1.WND			
Supervisor	Moore, TM	REGION NO.	STATE	FED. AID PROJ. NO.	SHEET TOTAL SHEETS
Designed By	Mizumori, A 10/08	10	WASH.		
Checked By	Talukdar, M 08/09	JOB NUMBER			
Detailed By	Evans, A 10/08	09A803			
Bridge Projects Engr.		DATE	REVISION	BY	APPD
Prelim. Plan By					
Architect/Specialist					



BRIDGE AND STRUCTURES OFFICE

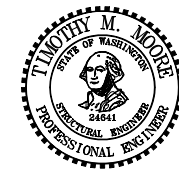

SR 99
ALASKAN WAY VIADUCT - REPLACEMENT
S HOLGATE ST TO S KING ST - PHASE 2
BRIDGE NO. 99/540 NB & SB
PIER 4C COLUMN DETAILS

BRIDGE SHEET NO. BG121
SHEET 967 OF 1475 SHEETS

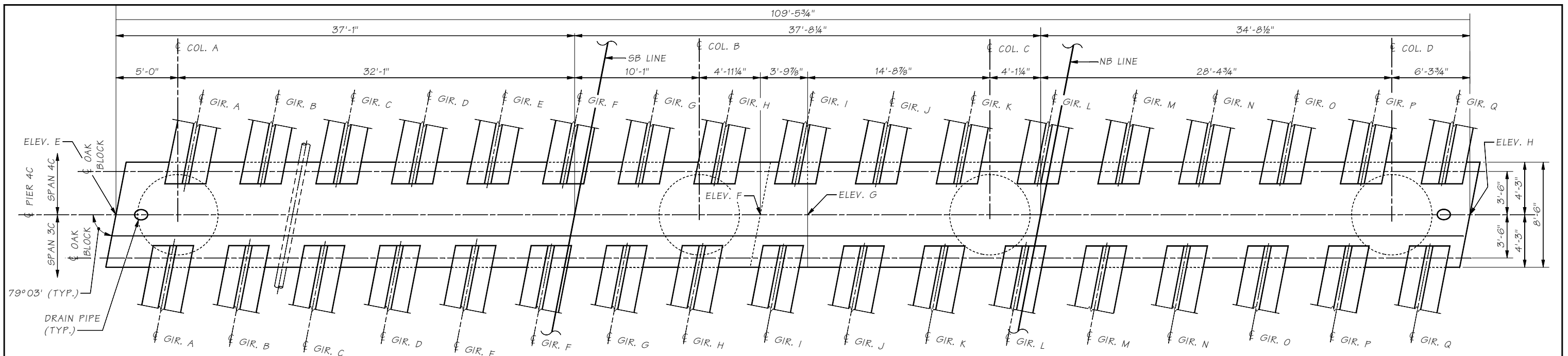

PLAN

SUBSTRUCTURE PORTION OF CROSSBEAM SHOWN.

NOTE:
SEE FRAMING PLAN FOR GIRDER SPACING.

4 4C73 #6, 2'-6" LONG
N.F. & F.F., AT FPS PIPE
1'-0" Ø BLOCKOUT AROUND
PIPE

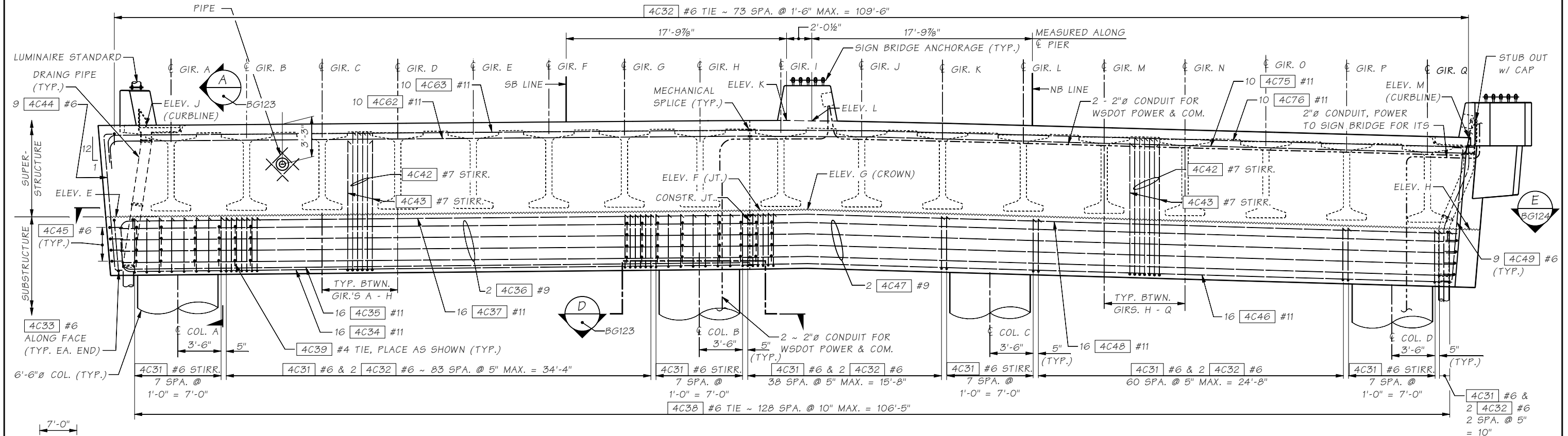

ELEVATION

SEE BR. SHEET BG125 FOR CROSSBEAM END DETAILS
AND DETAILS BETWEEN GIRDERS.

TABLE OF ELEVATIONS ~ (ALONG € PIER)

LOCATION	ELEVATION	LOCATION	ELEVATION	LOCATION	ELEVATION	LOCATION	ELEVATION
E	36.85	G	37.39	J	44.40	L	44.89
F	37.38	H	35.83	K	44.94	M	43.36

N.F. = NEAR FACE
F.F. = FAR FACE

SR 99 FILE NO. SHEET BG122

Bridge Design Engr. Khaleghi, B	M:\Y-Team\AWV SOUTH INTERCHANGE\window files\Pier 4C X-Beam Plan-Elev.WND			REGION NO.	STATE	FED. AID PROJ. NO.	SHEET NO.	TOTAL SHEETS
Supervisor Moore, TM				10	WASH.			
Designed By Mizumori, A	05/09							
Checked By Talukdar, M	09/09							
Detailed By Andreotti, L	05/09							
Bridge Projects Engr.				JOB NUMBER				
Prelim. Plan By				09A803				
Architect/Specialist	DATE	REVISION	BY	APPD				



BRIDGE AND STRUCTURES OFFICE

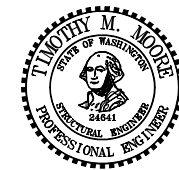

SR 99
ALASKAN WAY VIADUCT - REPLACEMENT
S HOLGATE ST TO S KING ST - PHASE 2
BRIDGE NO. 99/540 NB & SB

PIER 4C CROSSBEAM
PLAN AND ELEVATION

BRIDGE SHEET NO. BG122
SHEET 968 OF 1475 SHEETS

TABLE OF ELEVATIONS @ TOP OF OAK BLOCK

SPAN 3C GIRDERS (SB)	3A	3B	3C	3D	3E	3F	3G	3H	3I
	37.67	37.73	37.80	37.86	37.92	37.99	38.05	38.11	38.18
SPAN 3C GIRDERS (NB)	3J	3K	3L	3M	3N	3O	3P	3Q	
	38.01	37.82	37.63	37.44	37.25	37.06	36.87	36.68	
SPAN 4C GIRDERS (SB)	4A	4B	4C	4D	4E	4F	4G	4H	4I
	37.13	37.20	37.26	37.32	37.38	37.45	37.51	37.57	37.64
SPAN 4C GIRDERS (NB)	4J	4K	4L	4M	4N	4O	4P	4Q	
	37.47	37.28	37.09	36.90	36.71	36.52	36.33	36.14	

** 4C39 #4, 4C41A #7, 4C42A #7 & 4C43A #7
ARE ONLY REQUIRED NEAR COLUMNS A & B. SEE
BRIDGE SHEET BG124 FOR DETAILS.

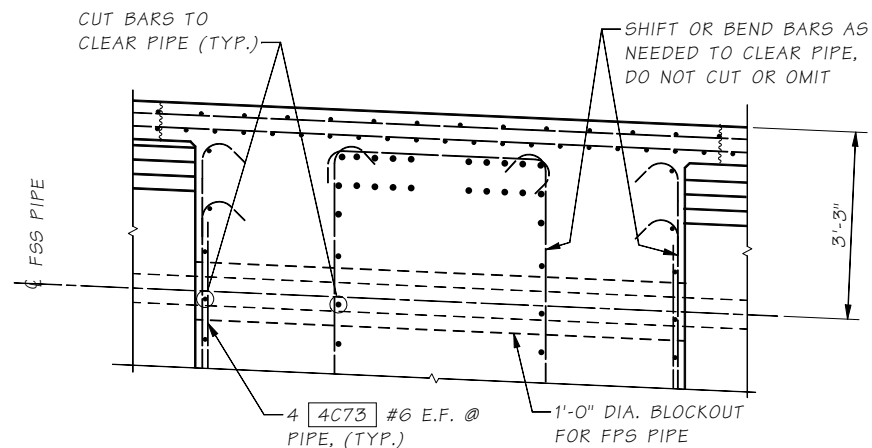

PIPE DETAIL

SECTION TAKEN BETWEEN GIRS. B AND C

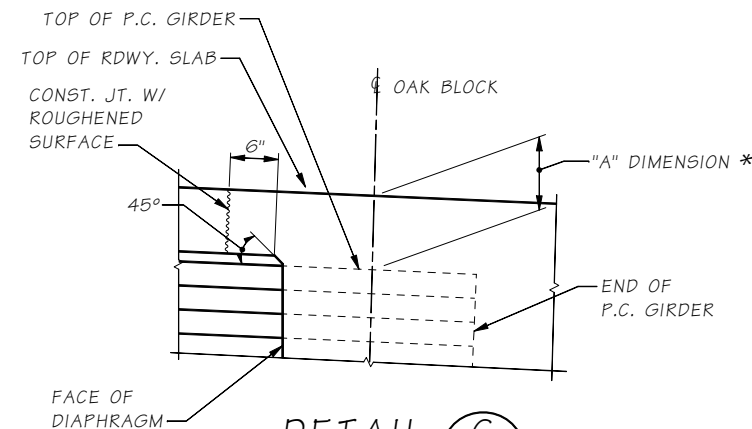

DETAIL C

REINFORCING NOT SHOWN FOR CLARITY

* SEE "GIRDER SCHEDULE" SHEETS.

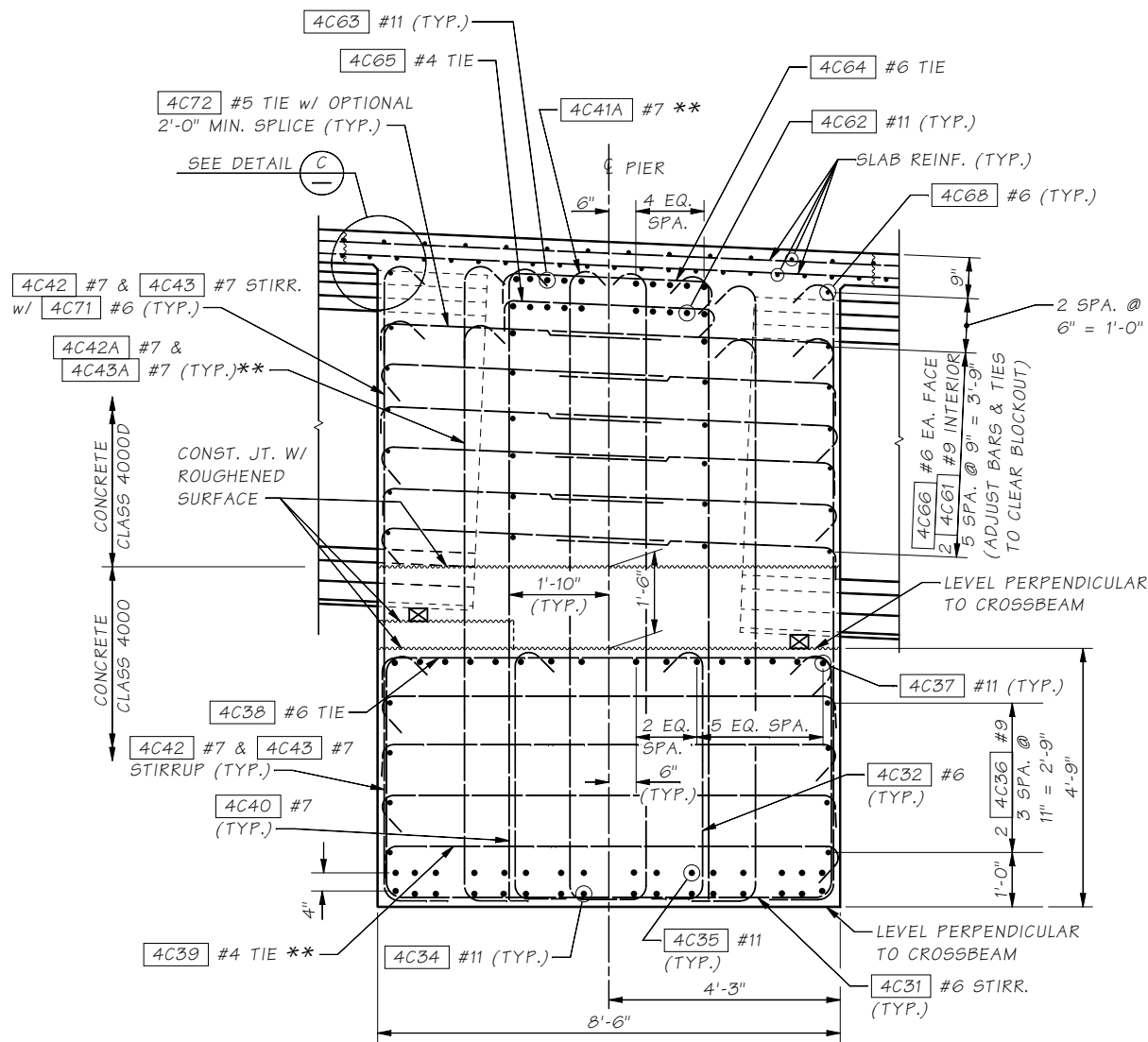

SECTION A

STAGE 1 SHOWN
STAGE 2 SIMILAR

BG122

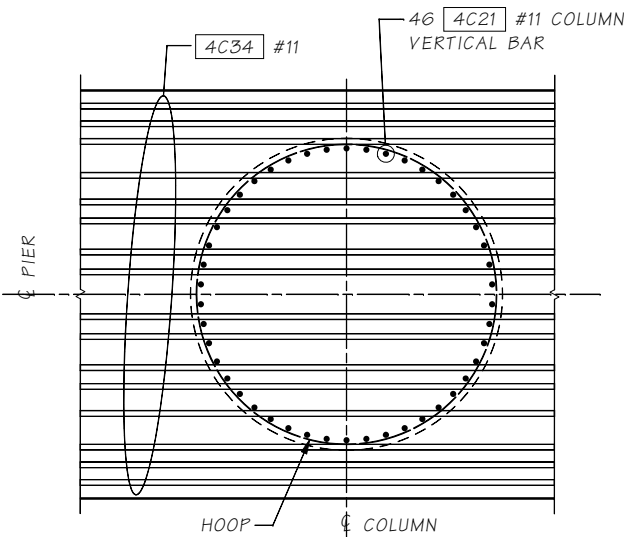

SECTION D

TRANSVERSE REINFORCING NOT SHOWN FOR CLARITY. ADJUST LONGITUDINAL BAR, TRANSVERSE STIRRUP, AND THE TIE SPACING AS REQUIRED TO CLEAR COLUMN VERTICAL BARS. (SHOWN FOR COLUMN 4B, SAME FOR 4A, SIMILAR FOR COLUMNS 4C & 4D)

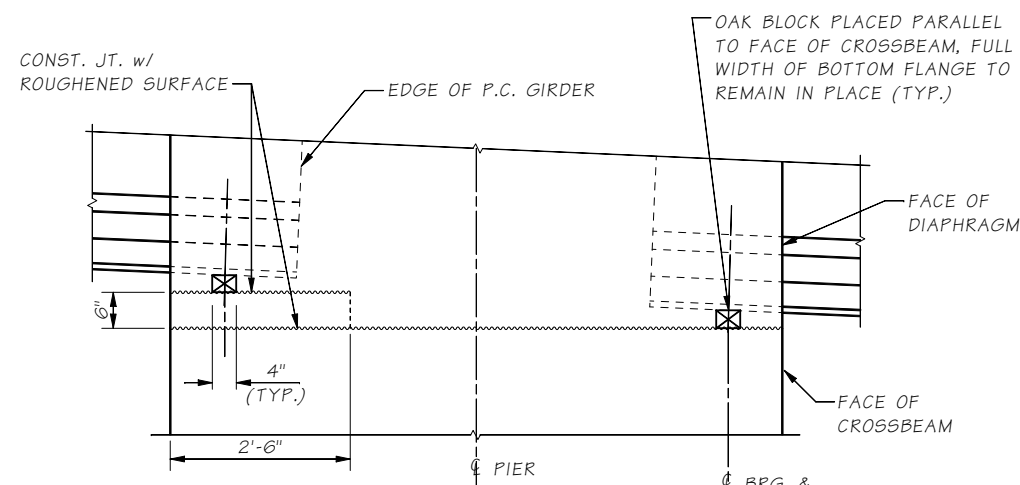

OAK BLOCK DETAIL

LONGITUDINAL DIMENSIONS ARE NORMAL TO PIER

SR 99 FILE NO. SHEET BG123

Bridge Design Engr.	Khaleghi, B	M:\Y-Team\AWV SOUTH INTERCHANGE\window files\PIER 4C CROSSBEAM I.WND			
Supervisor	Moore, TM	REGION NO.	STATE	FED. AID PROJ. NO.	SHEET NO.
Designed By	Mizumori, A	10	WASH.		TOTAL SHEETS
Checked By	Talukdar, M	JOB NUMBER 09A803			
Detailed By	Andreotti, L				
Bridge Projects Engr.					
Prelim. Plan By					
Architect/Specialist		DATE	REVISION	BY	APPD

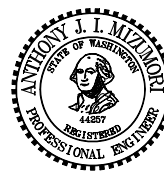

BRIDGE AND STRUCTURES OFFICE

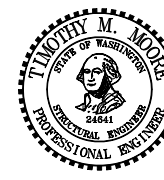

SR 99
ALASKAN WAY VIADUCT - REPLACEMENT
S HOLGATE ST TO S KING ST - PHASE 2
BRIDGE NO. 99/540 NB & SB

PIER 4C CROSSBEAM DETAILS 1 OF 3

BRIDGE SHEET NO. BG123
SHEET 969 OF 1475 SHEETS

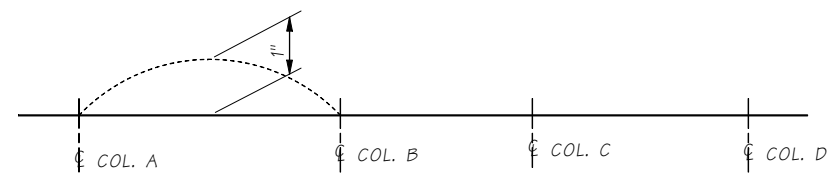
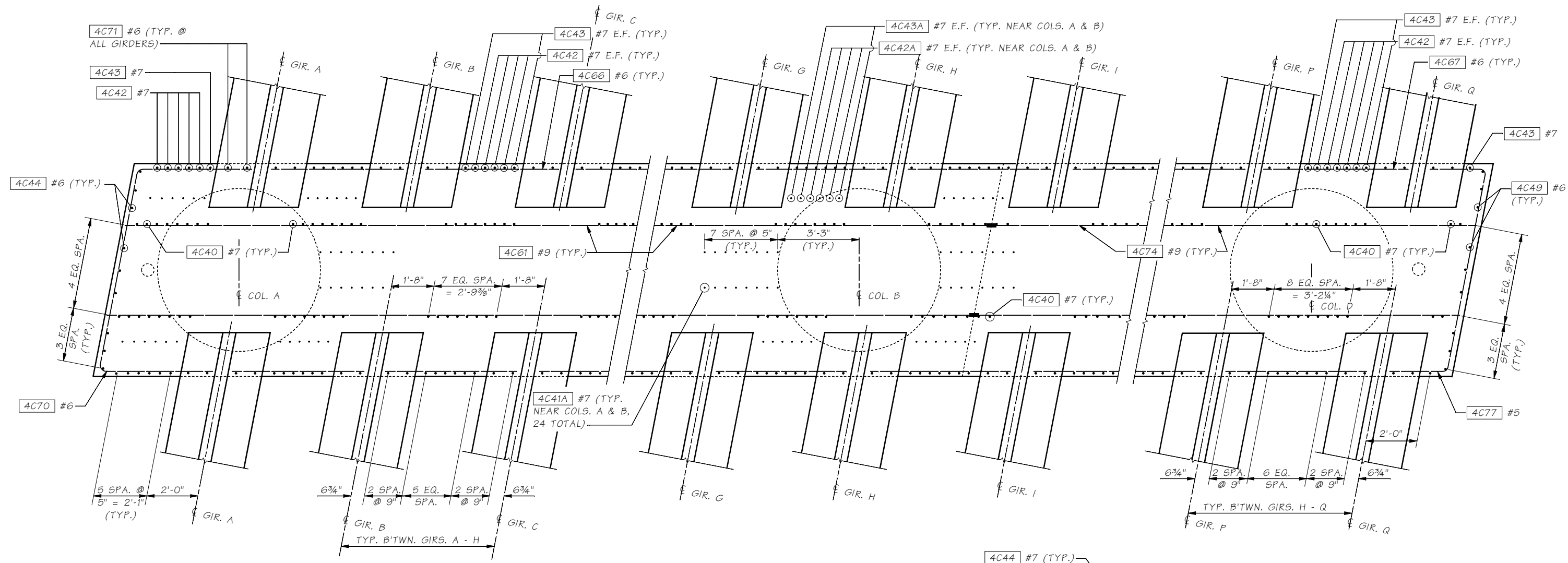

LOWER CROSSBEAM CAMBER DIAGRAM

THE LOWER PORTION OF THE STAGE 1 CROSSBEAM SHALL BE CAMBERED TO COMPENSATE FOR DEAD LOAD DEFLECTION ASSOCIATED WITH GIRDER, DIAPHRAGM, AND DECK WEIGHT.

SECTION E
BG122

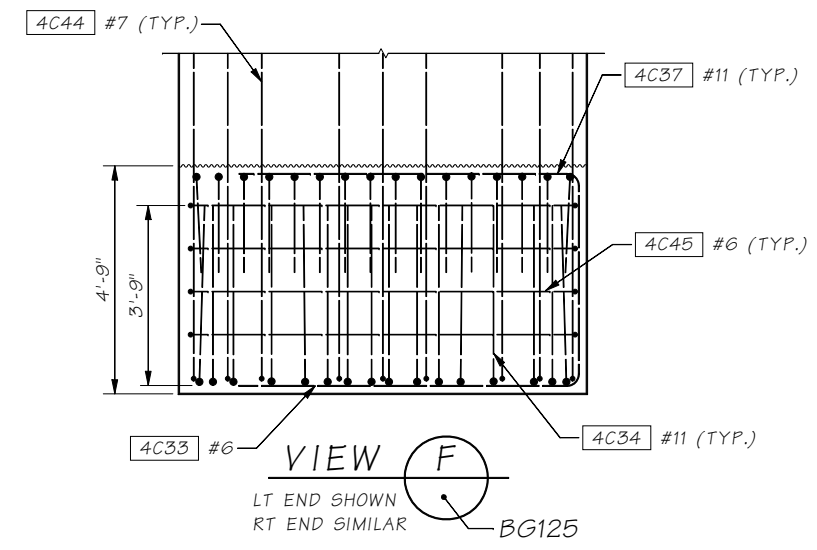

Bridge Design Engr. Khaleghi, B	M:\Y-Team\AWV SOUTH INTERCHANGE\window files\PIER 4C CROSSBEAM 2.WND	REGION NO.	STATE	FED. AID PROJ. NO.	SHEET NO.	TOTAL SHEETS
Supervisor Moore, TM		10	WASH.			
Designed By Mizumori, A	10/08	JOB NUMBER 09A803				
Checked By Talukdar, M	09/09					
Detailed By Evans, A	10/08					
Bridge Projects Engr.						
Prelim. Plan By						
Architect/Specialist	DATE	REVISION	BY	APPD		

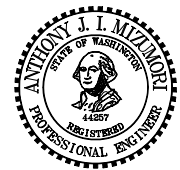

BRIDGE AND STRUCTURES OFFICE

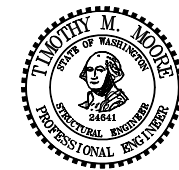

SR 99
ALASKAN WAY VIADUCT - REPLACEMENT
S HOLGATE ST TO S KING ST - PHASE 2
BRIDGE NO. 99/540 NB & SB
PIER 4C CROSSBEAM DETAILS 2 OF 3

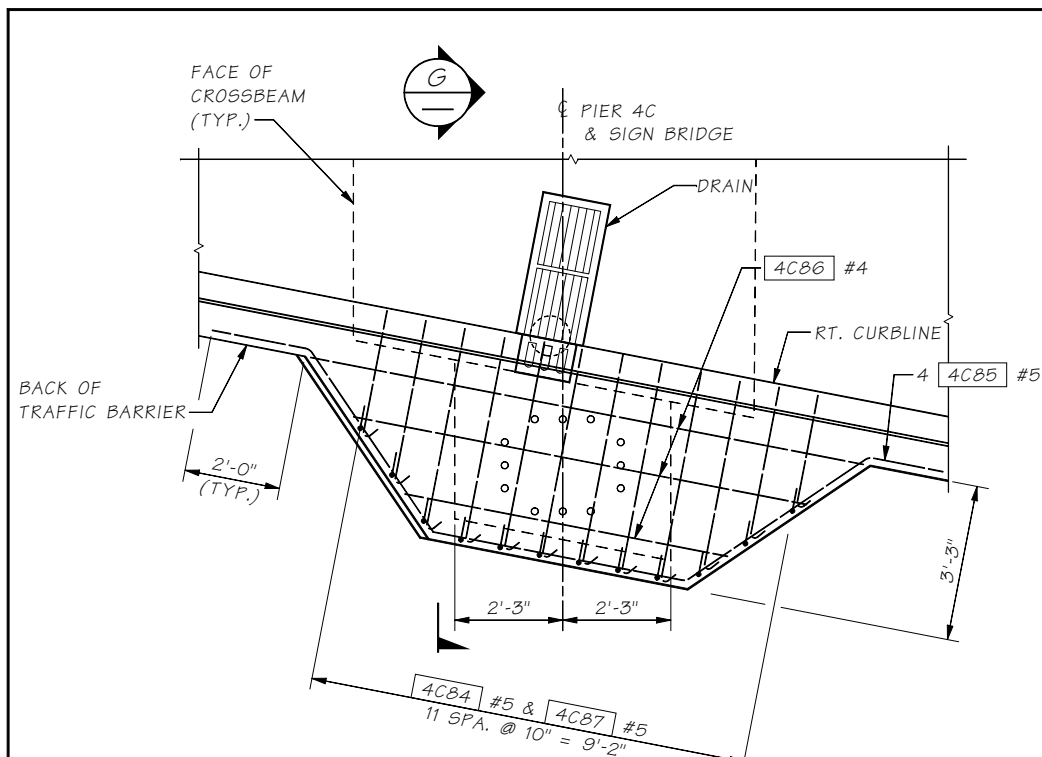

PLAN VIEW

RT. CURBLINE SHOWN,
LT. CURBLINE SIMILAR

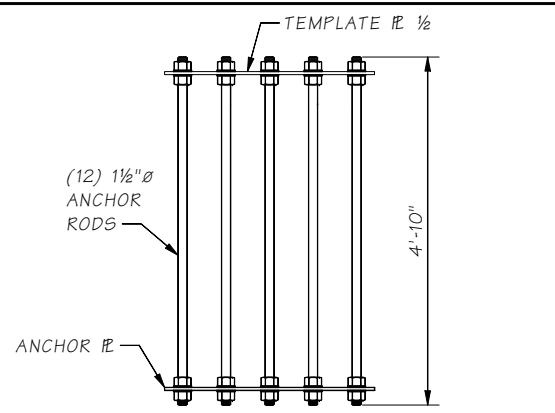

ANCHOR BOLT ASSEMBLY

PLATE STEEL SHALL CONFORM TO ASTM A36
ANCHOR RODS SHALL CONFORM TO ASTM F1554 GR. 105.
SEE SIGN BRIDGE DETAILS

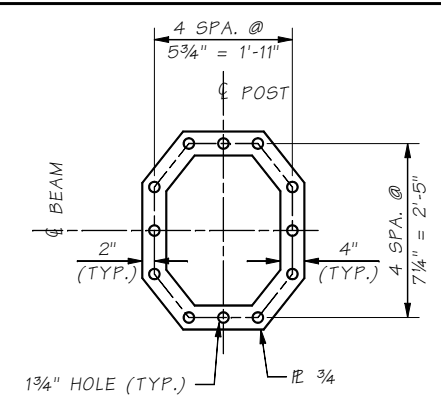

ANCHOR PLATE DETAIL

TEMPLATE PLATE SIMILAR

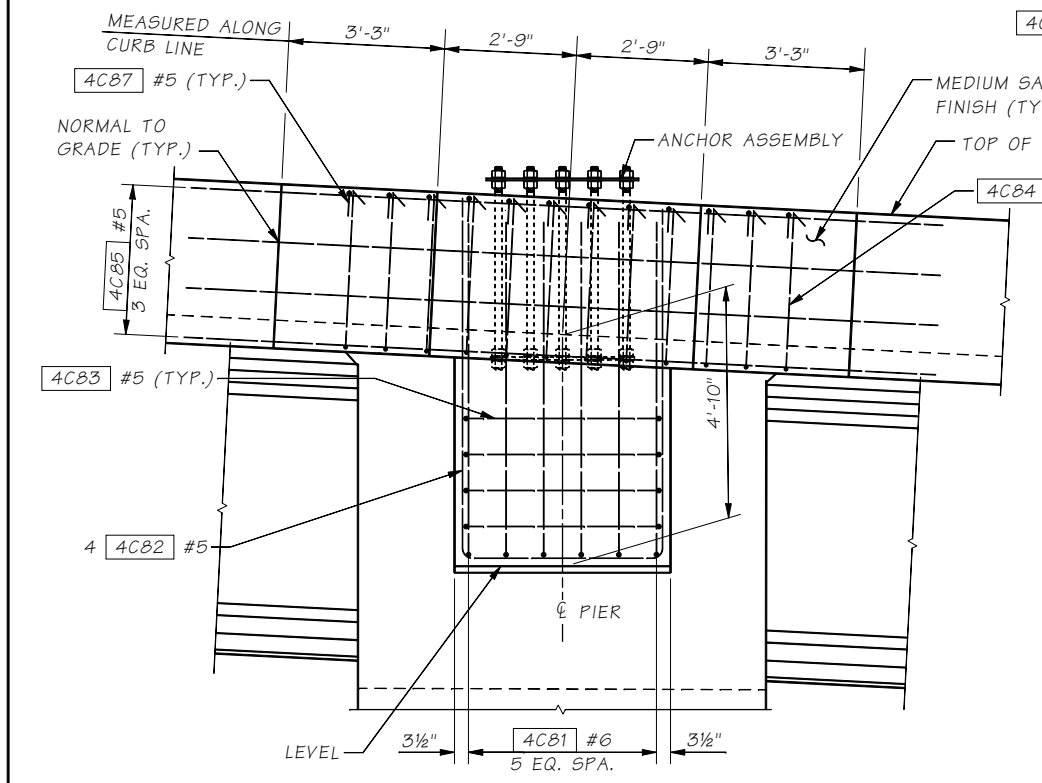
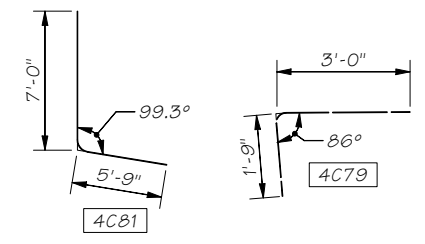

ELEVATION

RT. CURBLINE SHOWN,
LT. CURBLINE SIMILAR

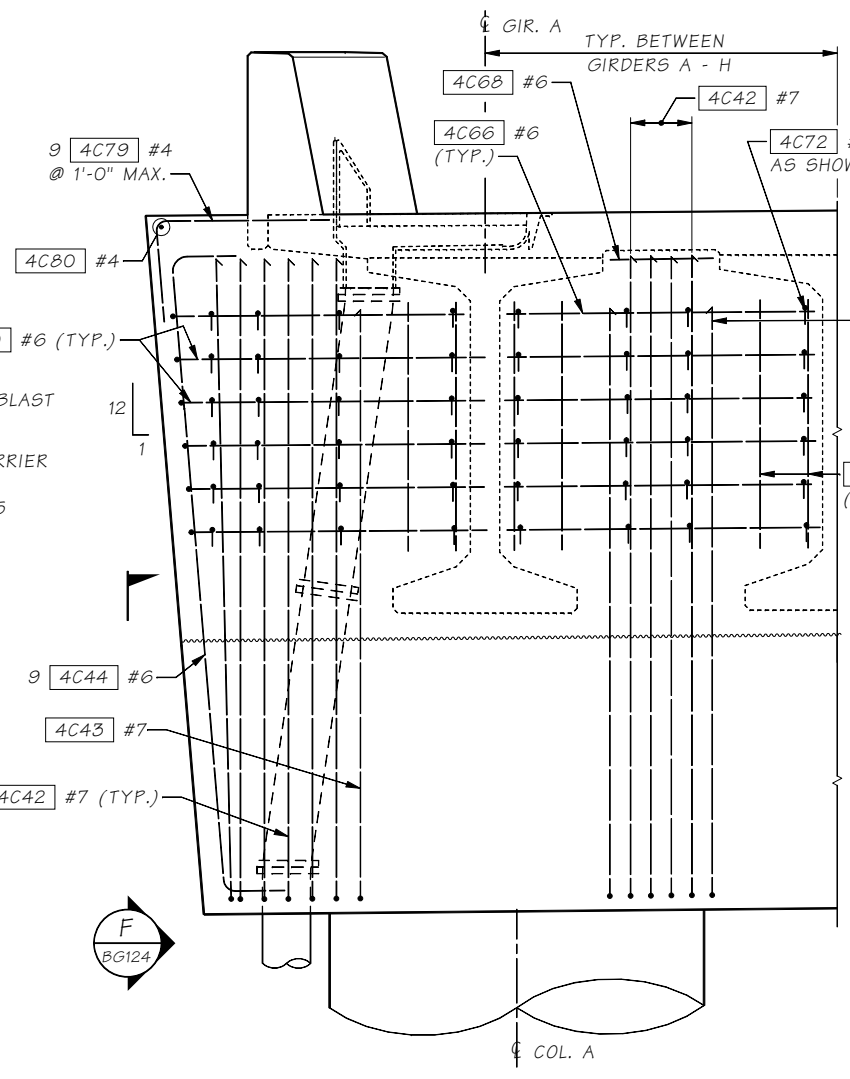

END DETAIL

LT. END

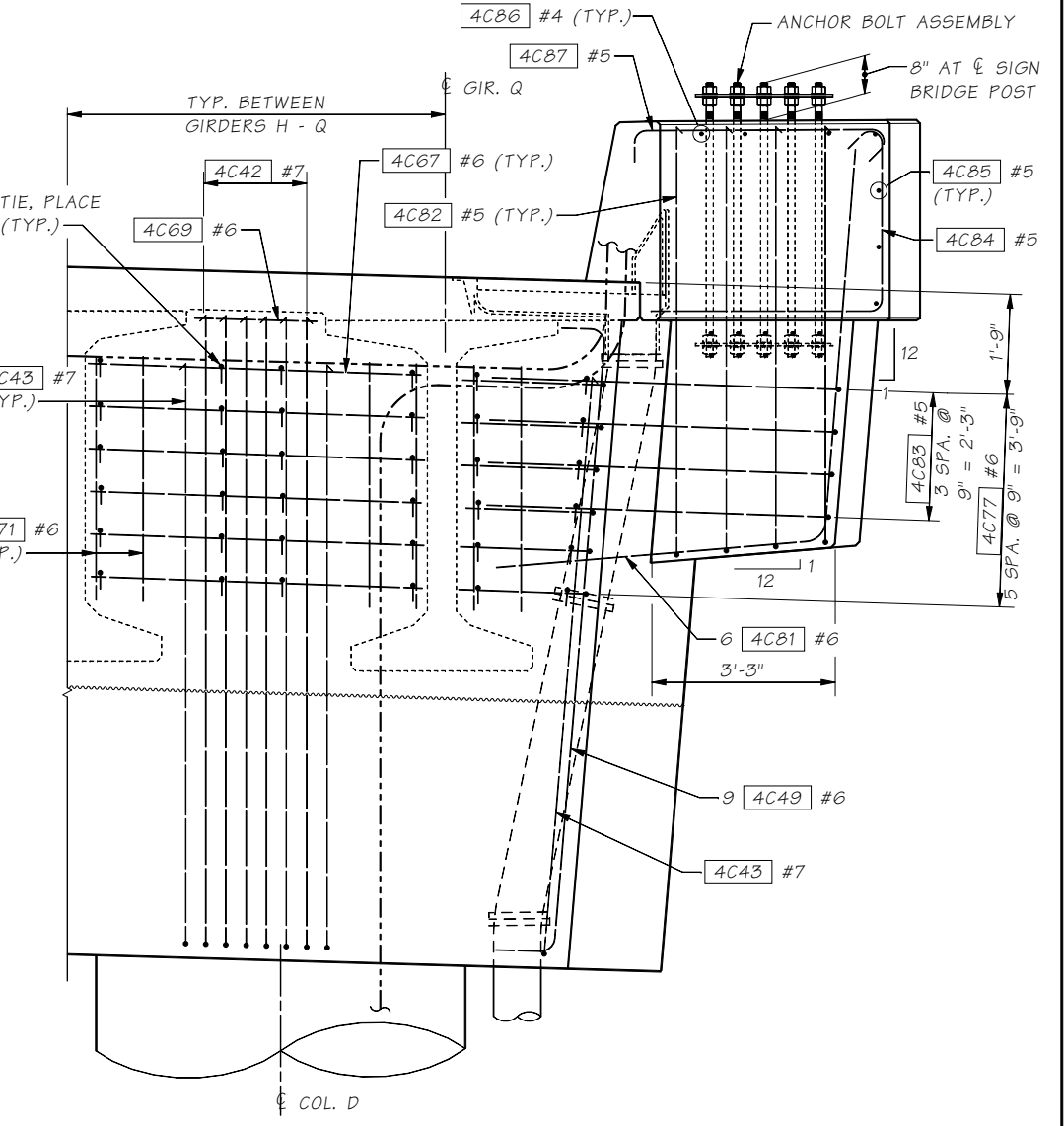

SECTION G

RT. END

SR 99 FILE NO. SHEET BG125

Bridge Design Engr. Khaleghi, B	M:\Y-Team\AWV SOUTH INTERCHANGE\window files\PIER 4C CROSSBEAM 3.WND				REGION NO.	STATE	FED. AID PROJ. NO.	SHEET NO.	TOTAL SHEETS
Supervisor Moore, TM					10	WASH.			
Designed By Mizumori, A	05/09								
Checked By Talukdar, M	09/09								
Detailed By Evans, A	05/09								
Bridge Projects Engr.					JOB NUMBER				
Prelim. Plan By					09A803				
Architect/Specialist	DATE	REVISION	BY	APPD					



BRIDGE AND STRUCTURES OFFICE

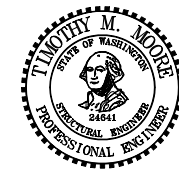

SR 99
ALASKAN WAY VIADUCT - REPLACEMENT
S HOLGATE ST TO S KING ST - PHASE 2
BRIDGE NO. 99/540 NB & SB
PIER 4C CROSSBEAM DETAILS 3 OF 3

BRIDGE SHEET NO. BG125
SHEET 971 OF 1475 SHEETS

SR 99 FILE NO. SHEET BG126

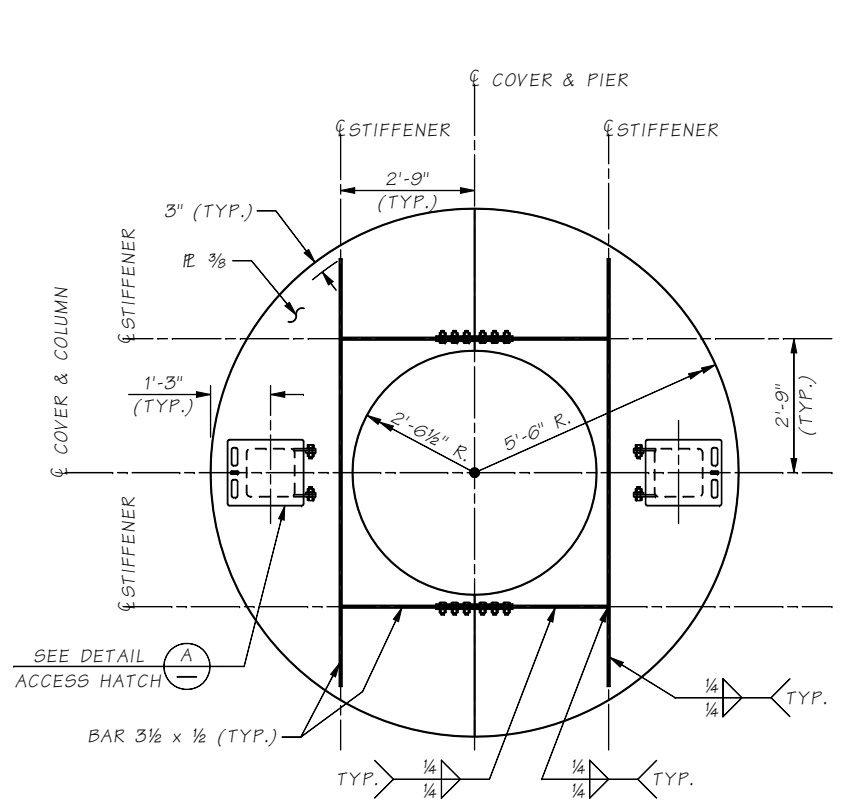

PLAN - CASING COVER
REQUIRED AT PIERS 5C & 6C - 8 TOTAL.

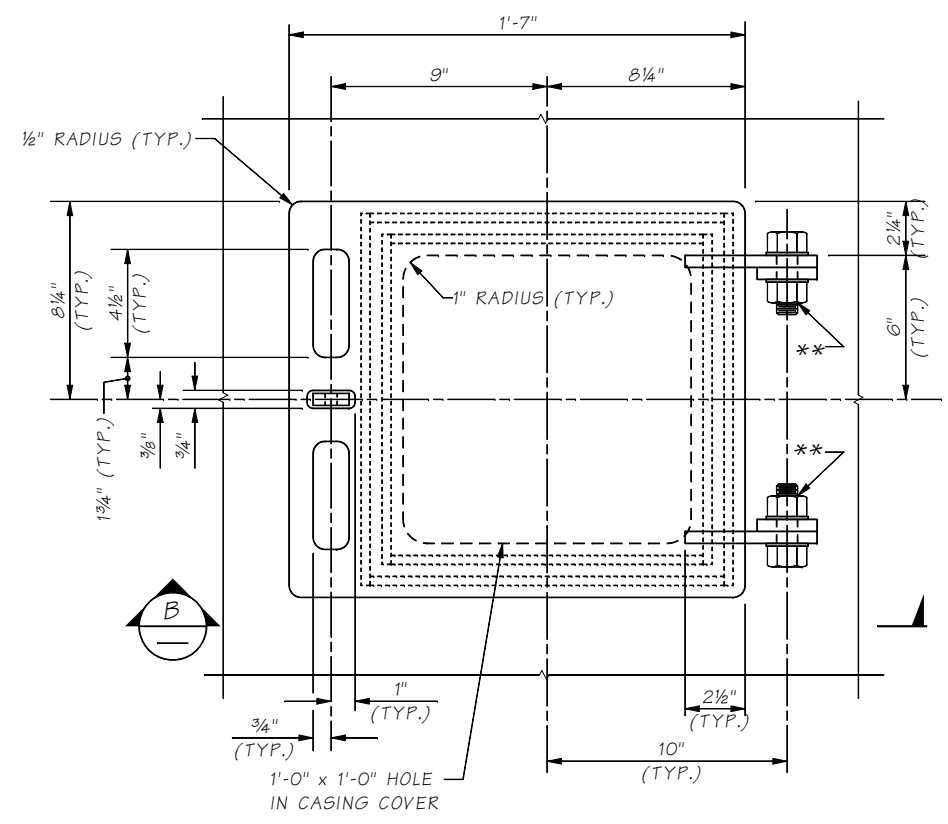

DETAIL A
ACCESS HATCH

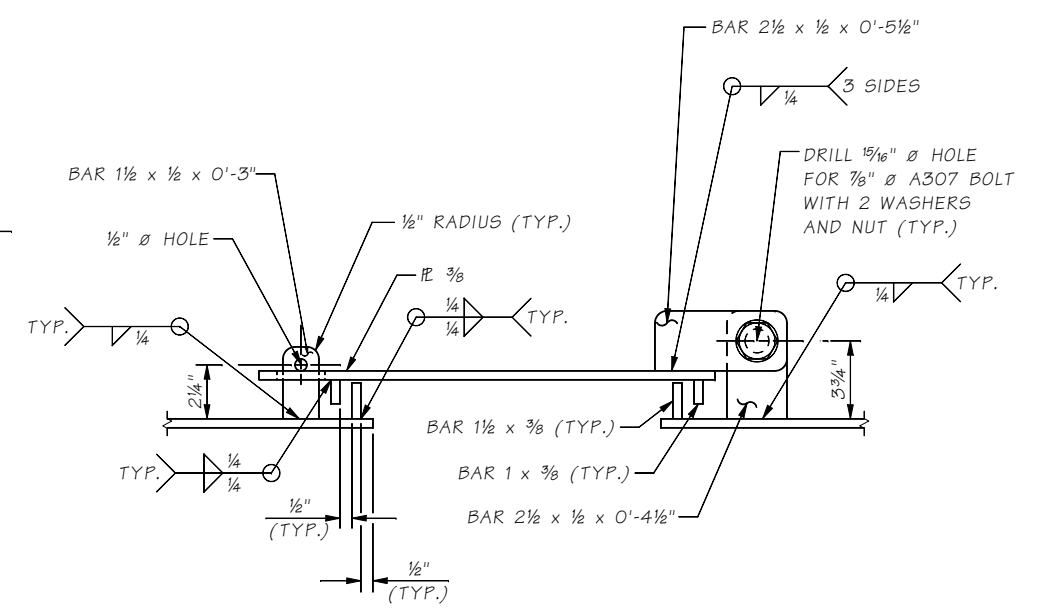

SECTION B

** INSTALL NUT SO THAT HATCH OPENS FREELY. TACK WELD NUT TO BOLT. APPLY TWO COATS OF GALVANIZING REPAIR PAINT FORMULA A-9-73.

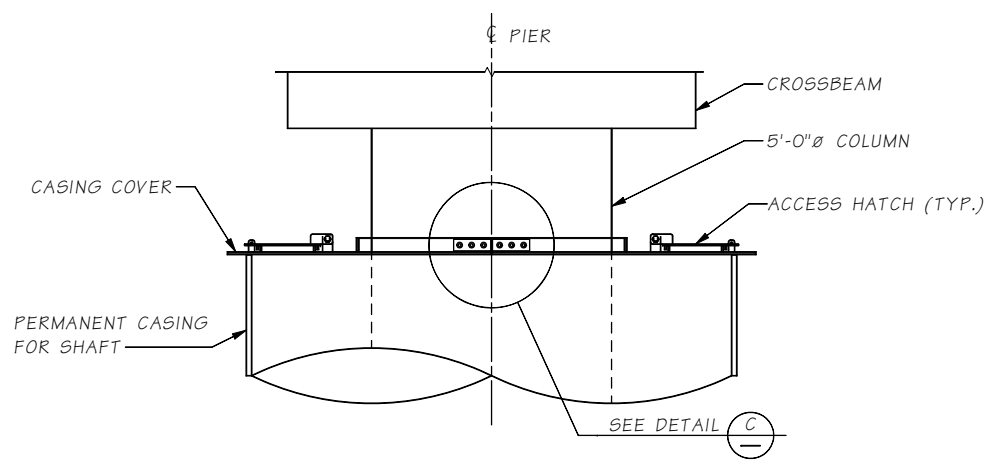

CASING COVER DETAIL
THE CONTRACTOR SHALL VERIFY THAT THE COVER FITS OVER THE ACTUAL SHAFT PERMANENT CASING.

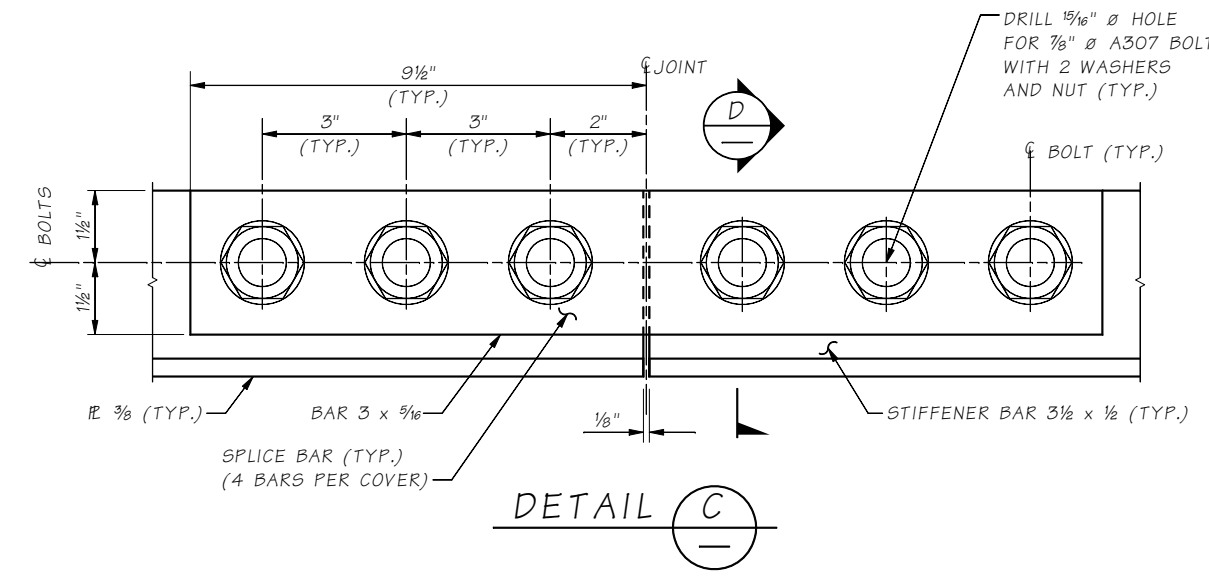

DETAIL C

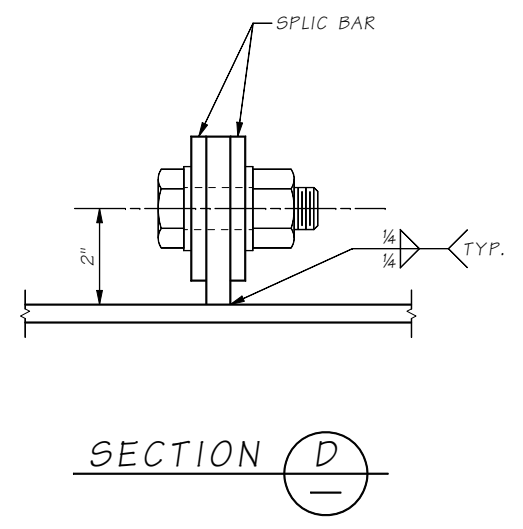

SECTION D

NOTE:
CASING COVER, ACCESS HATCH, AND ALL HARDWARE SHALL BE HOT DIP GALVANIZED AFTER FABRICATION AND THE TOP SURFACES SHALL BE PAINTED PER STANDARD SPECIFICATION SECTION 6-07.3(4).

Bridge Design Engr.	Khaleghi, B	M:\Y-Team\AWV SOUTH INTERCHANGE\window files\Pier and Casing Dtls.WND			
Supervisor	Moore, TM	REGION NO.	STATE	FED. AID PROJ. NO.	SHEET NO.
Designed By	Schultz, E	10	WASH.		TOTAL SHEETS
Checked By	Mizumori, A	JOB NUMBER 09A803			
Detailed By	Schultz, E				
Bridge Projects Engr.					
Prelim. Plan By					
Architect/Specialist		DATE	REVISION	BY	APPD



BRIDGE AND STRUCTURES OFFICE

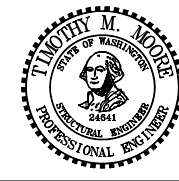

SR 99
ALASKAN WAY VIADUCT - REPLACEMENT
S HOLGATE ST TO S KING ST - PHASE 2
BRIDGE NO. 99/540 NB & SB

PIER AND CASING DETAILS

BRIDGE SHEET NO. BG126
SHEET 972 OF 1475 SHEETS

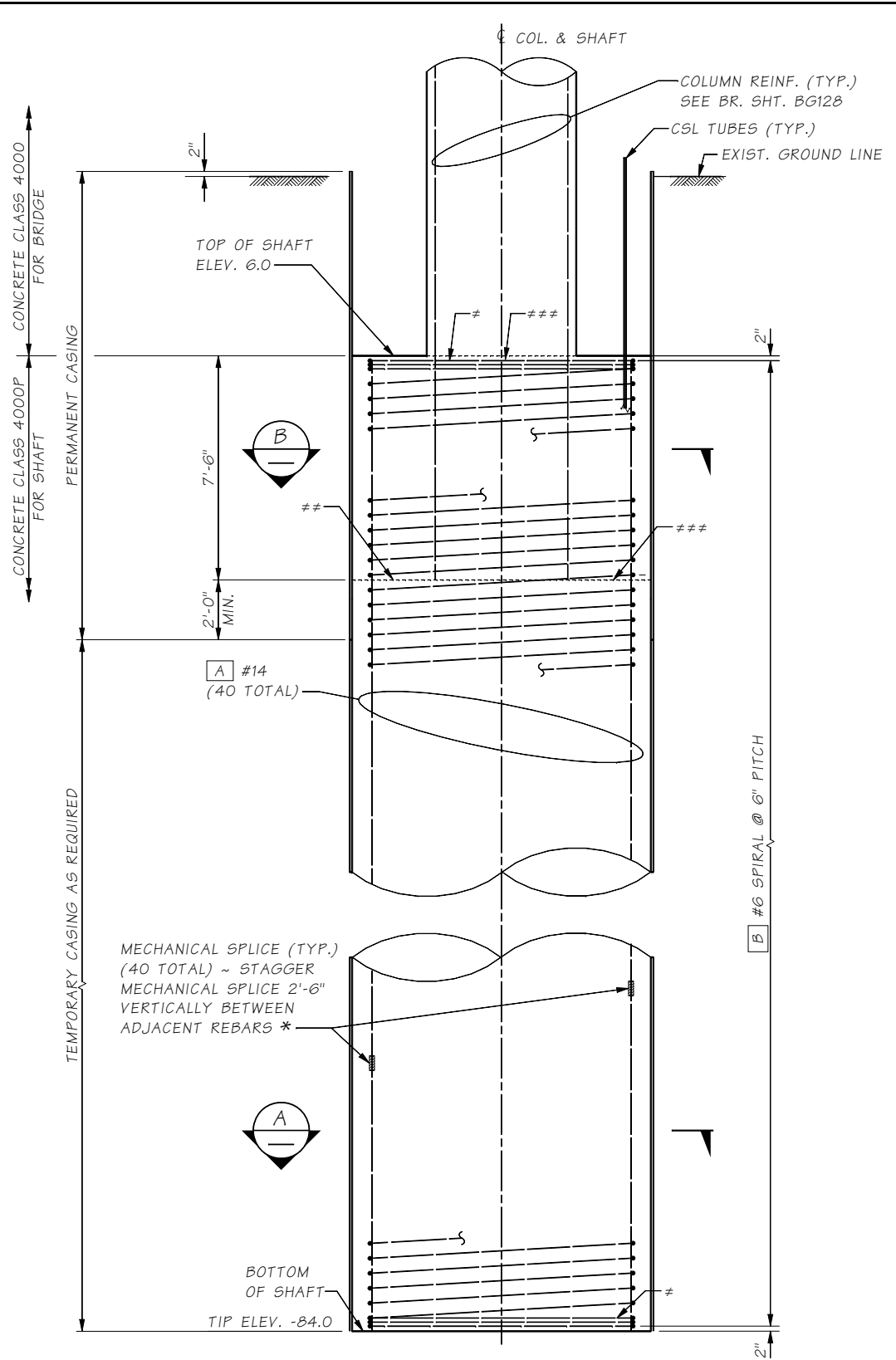

ELEVATION

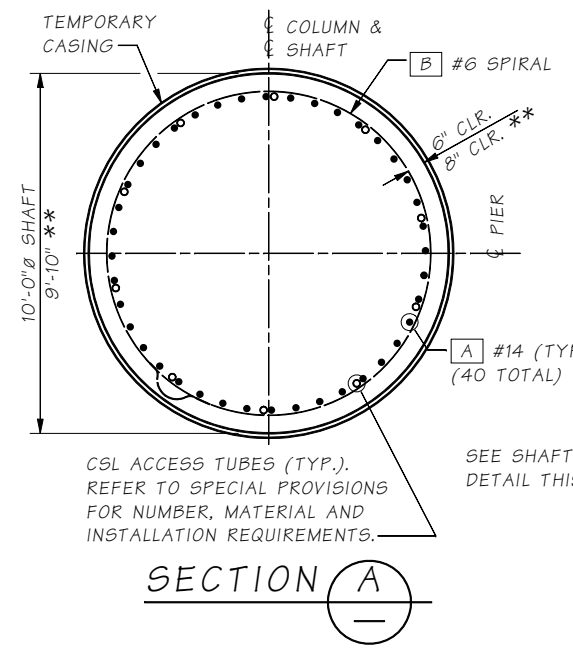

SECTION A

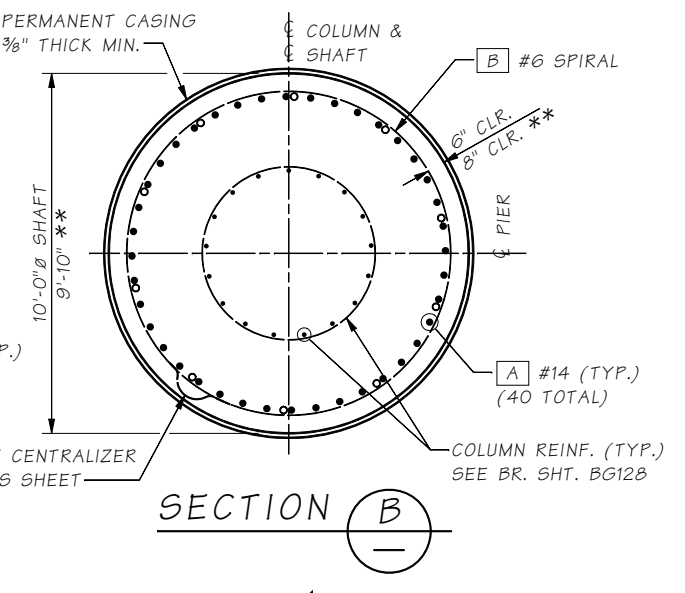

SECTION B

- * MECHANICAL SPLICE SHALL MEET THE REQUIREMENTS OF STD. SPEC. 6-02.3(24)F
- ** SHAFT CONSTRUCTED WITH THE OSCILLATOR METHOD. THE CONTRACTOR SHALL REVISE THE SHAFT BARLIST IF THE OSCILLATOR METHOD IS CHOSEN FOR SHAFT CONSTRUCTION
- # SEE SPIRAL TERMINATION DETAIL THIS SHEET
- ## REMOVE SEDIMENT LAITENCE & WEAK CONCRETE TO SOUND CONCRETE PRIOR TO SETTING COLUMN REINFORCEMENT
- ### CONST. JOINT WITH ROUGHENED SURFACE

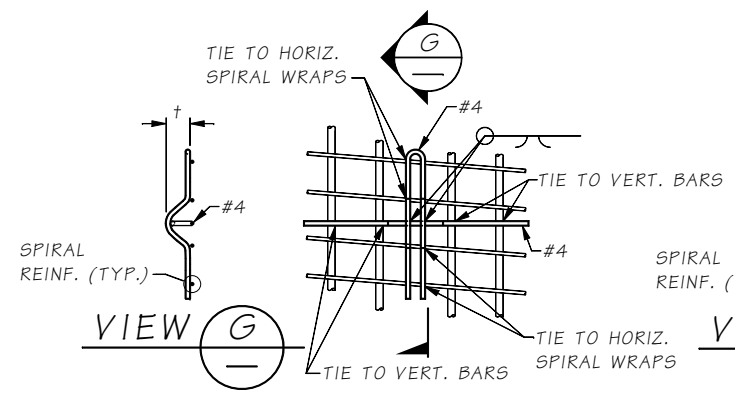

CENTRALIZER DETAIL

EPOXY COAT CENTRALIZER OR PAINT WITH INORGANIC ZINC AFTER FABRICATION (OPTION 1)

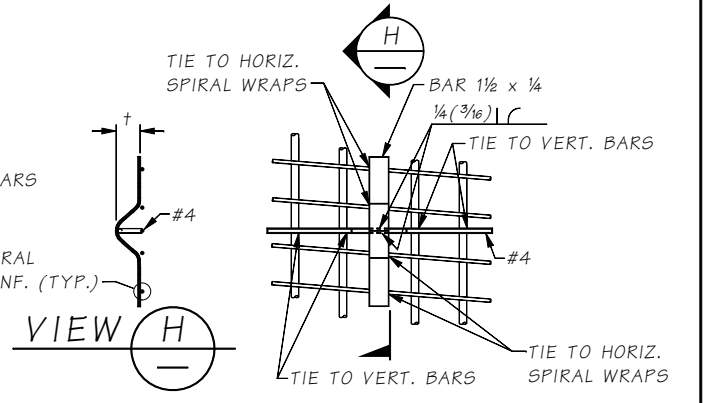

CENTRALIZER DETAIL

EPOXY COAT CENTRALIZER OR PAINT WITH INORGANIC ZINC AFTER FABRICATION (OPTION 2)

- NOTES:
1. EACH LEG SHOULD BE TIED TO TWO VERTICAL BARS OR TWO SPIRALS.
 2. SEE SPECIAL PROVISIONS FOR SPACING REQUIREMENTS.
 3. † CONCRETE COVER MINUS 1/8"

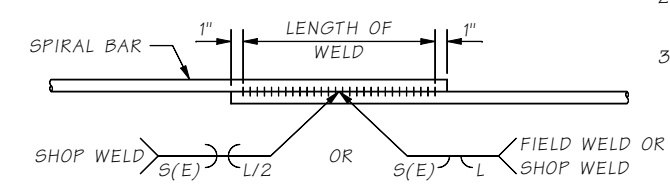

WELDED LAP SPLICE DETAIL

WELDING SHALL MEET THE REQUIREMENTS OF STD. SPEC. 6-02.3(24)E FOR WELD DIMENSIONS SEE TABLE BELOW.

SPIRAL INFORMATION			
DEFORMED BAR ASTM A 706	WELD DEMENSIONS		
	S	E	LENGTH (L)
#6 SPIRAL	3/8"	3/16"	6"

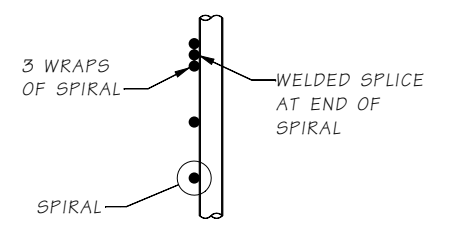

SPIRAL TERMINATION DETAIL

SHAFT BAR LIST

ALL REINFORCING SHALL BE ASTM A 706
QUANTITIES ARE PER SHAFT

MARK	SIZE	NO.	LENGTH	BEND TYPE	WT. (lbs.)
A	#14	40	89'-9"	STR.	27,462
B	#6	1	5092'-0"	67	7,647
TOTAL					35,109

(a) ~ DETERMINED FROM PLANS
WEIGHT INCLUDES SPLICES

SPIRAL (BEND TYPE 67)

SR 99 FILE NO. SHEET BG127

Bridge Design Engr. Khaleghi, B	M:\Y-Team\AWV SOUTH INTERCHANGE\window files\Pier 5C Shaft Dtls.WND	REGION NO.	STATE	FED. AID PROJ. NO.	SHEET NO.	TOTAL SHEETS
Supervisor Moore, TM		10	WASH.			
Designed By Talukdar, M	10/08					
Checked By Mizumori, A	08/09					
Detailed By Evans, A	10/08					
Bridge Projects Engr.						
Prelim. Plan By						
Architect/Specialist	DATE	REVISION	BY	APPD		



BRIDGE AND STRUCTURES OFFICE



SR 99
ALASKAN WAY VIADUCT - REPLACEMENT
S HOLGATE ST TO S KING ST - PHASE 2
BRIDGE NO. 99/540 NB & SB

PIER 5C SHAFT DETAILS

BRIDGE SHEET NO. BG127
SHEET 973 OF 1475 SHEETS

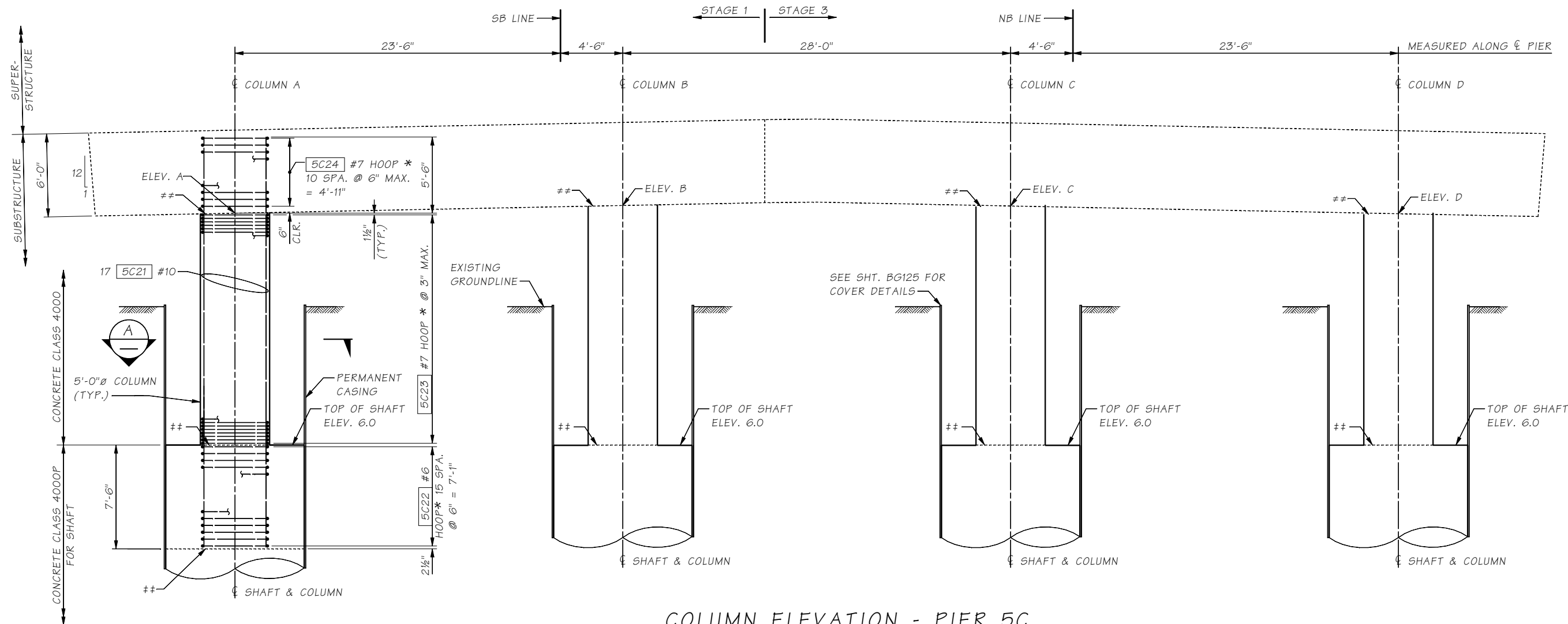

COLUMN ELEVATION - PIER 5C

TABLE OF ELEVATIONS	
TOP OF COLUMN	ELEVATION
ELEV. A	22.75
ELEV. B	23.31
ELEV. C	23.27
ELEV. D	22.71

* HOOP WELD SHALL BE DIRECT BUTT-WELDED AND CONFORM TO THE CURRENT EDITION OF STRUCTURAL WELDING CODE - REINFORCING STEEL OF AWS(D1.4) AND MEET THE REQUIREMENTS OF STD. SPEC. 6-02.3(24) RESISTANCE BUTT WELDED SPLICE MAY BE SUBSTITUTED AT THE CONTRACTOR'S OPTION. SEE SPECIAL PROVISIONS.

CONSTRUCTION JOINT w/ ROUGHENED SURFACE

NOTE:
COLUMN DETAILS & REINFORCING
TYPICAL FOR ALL COLUMNS.

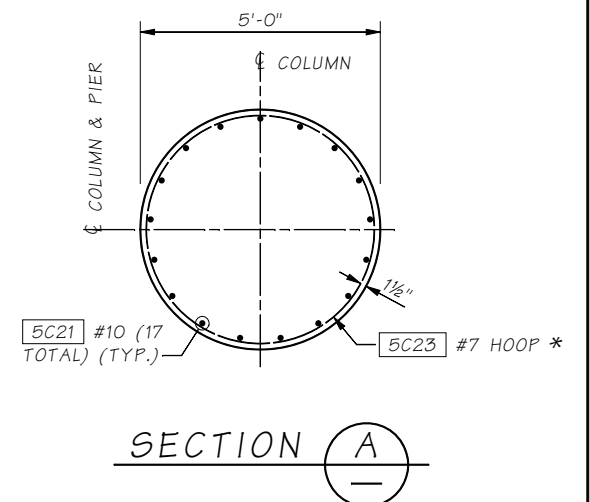
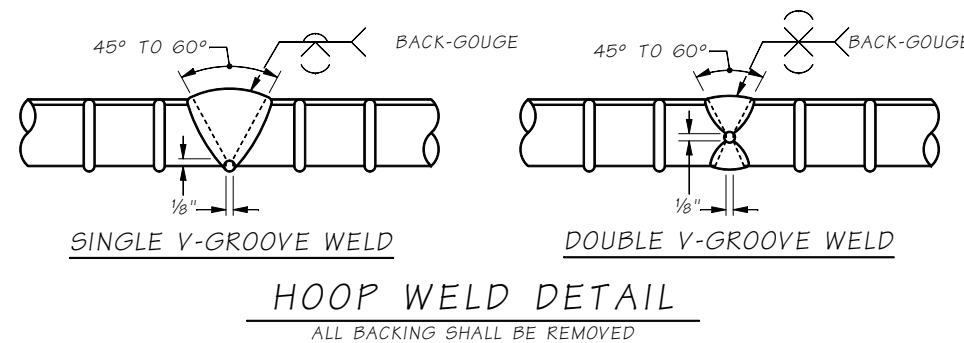

SR 99 FILE NO. SHEET BG128

Bridge Design Engr. Khaleghi, B	M:\Y-Team\AWV SOUTH INTERCHANGE\window files\PIER 5C COLUMN.WND				REGION NO.	STATE	FED. AID PROJ. NO.	SHEET NO.	TOTAL SHEETS
Supervisor Moore, TM					10	WASH.			
Designed By Mizumori, A	10/08								
Checked By Talukdar, M	08/09								
Detailed By Evans, A	10/08								
Bridge Projects Engr.					JOB NUMBER				
Prelim. Plan By					09A803				
Architect/Specialist	DATE	REVISION	BY	APPD					



BRIDGE AND STRUCTURES OFFICE

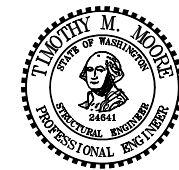

SR 99
ALASKAN WAY VIADUCT - REPLACEMENT
S HOLGATE ST TO S KING ST - PHASE 2
BRIDGE NO. 99/540 NB & SB
PIER 5C COLUMN DETAILS

BRIDGE SHEET NO. BG128
SHEET 974 OF 1475 SHEETS

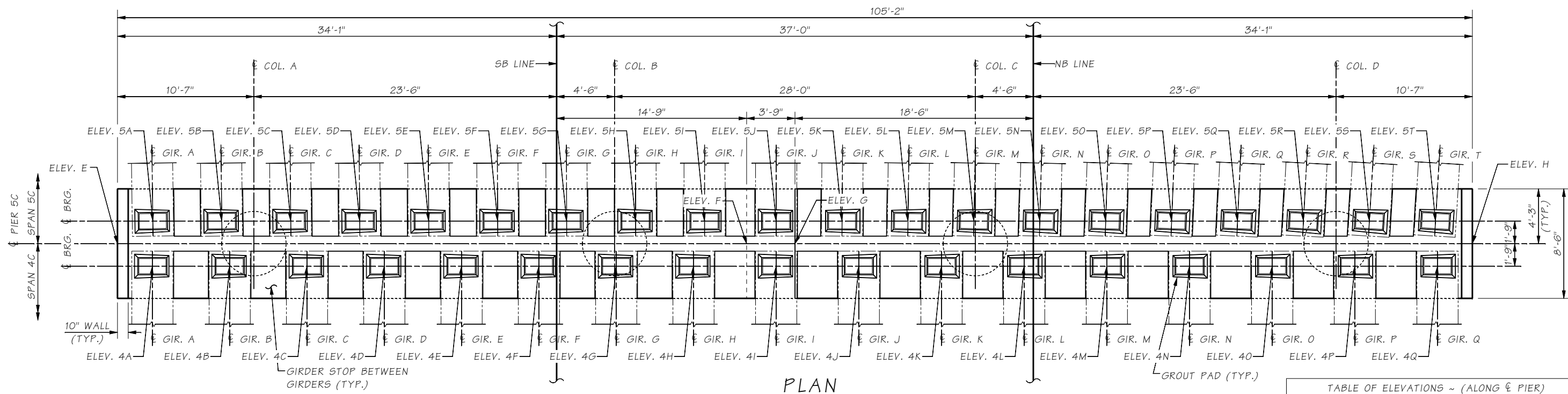

PLAN

NOTE:
SEE FRAMING PLAN FOR GIRDER SPACING

TABLE OF ELEVATIONS ~ (ALONG C PIER)			
LOCATION	ELEVATION	LOCATION	ELEVATION
E	28.54	J	36.09
F	29.51	K	37.12
G	29.55	L	37.08
H	28.50	M	36.05

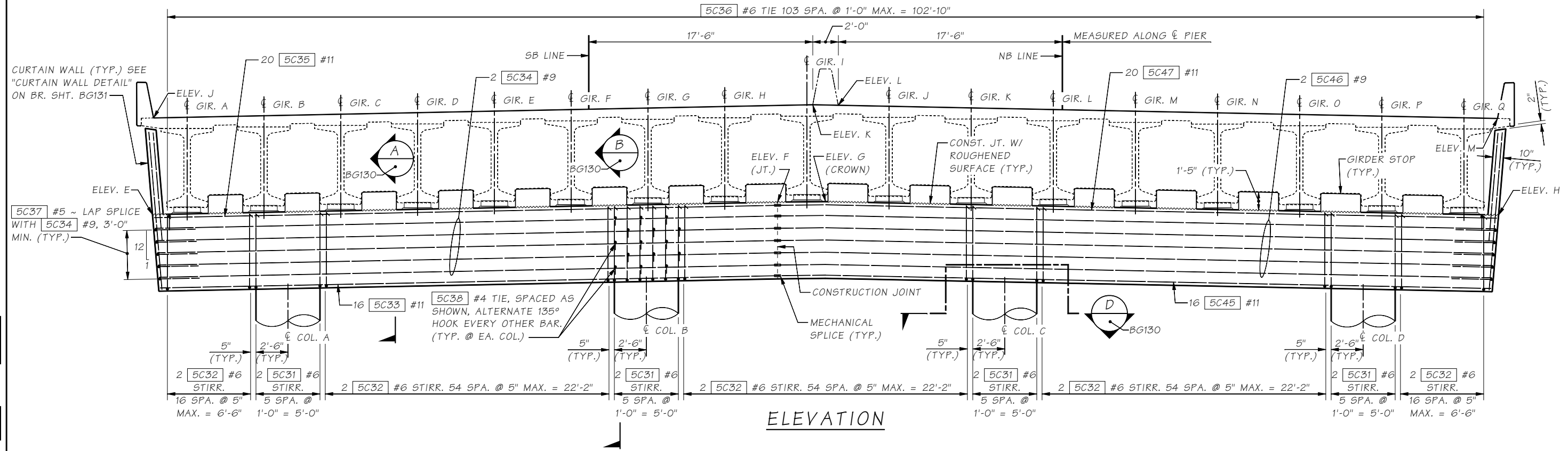

ELEVATION

SR 99 FILE NO. SHEET BG129

Bridge Design Engr.	Khaleghi, B	M:\Y-Team\AWW SOUTH INTERCHANGE\window files\Pier 5C X-Beam Plan-Elev.WND			
Supervisor	Moore, TM	REGION NO.	STATE	FED. AID PROJ. NO.	SHEET NO.
Designed By	Mizumori, A 05/09	10	WASH.		TOTAL SHEETS
Checked By	Rodda, NT 08/09	JOB NUMBER 09A803			
Detailed By	Evans, A 05/09				
Bridge Projects Engr.					
Prelim. Plan By					
Architect/Specialist		DATE	REVISION	BY	APPD

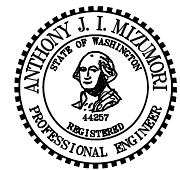

BRIDGE AND STRUCTURES OFFICE

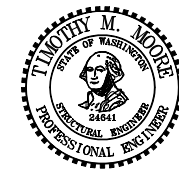

SR 99
ALASKAN WAY VIADUCT - REPLACEMENT
S HOLGATE ST TO S KING ST - PHASE 2
BRIDGE NO. 99/540 NB & SB
PIER 5C CROSSBEAM
PLAN AND ELEVATION

BRIDGE SHEET NO. BG129
SHEET 975 OF 1475 SHEETS

SPAN 4C GIRDERS (SB)	4A	4B	4C	4D	4E	4F	4G	4H	4I	
	28.71	28.83	28.95	29.07	29.19	29.31	29.43	29.55	29.68	
SPAN 4C GIRDERS (NB)	4J	4K	4L	4M	4N	4O	4P	4Q		
	29.58	29.45	29.32	29.19	29.06	28.93	28.81	28.68		
SPAN 5C GIRDERS (SB)	5A	5B	5C	5D	5E	5F	5G	5H	5I	5J
	28.81	28.92	29.03	29.13	29.24	29.35	29.45	29.56	29.67	29.78
SPAN 5C GIRDERS (NB)	5K	5L	5M	5N	5O	5P	5Q	5R	5S	5T
	29.70	29.60	29.49	29.39	29.29	29.19	29.09	28.98	28.88	28.78

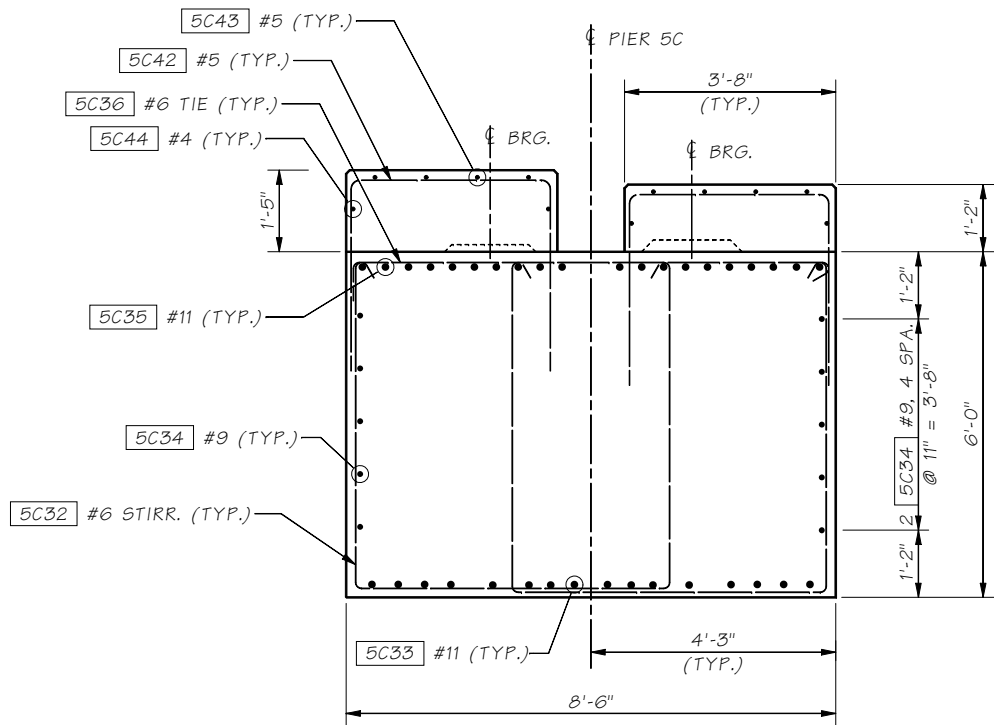

SECTION A
STAGE 1 SHOWN,
STAGE 2 SIMILAR

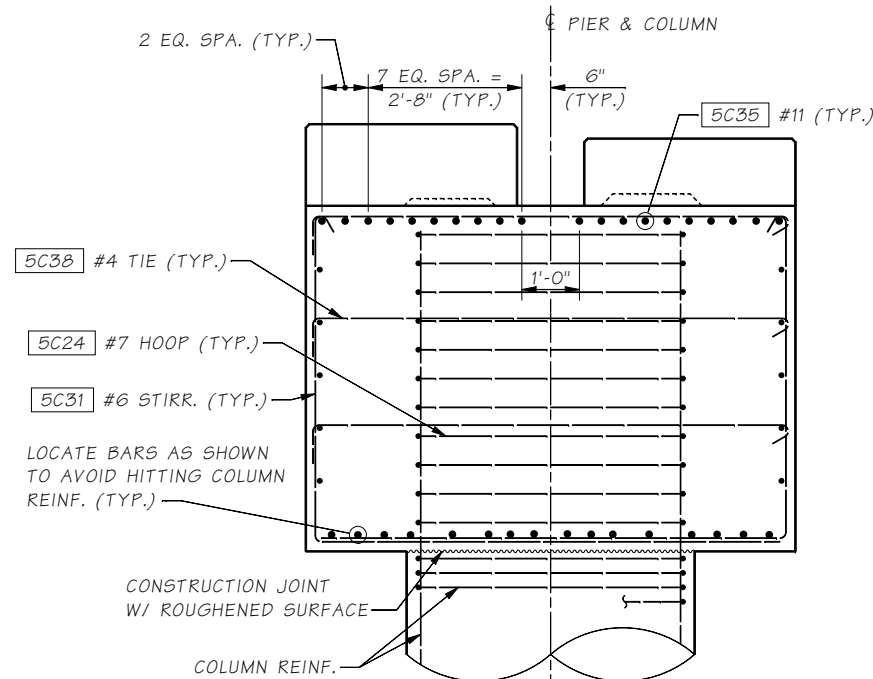

SECTION B
SHOWN @ COL. B
SIMILAR AT OTHER COLUMNS

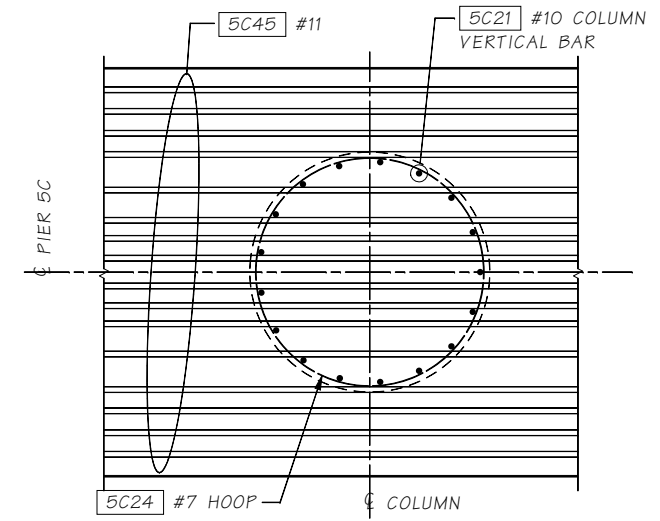

SECTION D
TRANSVERSE REINFORCING
NOT SHOWN FOR CLARITY.
ADJUST LONGITUDINAL BAR,
TRANSVERSE STIRRUP, AND THE TIE SPACING
AS REQUIRED TO CLEAR COLUMN VERTICAL BARS.

SR 99 FILE NO. SHEET BG130

Bridge Design Engr.	Khaleghi, B	M:\Y-Team\AWV SOUTH INTERCHANGE\window files\PIER 5C CROSSBEAM I.WND				REGION NO.	STATE	FED. AID PROJ. NO.	SHEET NO.	TOTAL SHEETS
Supervisor	Moore, TM					10	WASH.			
Designed By	Mizumori, A	10/08								
Checked By	Rodda, NT	08/09								
Detailed By	Evans, A	10/08								
Bridge Projects Engr.										
Prelim. Plan By										
Architect/Specialist		DATE	REVISION	BY	APPD					



BRIDGE AND STRUCTURES OFFICE

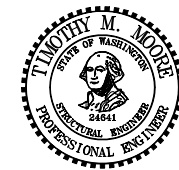

SR 99
ALASKAN WAY VIADUCT - REPLACEMENT
S HOLGATE ST TO S KING ST - PHASE 2
BRIDGE NO. 99/540 NB & SB
PIER 5C CROSSBEAM DETAILS 1 OF 2

BRIDGE SHEET NO. BG130
SHEET 976 OF 1475 SHEETS

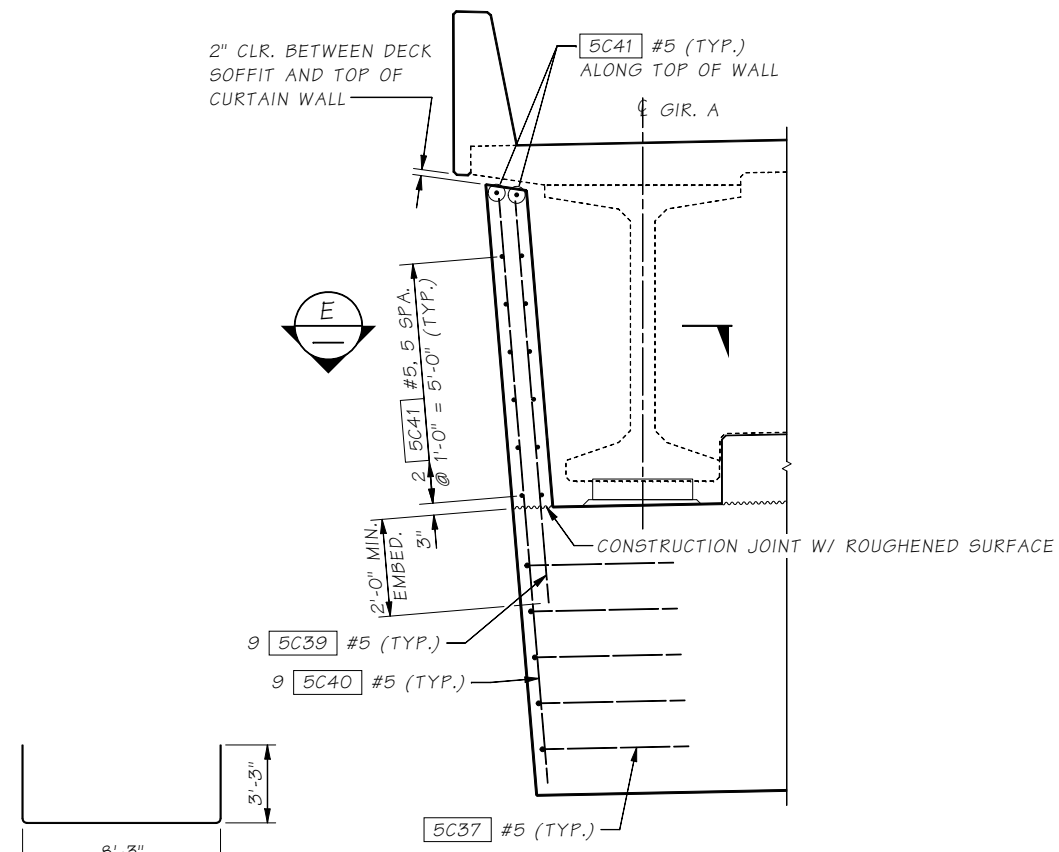

CURTAIN WALL DETAIL

CROSSBEAM REINFORCING NOT SHOWN FOR CLARITY

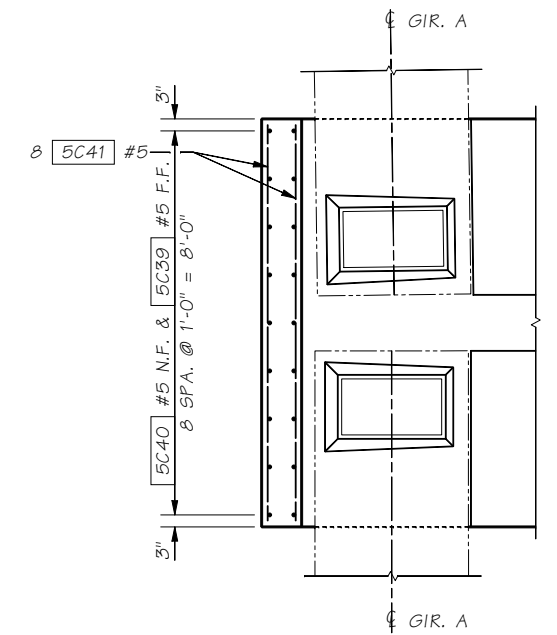
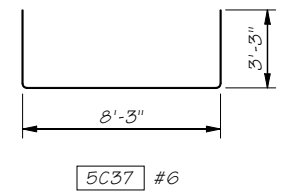

SECTION E

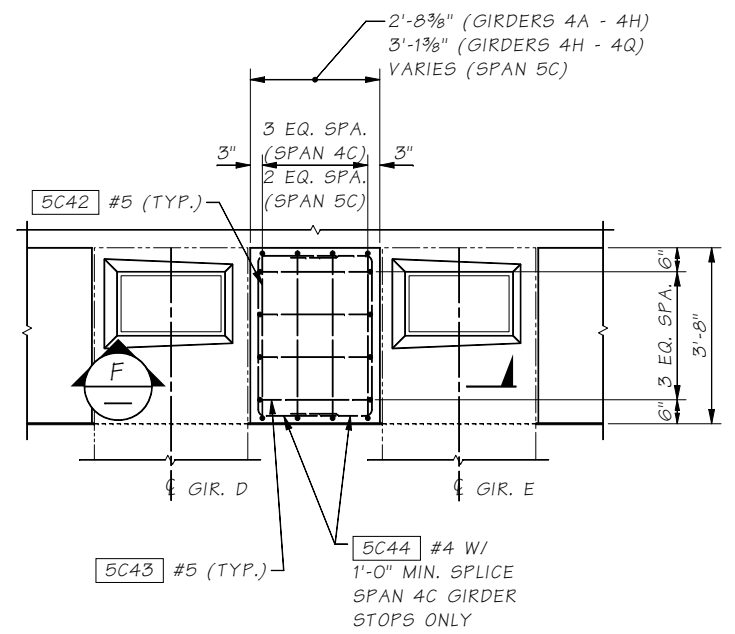

GIRDER STOP DETAIL

SEE "BEARING DETAILS"

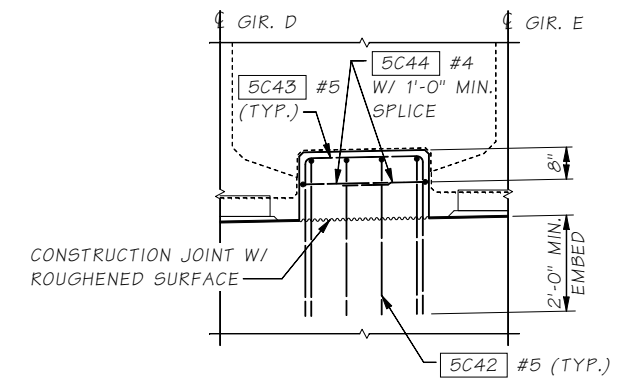

SECTION F

SR 99 FILE NO. SHEET BG131

Bridge Design Engr.	Khaleghi, B	M:\Y-Team\AWV SOUTH INTERCHANGE\window files\PIER 5C CROSSBEAM 2.WND			
Supervisor	Moore, TM	REGION NO.	STATE	FED. AID PROJ. NO.	SHEET NO.
Designed By	Mizumori, A 10/08	10	WASH.		TOTAL SHEETS
Checked By	Rodda, NT 08/09	JOB NUMBER 09A803			
Detailed By	Evans, A 10/08				
Bridge Projects Engr.					
Prelim. Plan By					
Architect/Specialist		DATE	REVISION	BY	APPD

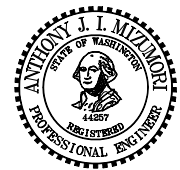

BRIDGE AND STRUCTURES OFFICE

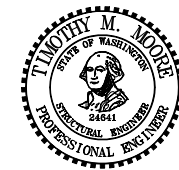

SR 99
ALASKAN WAY VIADUCT - REPLACEMENT
S HOLGATE ST TO S KING ST - PHASE 2
BRIDGE NO. 99/540 NB & SB
PIER 5C CROSSBEAM DETAILS 2 OF 2

BRIDGE SHEET NO. BG131
SHEET 977 OF 1475 SHEETS

SR 99 FILE NO. SHEET BG132

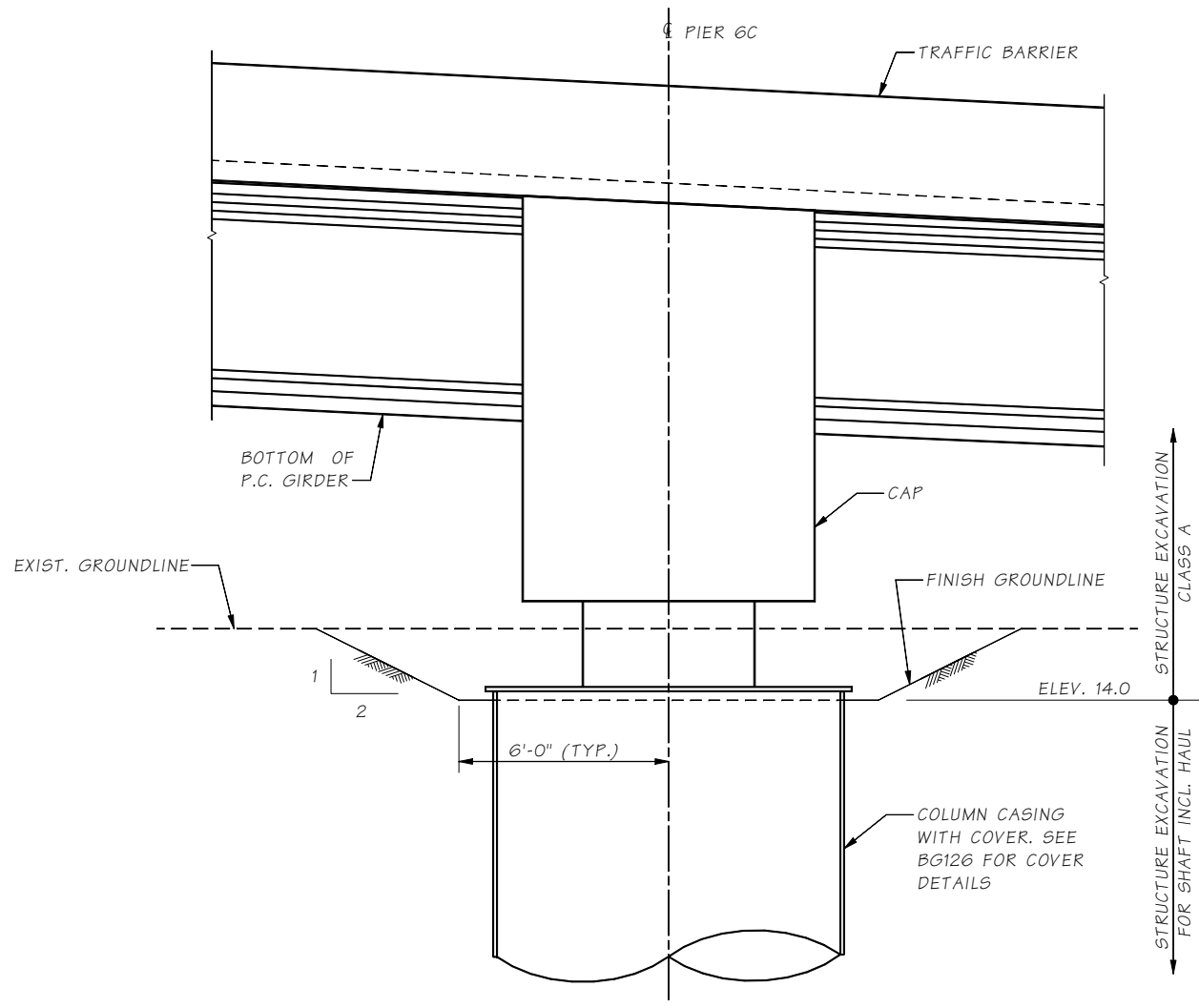

DETAIL - PIER 6C EXCAVATION

TYPICAL ALONG LENGTH OF PIER 6C.
 THE BOTTOM FACE OF CAP SHALL BE FORMED. THE CONTRACTOR MAY ELECT TO EXCAVATE UNDER THE CAP AFTER THE CAP FORMS ARE REMOVED.
 SEE BG303 FOR EXCAVATION LIMITS AT PIER 6C CATCH BASINS.

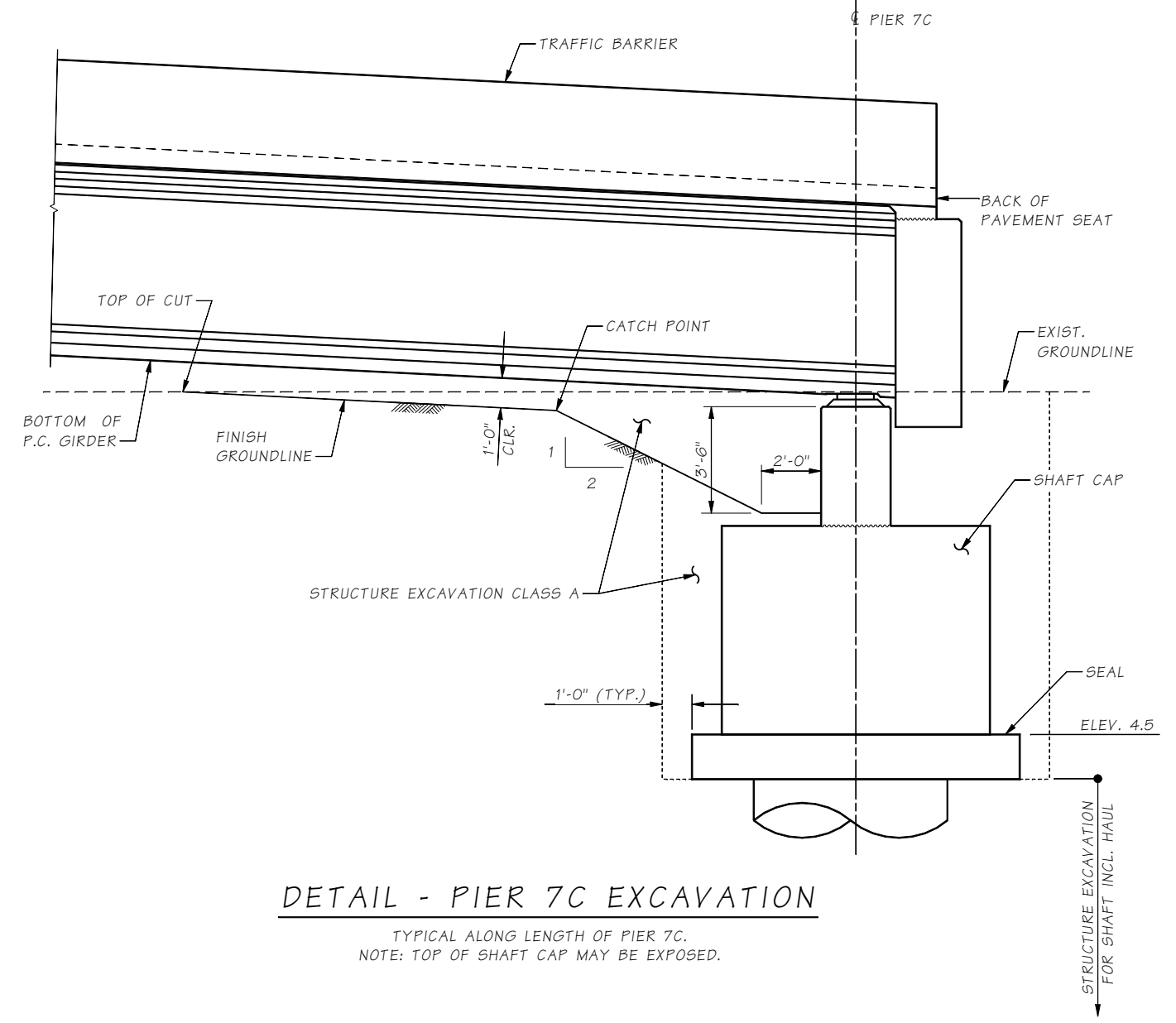

DETAIL - PIER 7C EXCAVATION

TYPICAL ALONG LENGTH OF PIER 7C.
 NOTE: TOP OF SHAFT CAP MAY BE EXPOSED.

Bridge Design Engr.	Khaleghi, B	M:\Y-Team\AWV SOUTH INTERCHANGE\window files\Pier Excavation Dtls.WND				REGION NO.	STATE	FED. AID PROJ. NO.	SHEET NO.	TOTAL SHEETS
Supervisor	Moore, TM									
Designed By	Mizumori, A	06/09			10	WASH.				
Checked By	Rodda, NT	09/09								
Detailed By	Evans, A	06/09								
Bridge Projects Engr.										
Prelim. Plan By										
Architect/Specialist		DATE	REVISION	BY	APPD					

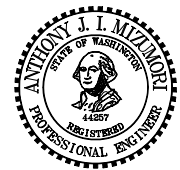

BRIDGE AND STRUCTURES OFFICE

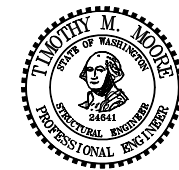

SR 99
 ALASKAN WAY VIADUCT - REPLACEMENT
 S HOLGATE ST TO S KING ST - PHASE 2
 BRIDGE NO. 99/540 NB & SB

PIER EXCAVATION DETAILS

BRIDGE SHEET NO. BG132
 SHEET 978 OF 1475 SHEETS

SR 99 FILE NO. SHEET BG133

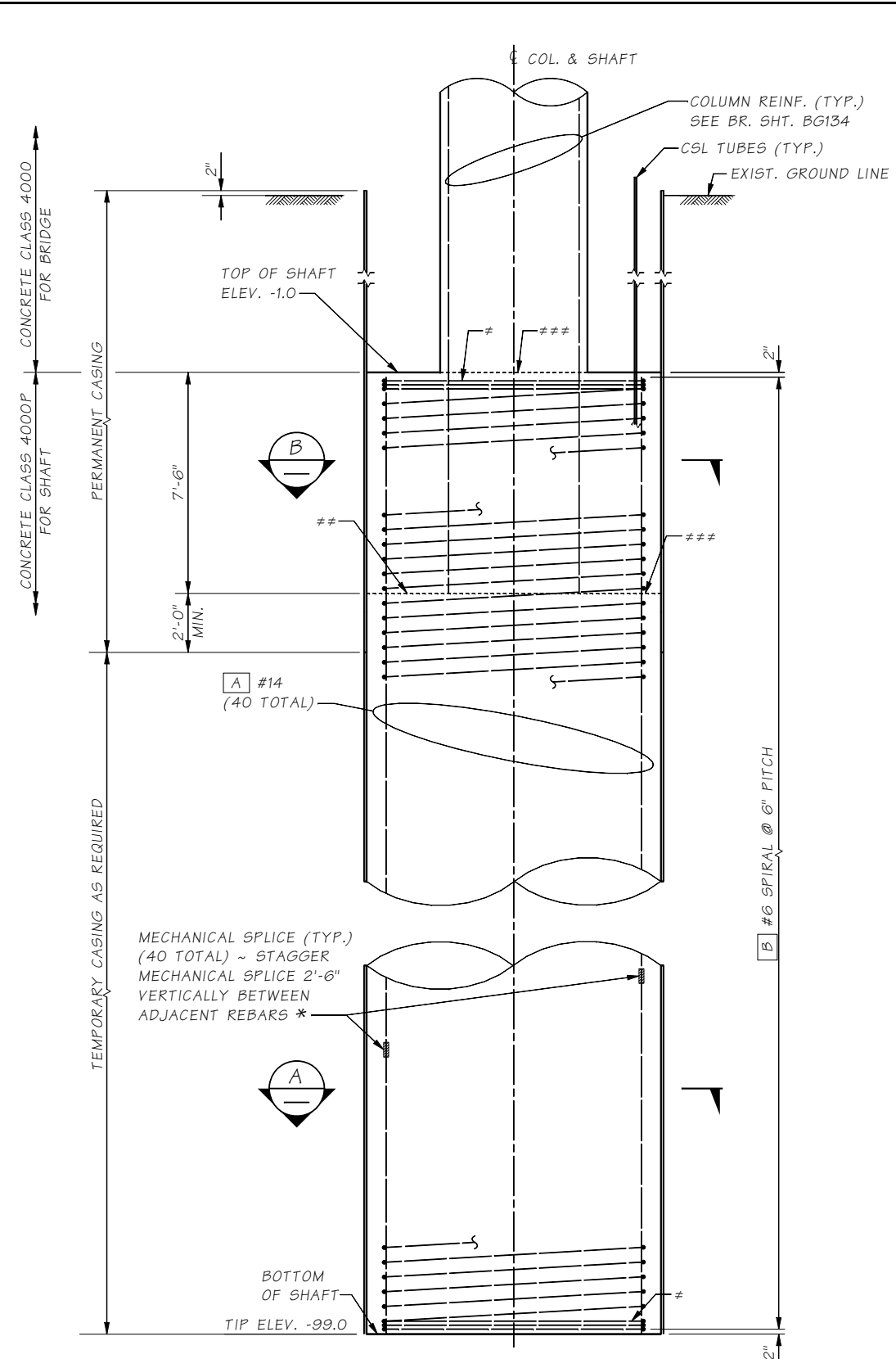

ELEVATION

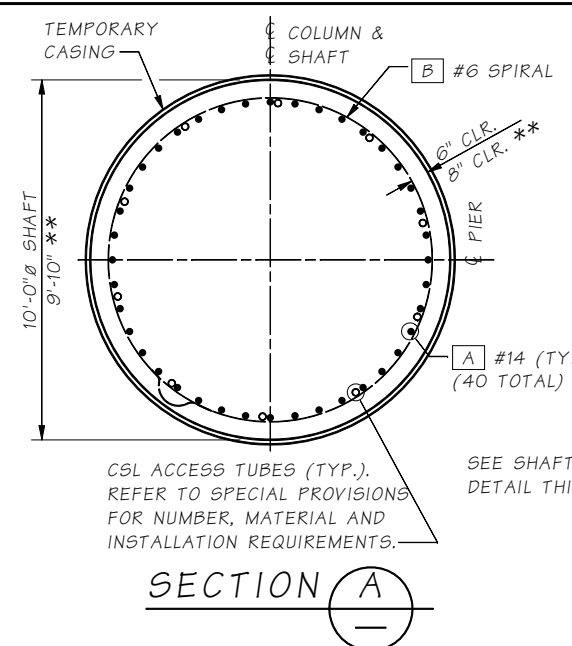

SECTION A

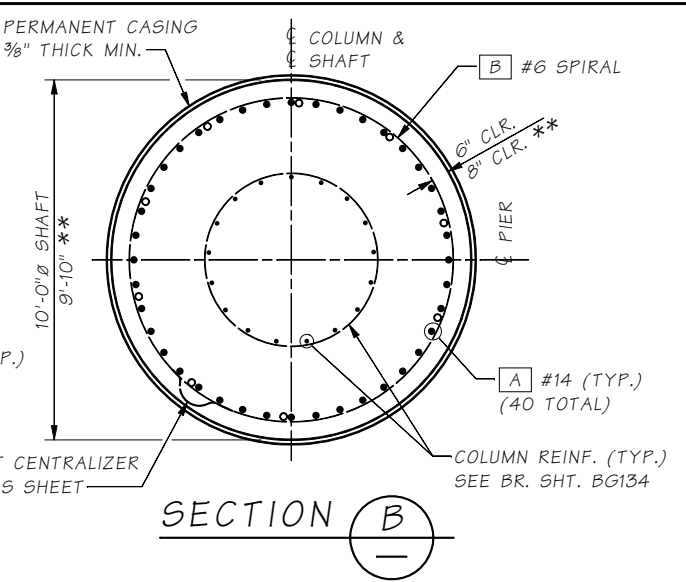

SECTION B

SHAFT BAR LIST
ALL REINFORCING SHALL BE ASTM A 706
QUANTITIES ARE PER SHAFT

MARK	SIZE	NO.	LENGTH	BEND TYPE	WT. (lbs.)
A	#14	40	97'-9"	STR.	29,885
B	#6	1	5846'-3"	67	8,330
TOTAL					38,240

(a) ~ DETERMINED FROM PLANS
WEIGHT INCLUDES SPLICES

SPIRAL (BEND TYPE 67)

- * MECHANICAL SPLICE SHALL MEET THE REQUIREMENTS OF STD. SPEC. 6-02.3(24)F
- ** SHAFT CONSTRUCTED WITH THE OSCILLATOR METHOD. THE CONTRACTOR SHALL REVISE THE SHAFT BARLIST IF THE OSCILLATOR METHOD IS CHOSEN FOR SHAFT CONSTRUCTION
- # SEE SPIRAL TERMINATION DETAIL THIS SHEET
- ** REMOVE SEDIMENT LAITENCE & WEAK CONCRETE TO SOUND CONCRETE PRIOR TO SETTING COLUMN REINFORCEMENT
- *** CONST. JOINT WITH ROUGHENED SURFACE

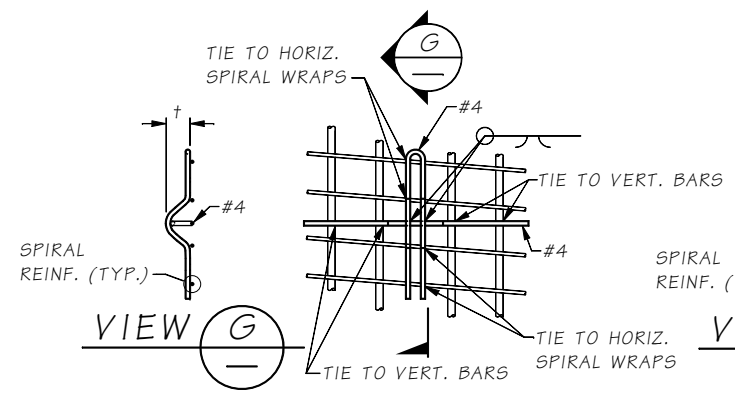

CENTRALIZER DETAIL

EPOXY COAT CENTRALIZER OR PAINT WITH INORGANIC ZINC AFTER FABRICATION (OPTION 1)

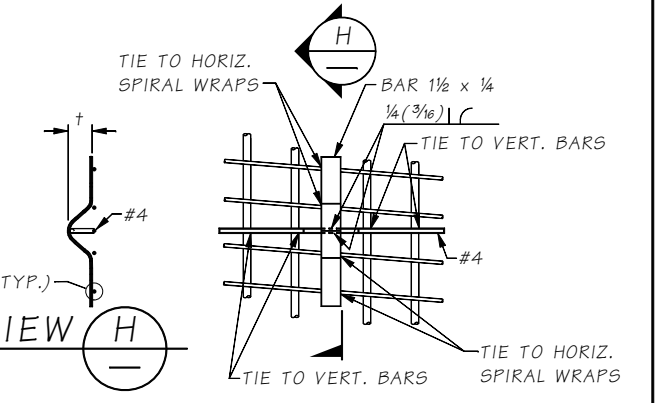

CENTRALIZER DETAIL

EPOXY COAT CENTRALIZER OR PAINT WITH INORGANIC ZINC AFTER FABRICATION (OPTION 2)

- NOTES:**
- EACH LEG SHOULD BE TIED TO TWO VERTICAL BARS OR TWO SPIRALS.
 - SEE SPECIAL PROVISIONS FOR SPACING REQUIREMENTS.
 - + CONCRETE COVER MINUS 1/2"

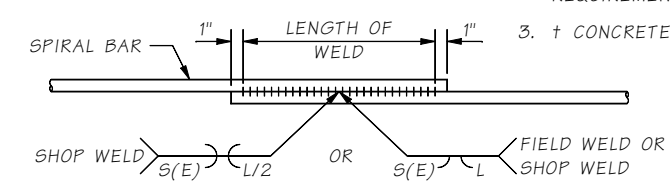

WELDED LAP SPLICE DETAIL

WELDING SHALL MEET THE REQUIREMENTS OF STD. SPEC. 6-02.3(24)E FOR WELD DIMENSIONS SEE TABLE BELOW.

SPIRAL INFORMATION			
DEFORMED BAR ASTM A 706	WELD DEMENSIONS		
	S	E	LENGTH (L)
#6 SPIRAL	3/8"	3/16"	6"

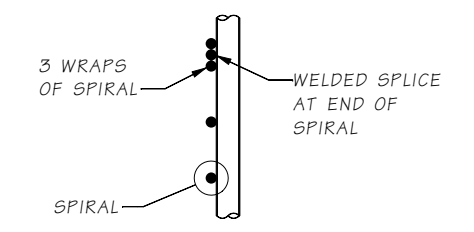

SPIRAL TERMINATION DETAIL

Bridge Design Engr. Khaleghi, B	M:\Y-Team\AWV SOUTH INTERCHANGE\window files\Pier 6C Shaft Dtl's.WND	REGION NO.	STATE	FED. AID PROJ. NO.	SHEET NO.	TOTAL SHEETS
Supervisor Moore, TM		10	WASH.			
Designed By Talukdar, M	10/08					
Checked By Mizumori, A	08/09					
Detailed By Evans, A	10/08					
Bridge Projects Engr.						
Prelim. Plan By						
Architect/Specialist	DATE	REVISION	BY	APPD		



BRIDGE AND STRUCTURES OFFICE



SR 99
ALASKAN WAY VIADUCT - REPLACEMENT
S HOLGATE ST TO S KING ST - PHASE 2
BRIDGE NO. 99/540 NB & SB

PIER 6C SHAFT DETAILS

BRIDGE SHEET NO. **BG133**
SHEET 979 OF 1475 SHEETS

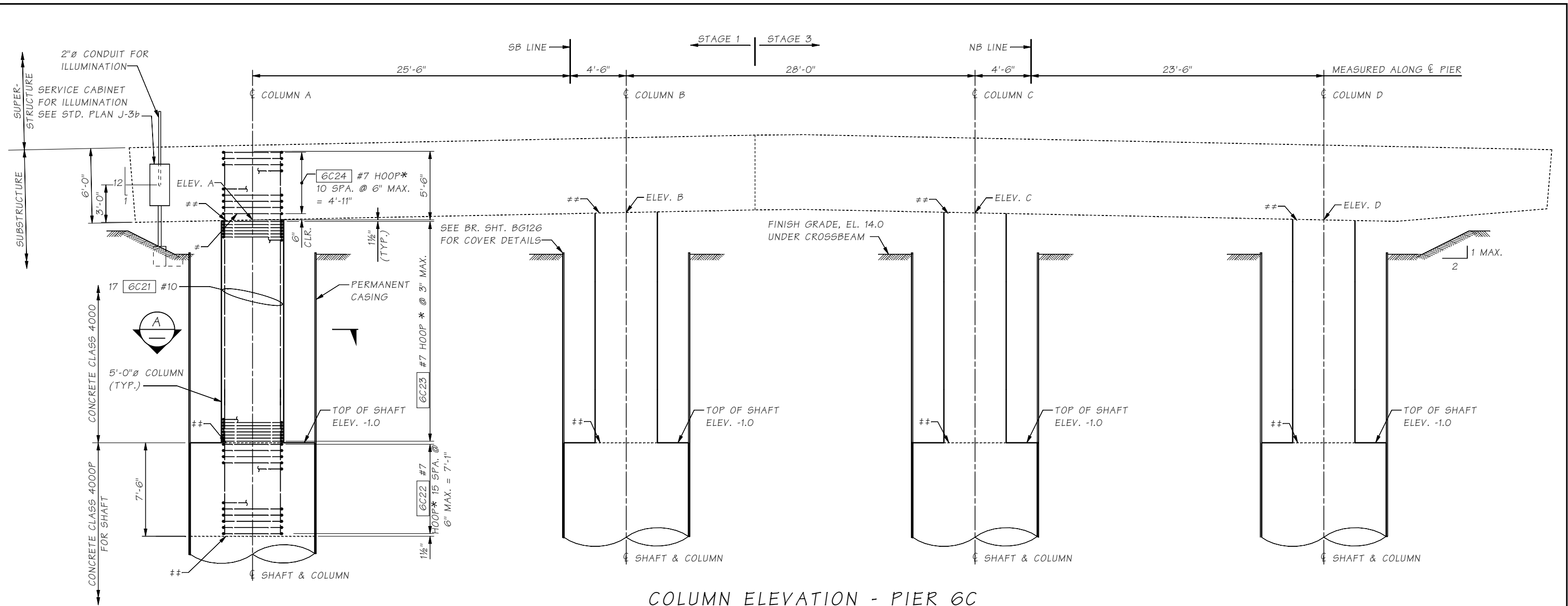

COLUMN ELEVATION - PIER 6C

TABLE OF ELEVATIONS	
TOP OF COLUMN	ELEVATION
ELEV. A	16.76
ELEV. B	17.36
ELEV. C	17.32
ELEV. D	16.76

* HOOP WELD SHALL BE DIRECT BUTT-WELDED AND CONFORM TO THE CURRENT EDITION OF STRUCTURAL WELDING CODE - REINFORCING STEEL OF AWS(D1.4) AND MEET THE REQUIREMENTS OF STD. SPEC. 6-02.3(24)E RESISTANCE BUTT WELDED SPLICE MAY BE SUBSTITUTED AT THE CONTRACTOR'S OPTION. SEE SPECIAL PROVISIONS.

CONSTRUCTION JOINT W/ ROUGHENED SURFACE

NOTE:
COLUMN DETAILS & REINFORCING
TYPICAL FOR ALL COLUMNS.

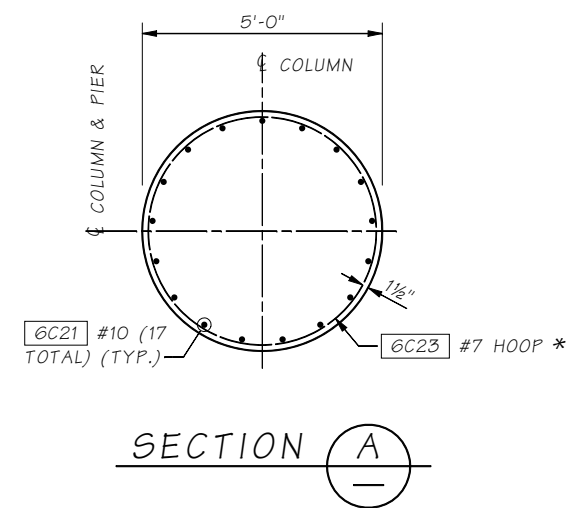
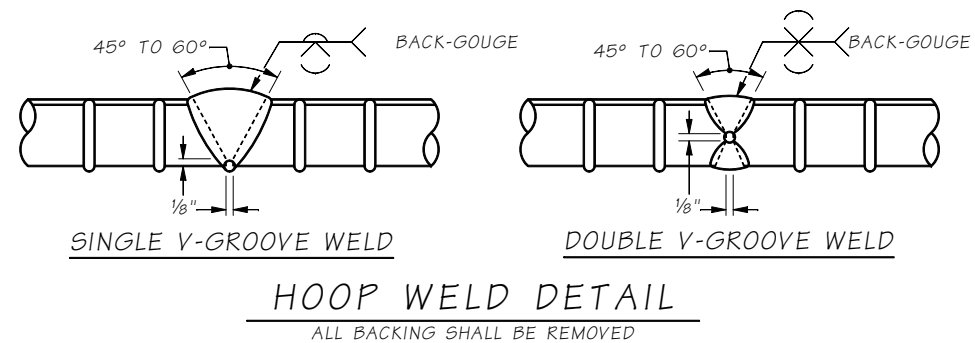

SR 99 FILE NO. SHEET BG134

Bridge Design Engr.	Khaleghi, B	M:\Y-Team\AWV SOUTH INTERCHANGE\window files\PIER 6C COLUMN.WND			
Supervisor	Moore, TM	REGION NO.	STATE	FED. AID PROJ. NO.	SHEET NO.
Designed By	Mizumori, A	10	WASH.		TOTAL SHEETS
Checked By	Talukdar, M	JOB NUMBER 09A803			
Detailed By	Evans, A				
Bridge Projects Engr.					
Prelim. Plan By					
Architect/Specialist		DATE	REVISION	BY	APPD



BRIDGE AND STRUCTURES OFFICE



SR 99
ALASKAN WAY VIADUCT - REPLACEMENT
S HOLGATE ST TO S KING ST - PHASE 2
BRIDGE NO. 99/540 NB & SB
PIER 6C COLUMN DETAILS

BRIDGE SHEET NO. BG134
SHEET 980 OF 1475 SHEETS

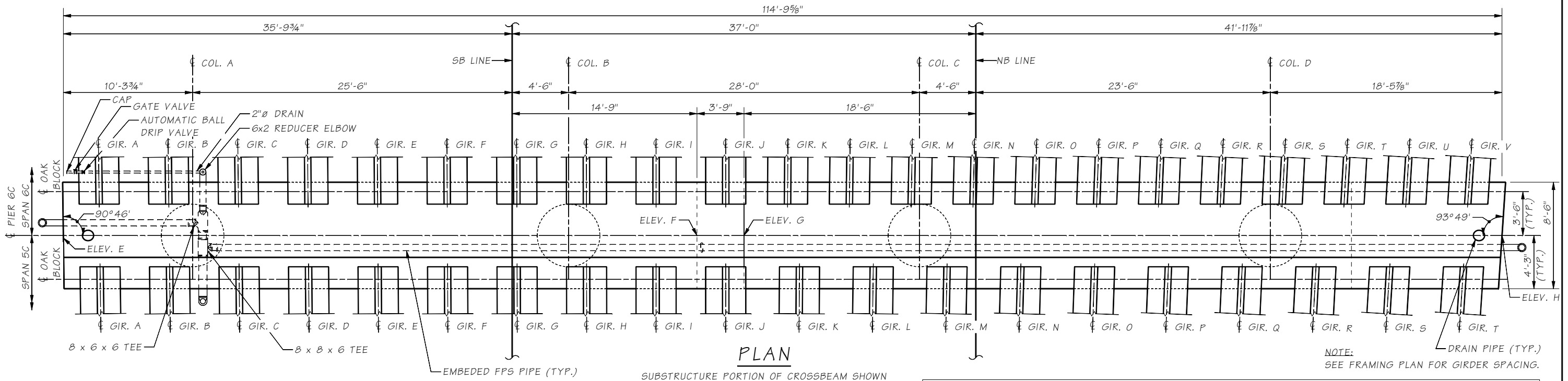
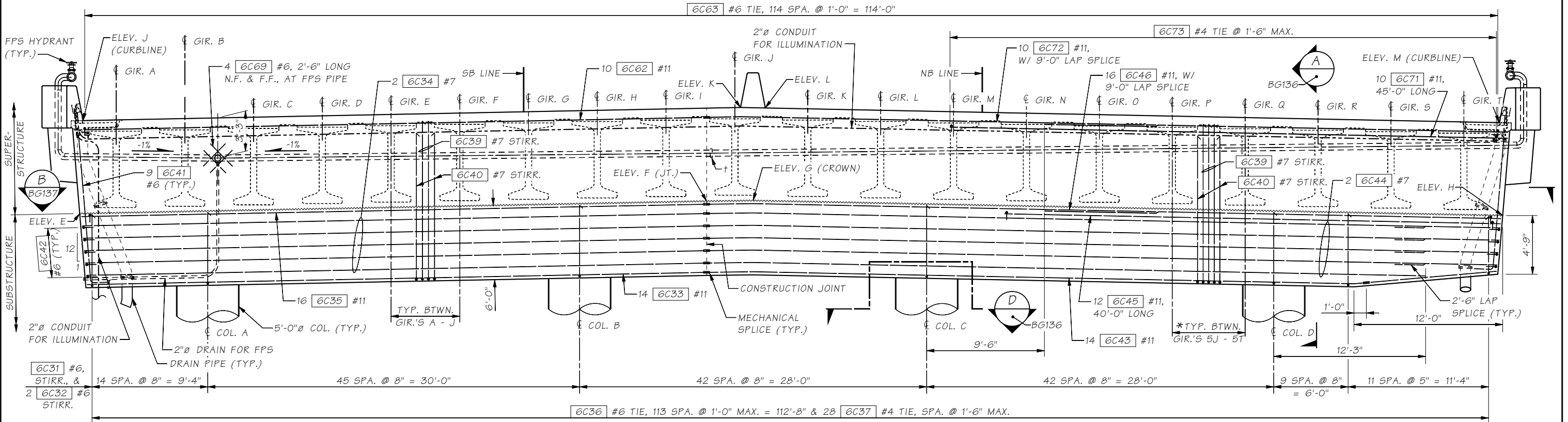

TABLE OF ELEVATIONS (ALONG & PIER)

LOCATION	E	F	G	H	J	K	L	M
ELEVATION	22.55	23.55	23.60	22.39	30.06	31.12	31.08	29.89



ELEVATION

SEE BR. SHEET BG138 FOR CROSSBEAM END DETAILS

* SIMILAR BTWN. GIR.'S 6J - 6V

N.F. = NEAR FACE
F.F. = FAR FACE

SR 99 FILE NO. SHEET BG135

Bridge Design Engr.	Khaleghi, B	M:\Y-Team\AW SOUTH INTERCHANGE\window files\Pier 6C X-Beam Plan-Elev.WND			
Supervisor	Moore, TM	REGION NO.	STATE	FED. AID PROJ. NO.	SHEET NO.
Designed By	Mizumori, A 05/09	10	WASH.		
Checked By	Rodda, NT 09/09	JOB NUMBER 09A803			
Detailed By	Evans, A 05/09				
Bridge Projects Engr.		DATE	REVISION	BY	APPD
Prelim. Plan By					
Architect/Specialist					

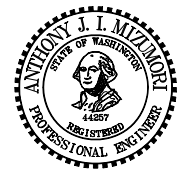

BRIDGE AND STRUCTURES OFFICE

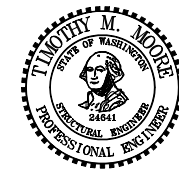

SR 99
ALASKAN WAY VIADUCT - REPLACEMENT
S HOLGATE ST TO S KING ST - PHASE 2
BRIDGE NO. 99/540 NB & SB

PIER 6C CROSSBEAM
PLAN AND ELEVATION

BRIDGE SHEET NO. **BG135**
SHEET 981 OF 1475 SHEETS

TABLE OF ELEVATIONS @ TOP OF OAK BLOCK

SPAN 5C GIRDERS (SB)	5A	5B	5C	5D	5E	5F	5G	5H	5I	5J	6U	6V
	23.24	23.35	23.46	23.57	23.69	23.80	23.91	24.02	24.13	24.24		
SPAN 5C GIRDERS (NB)	5K	5L	5M	5N	5O	5P	5Q	5R	5S	5T	6U	6V
	24.14	24.03	23.91	23.79	23.67	23.56	23.44	23.32	23.20	23.09		
SPAN 6C GIRDERS (SB)	6A	6B	6C	6D	6E	6F	6G	6H	6I	6J	6U	6V
	22.81	22.92	23.03	23.14	23.25	23.36	23.47	23.58	23.70	23.81		
SPAN 6C GIRDERS (NB)	6K	6L	6M	6N	6O	6P	6Q	6R	6S	6T	6U	6V
	23.73	23.63	23.53	23.43	23.33	23.24	23.14	23.04	22.94	22.84		

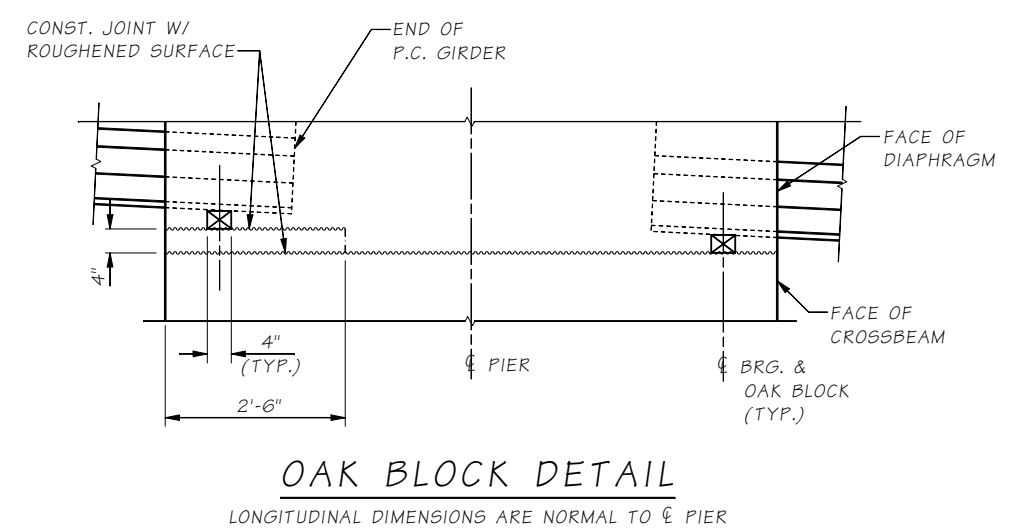
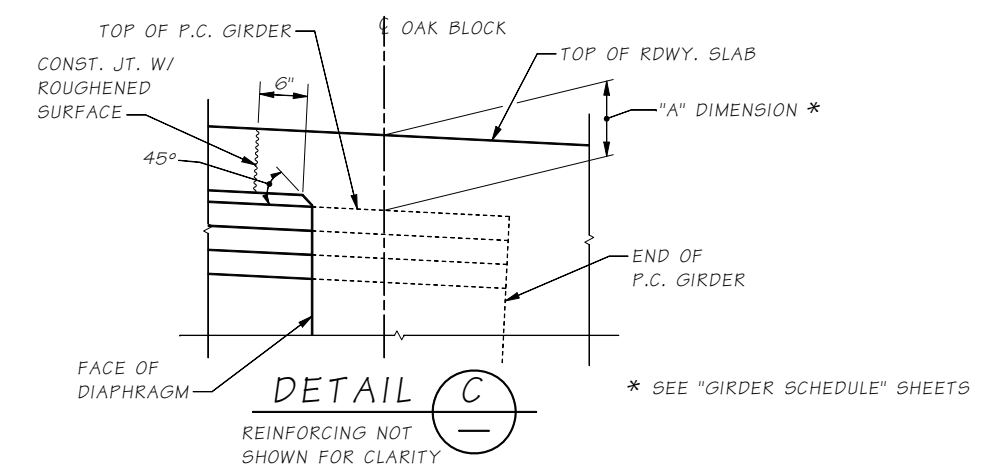
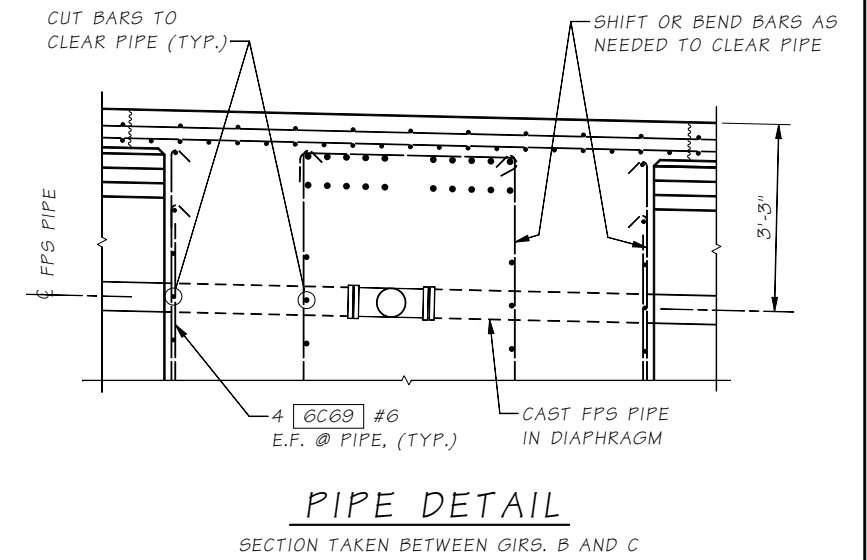
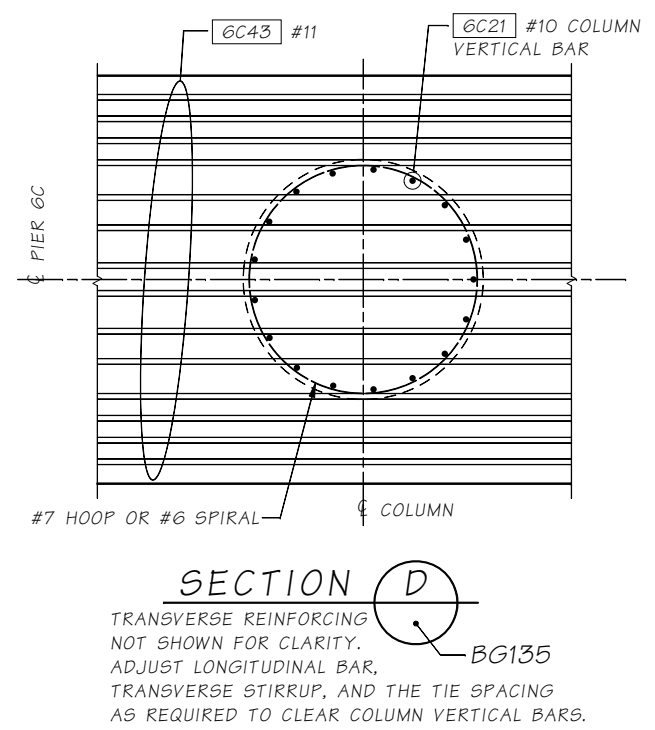
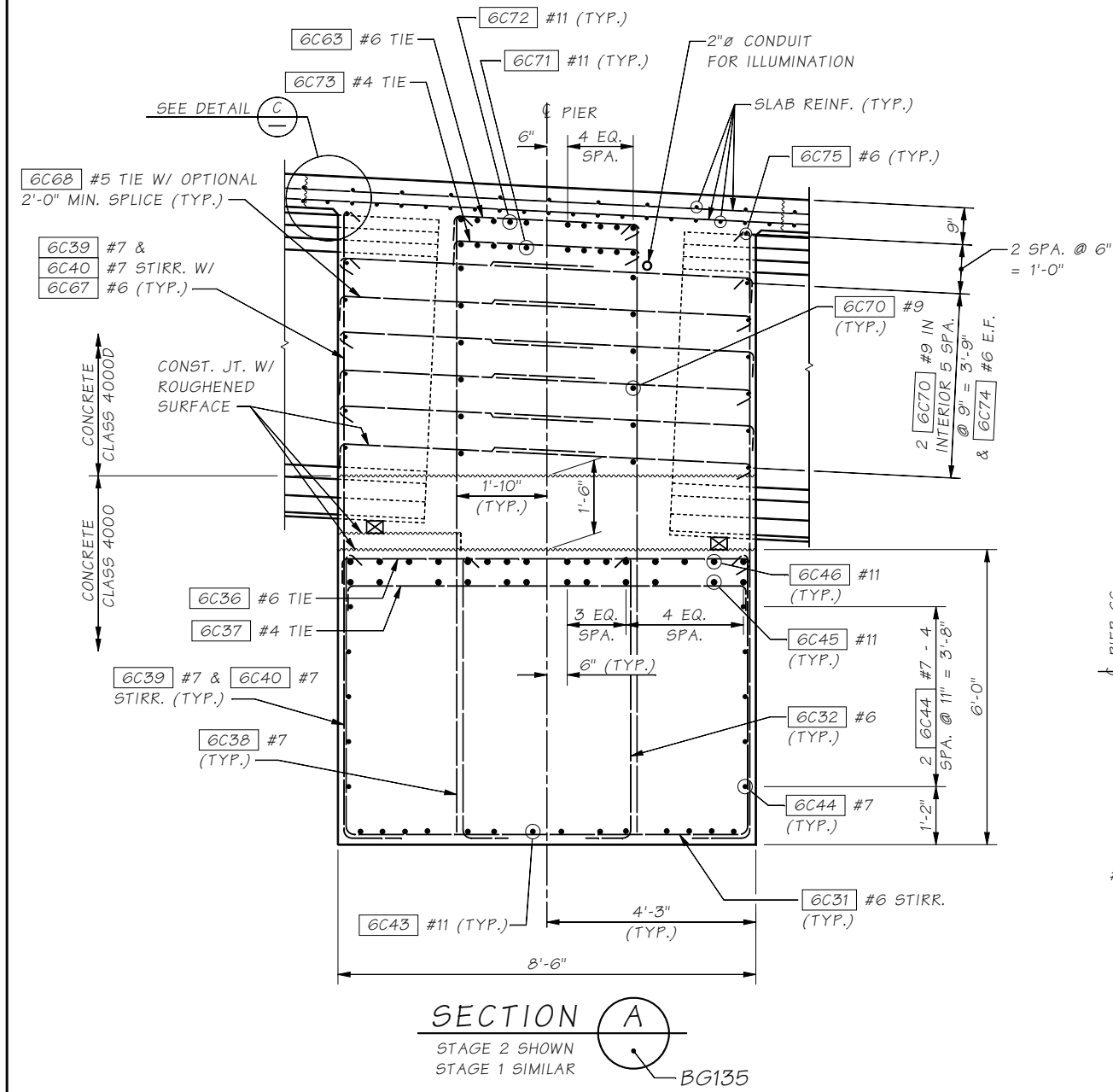

SR 99 FILE NO. SHEET BG136

Bridge Design Engr.	Khaleghi, B	M:\Y-Team\AWV SOUTH INTERCHANGE\window files\PIER 6C CROSSBEAM I.WND			
Supervisor	Moore, TM	REGION NO.	STATE	FED. AID PROJ. NO.	SHEET NO.
Designed By	Mizumori, A 10/08	10	WASH.		
Checked By	Rodda, NT 09/09	JOB NUMBER			
Detailed By	Evans, A 10/08	09A803			
Bridge Projects Engr.		DATE	REVISION	BY	APPD
Prelim. Plan By					
Architect/Specialist					



BRIDGE AND STRUCTURES OFFICE



SR 99
ALASKAN WAY VIADUCT - REPLACEMENT
S HOLGATE ST TO S KING ST - PHASE 2
BRIDGE NO. 99/540 NB & SB
PIER 6C CROSSBEAM DETAILS 1 OF 3

BRIDGE SHEET NO. BG136
SHEET 982 OF 1475 SHEETS

SR 99 FILE NO. SHEET BG137

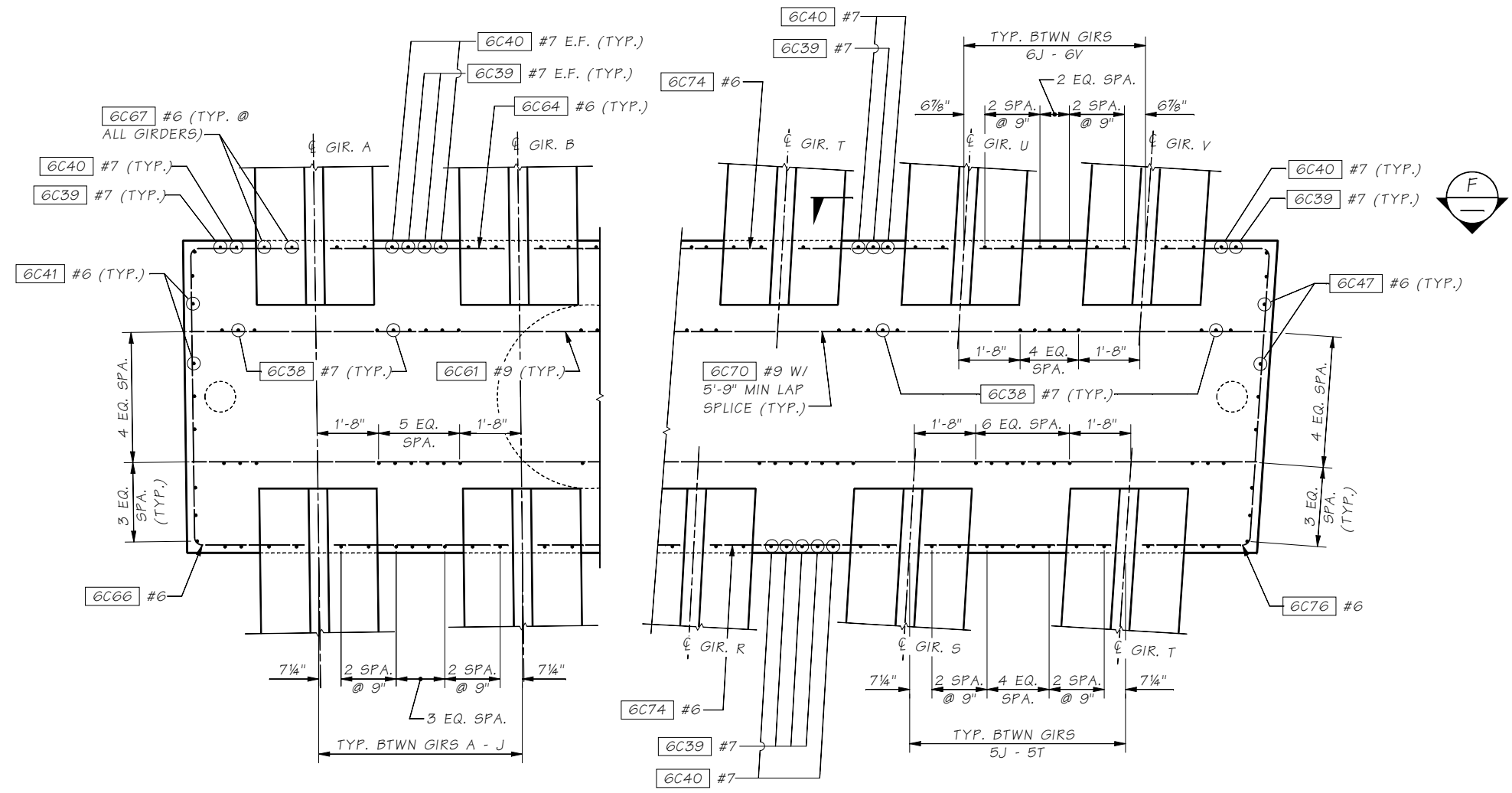

SECTION B
BG135

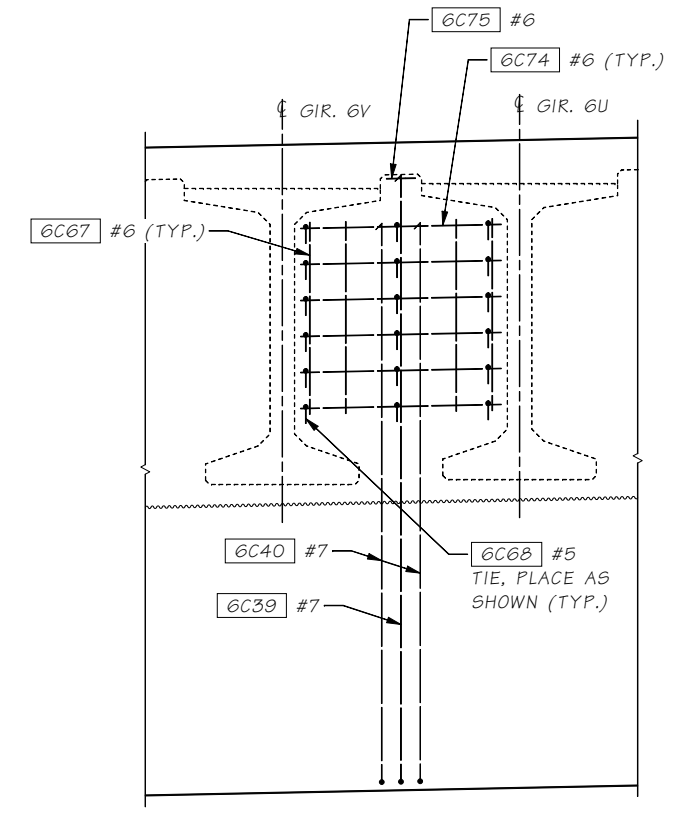

SECTION F
TYPICAL REINF. BETWEEN GIRDERS 6J & 6V
LOOKING BACK ON STATION

Bridge Design Engr.	Khaleghi, B	M:\Y-Team\AWV SOUTH INTERCHANGE\window files\PIER 6C CROSSBEAM 2.WND			
Supervisor	Moore, TM	REGION NO.	STATE	FED. AID PROJ. NO.	SHEET NO.
Designed By	Mizumori, A	10	WASH.		TOTAL SHEETS
Checked By	Rodda, NT	JOB NUMBER 09A803			
Detailed By	Evans, A				
Bridge Projects Engr.					
Prelim. Plan By					
Architect/Specialist		DATE	REVISION	BY	APPD

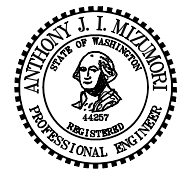

BRIDGE AND STRUCTURES OFFICE

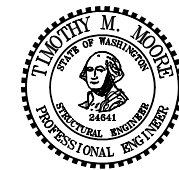

SR 99
ALASKAN WAY VIADUCT - REPLACEMENT
S HOLGATE ST TO S KING ST - PHASE 2
BRIDGE NO. 99/540 NB & SB
PIER 6C CROSSBEAM DETAILS 2 OF 3

BRIDGE SHEET NO. BG137
SHEET 983 OF 1475 SHEETS

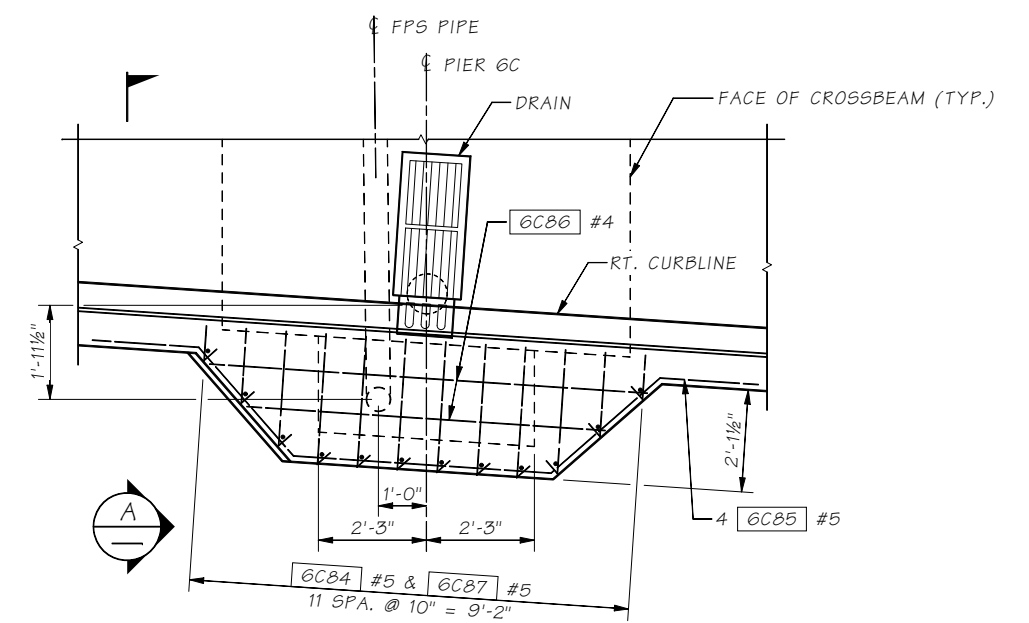
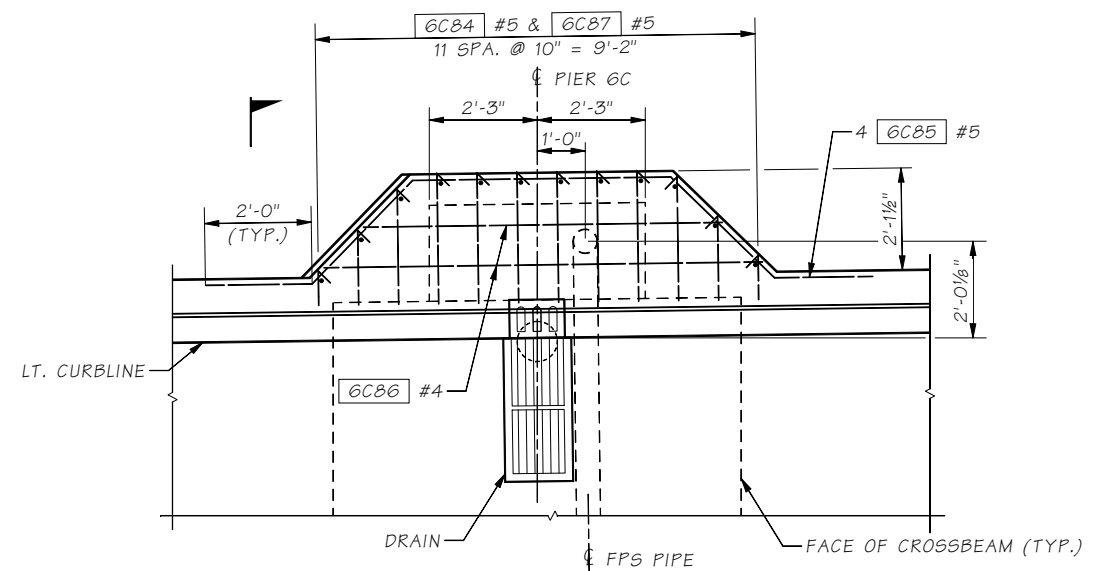

PLAN
LT. CURBLINE

PLAN
RT. CURBLINE

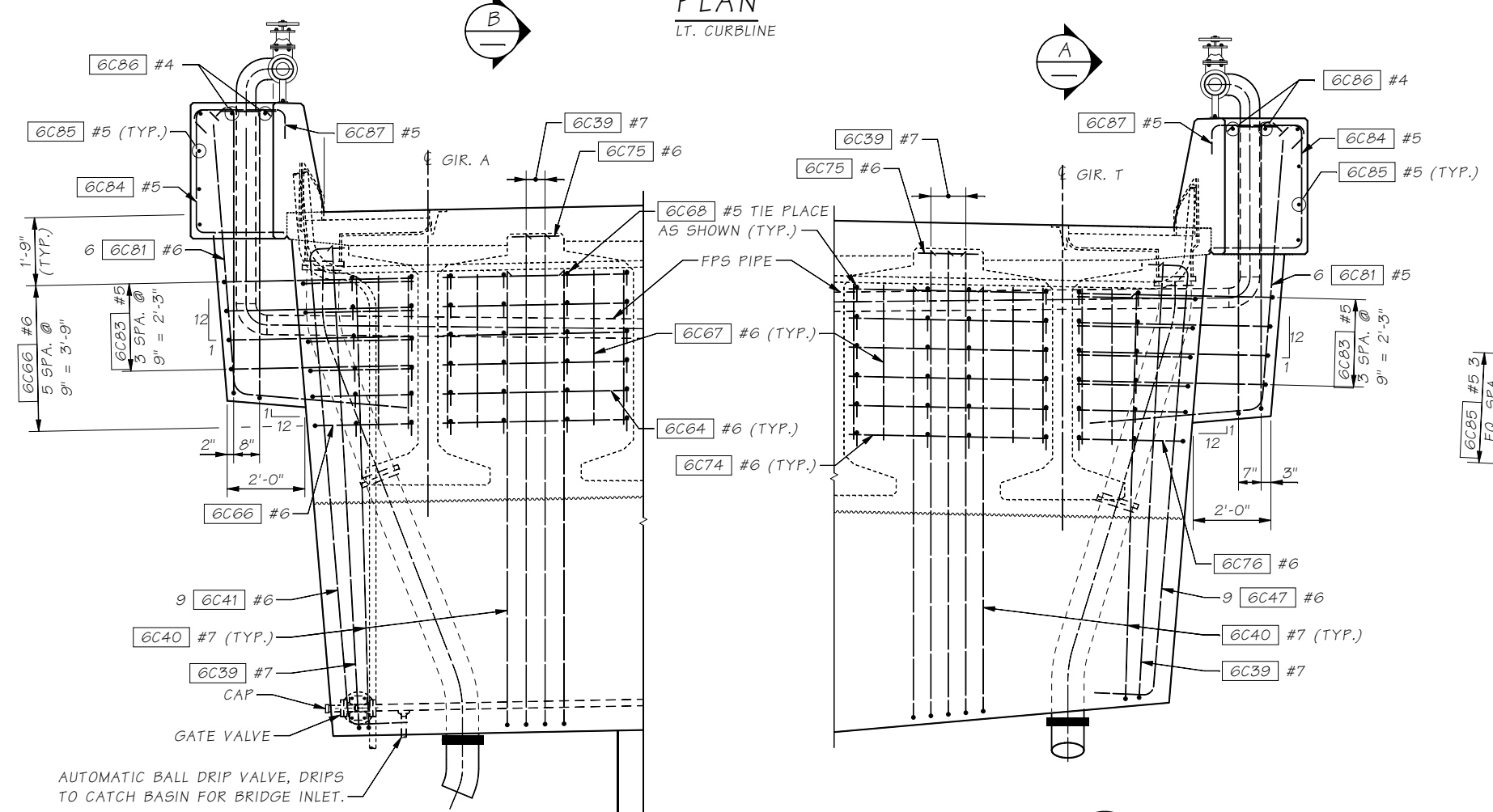

SECTION B
TRAFFIC BARRIER REINF.
NOT SHOWN FOR CLARITY

SECTION A
TRAFFIC BARRIER REINF.
NOT SHOWN FOR CLARITY

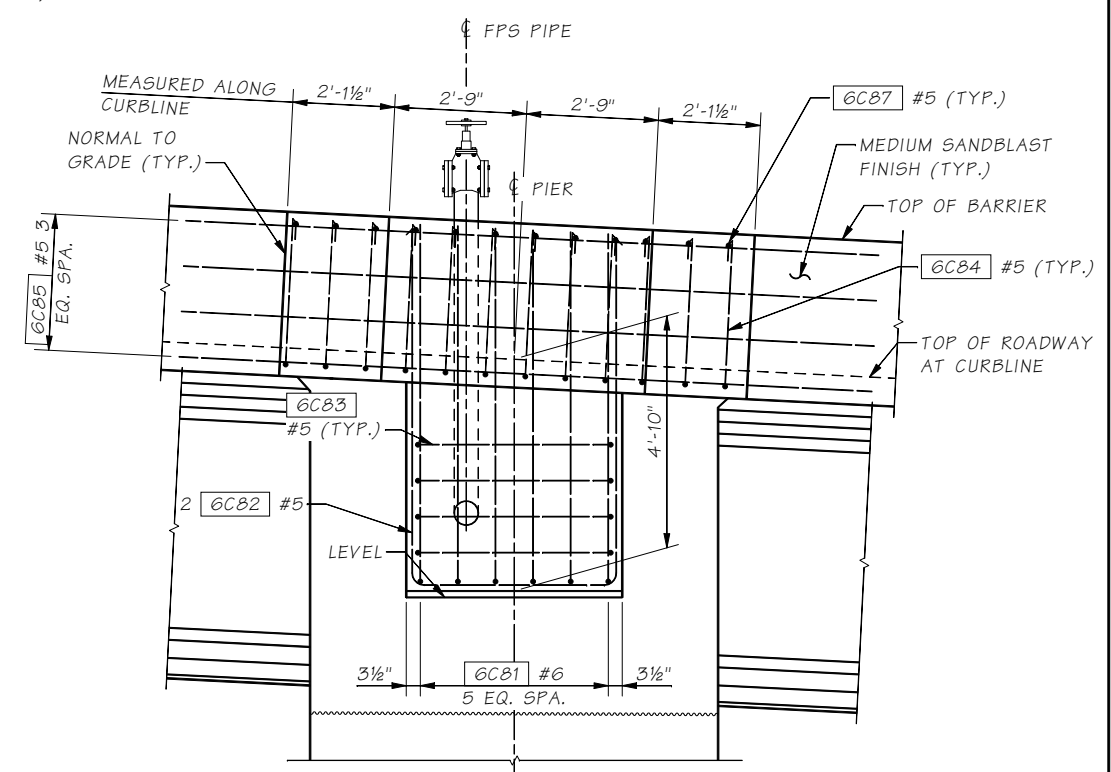

ELEVATION
RT. CURBLINE SHOWN,
LT. CURBLINE SIMILAR

SR 99 FILE NO. SHEET BG138

Bridge Design Engr.	Khaleghi, B	M:\Y-Team\AWV SOUTH INTERCHANGE\window files\PIER 6C CROSSBEAM 3.WND			
Supervisor	Moore, TM	REGION NO.	STATE	FED. AID PROJ. NO.	SHEET TOTAL
Designed By	Mizumori, A 08/09	10	WASH.		
Checked By	Rodda, NT 09/09	JOB NUMBER 09A803			
Detailed By	Evans, A 08/09				
Bridge Projects Engr.		DATE	REVISION	BY	APPD
Prelim. Plan By					
Architect/Specialist					



BRIDGE AND STRUCTURES OFFICE

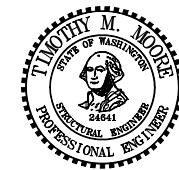

SR 99
ALASKAN WAY VIADUCT - REPLACEMENT
S HOLGATE ST TO S KING ST - PHASE 2
BRIDGE NO. 99/540 NB & SB
PIER 6C CROSSBEAM DETAILS 3 OF 3

BRIDGE SHEET NO. BG138
SHEET 984 OF 1475 SHEETS

SR 99 FILE NO. SHEET BG139

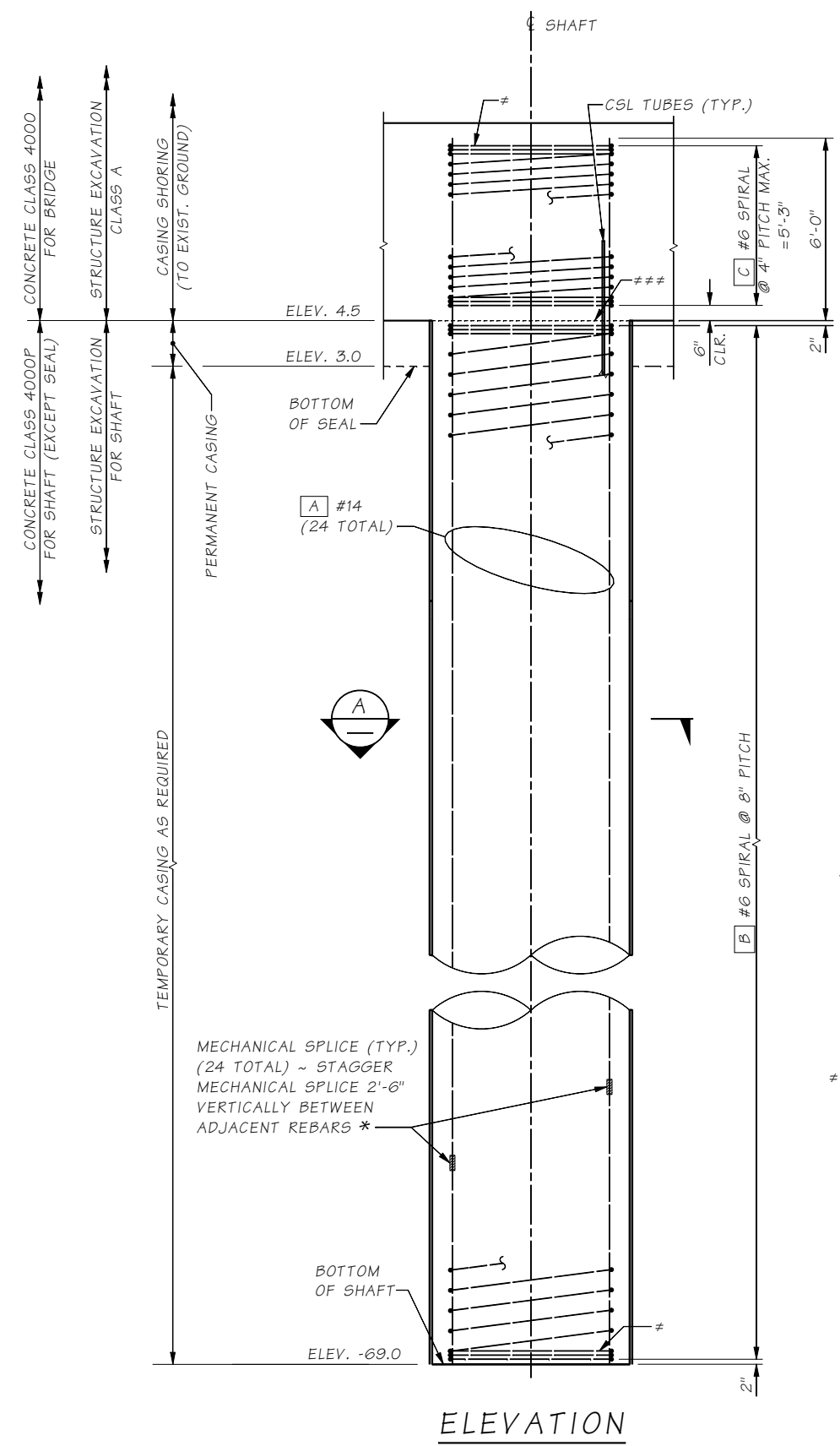

ELEVATION

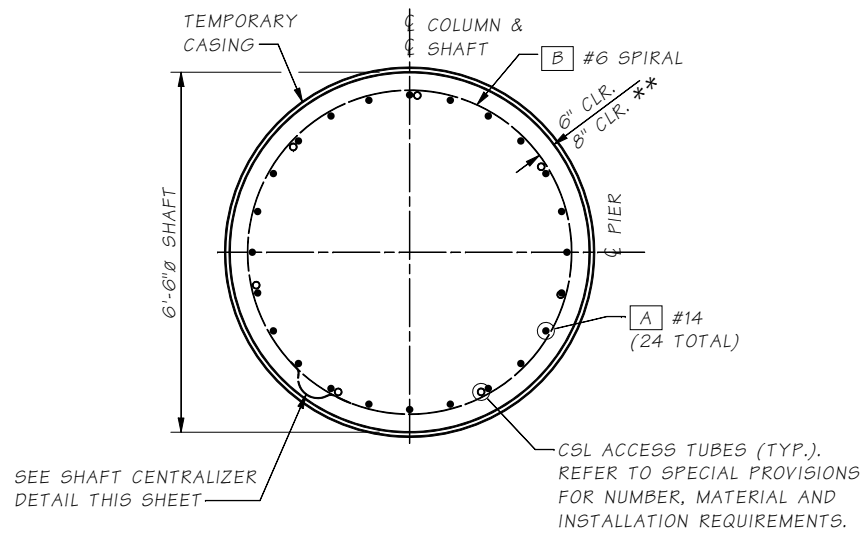

SECTION A

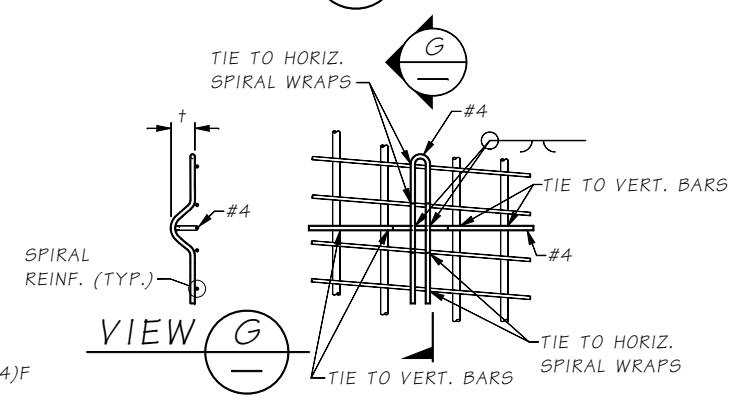

CENTRALIZER DETAIL

EPOXY COAT CENTRALIZER OR PAINT WITH INORGANIC ZINC AFTER FABRICATION (OPTION 1)

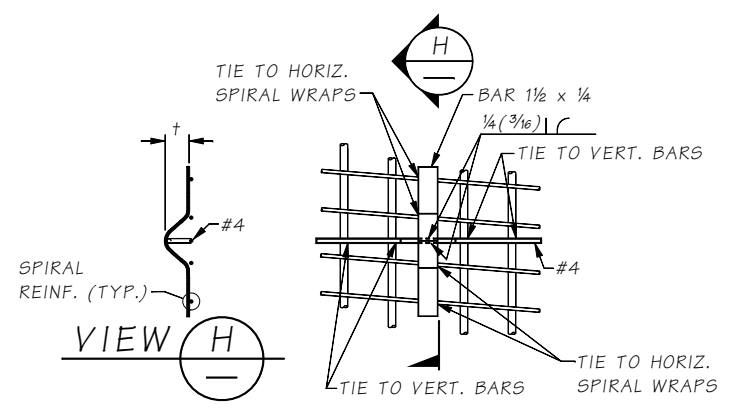

CENTRALIZER DETAIL

EPOXY COAT CENTRALIZER OR PAINT WITH INORGANIC ZINC AFTER FABRICATION (OPTION 2)

NOTES:

1. EACH LEG SHOULD BE TIED TO TWO VERTICAL BARS OR TWO SPIRALS.
2. SEE SPECIAL PROVISIONS FOR SPACING REQUIREMENTS.
3. + CONCRETE COVER MINUS 1/2"

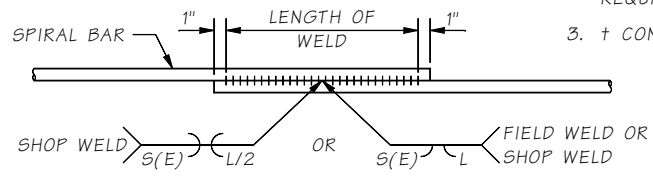

WELDED LAP SPLICE DETAIL

WELDING SHALL MEET THE REQUIREMENTS OF STD. SPEC. 6-02.3(24)E FOR WELD DIMENSIONS SEE TABLE BELOW.

SPIRAL INFORMATION			
DEFORMED BAR ASTM A 706	WELD DIMENSIONS		
	S	E	LENGTH (L)
#6 SPIRAL	3/8"	3/16"	6"

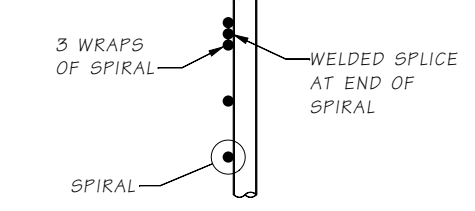

SPIRAL TERMINATION DETAIL

SHAFT BAR LIST

ALL REINFORCING SHALL BE ASTM A 706 QUANTITIES ARE PER SHAFT

MARK	SIZE	NO.	LENGTH	BEND TYPE	WT. (lbs.)
A	#14	24	79'-4 1/2"	STR.	14,573
B	#6	1	1897'-0"	67	2,849
C	#6	1	272'-1"	67	409
TOTAL					17,422

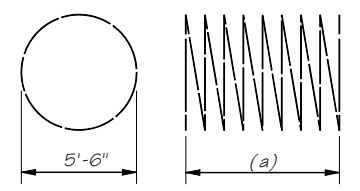

(a) ~ DETERMINED FROM PLANS WEIGHT INCLUDES SPLICES

SPIRAL (BEND TYPE 67)

Bridge Design Engr. Khaleghi, B	M:\Y-Team\AWV SOUTH INTERCHANGE\window files\PIER 7C SHAFT DETAILS.WND	REGION NO.	STATE	FED. AID PROJ. NO.	SHEET NO.	TOTAL SHEETS
Supervisor Moore, TM		10	WASH.			
Designed By Talukdar, M	10/08	JOB NUMBER 09A803				
Checked By Rodda, NT	09/09					
Detailed By Evans, A	10/08					
Bridge Projects Engr.						
Prelim. Plan By						
Architect/Specialist	DATE	REVISION	BY	APPD		



BRIDGE AND STRUCTURES OFFICE

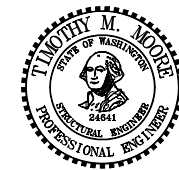

SR 99
ALASKAN WAY VIADUCT - REPLACEMENT
S HOLGATE ST TO S KING ST - PHASE 2
BRIDGE NO. 99/540 NB & SB

PIER 7C SHAFT DETAILS

BRIDGE SHEET NO. BG139
SHEET 985 OF 1475 SHEETS

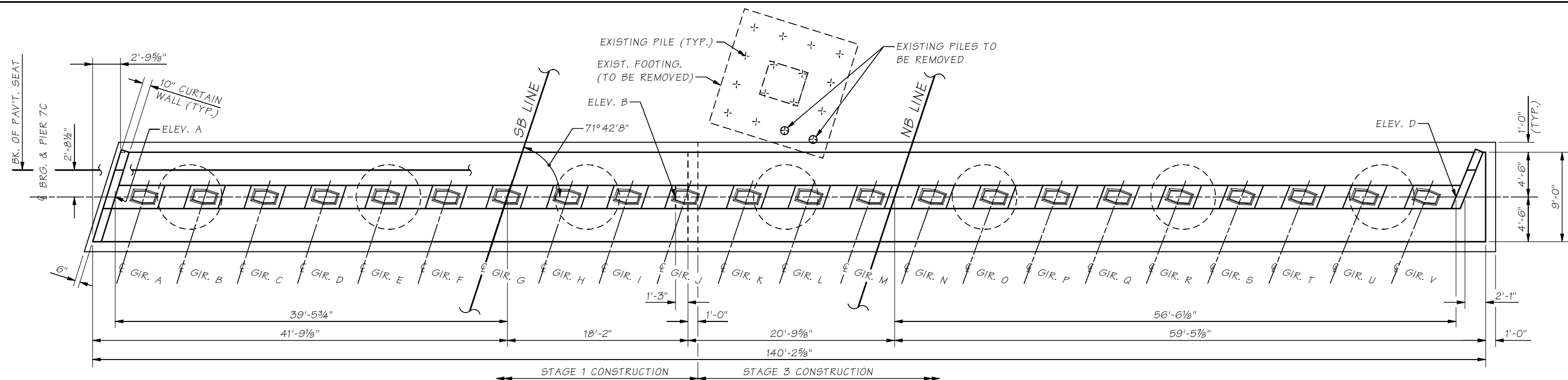

PLAN

NOTE:
SEE FRAMING PLAN FOR GIRDER SPACING.

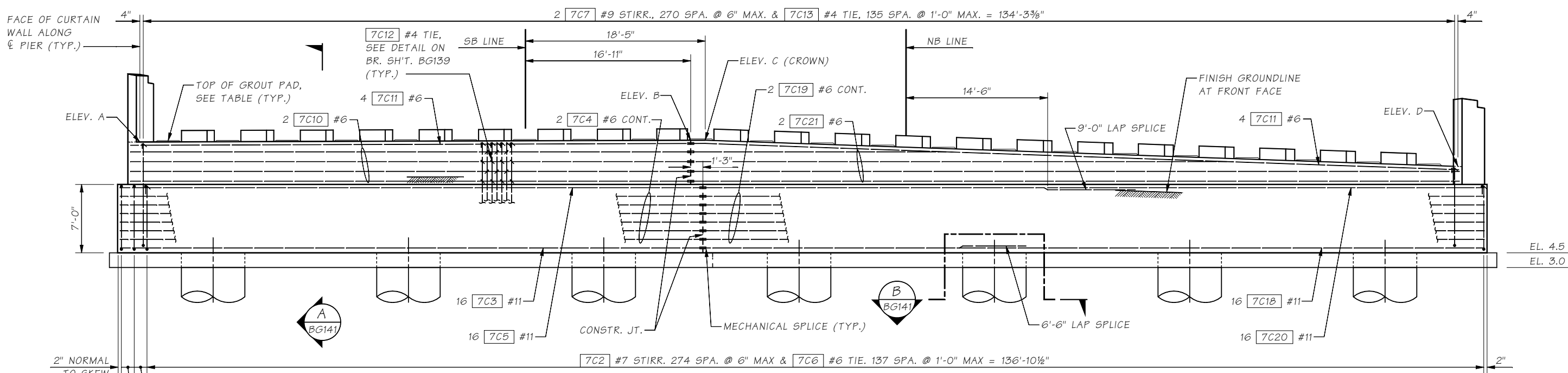

ELEVATION

FOR CURTAIN WALL DETAILS, SEE BR. SH'T. BG142 & BG143.

TABLE OF ELEVATIONS (ALONG PIER)

LOCATION	ELEVATION	LOCATION	ELEVATION
A	15.84	C	16.03
B	16.01	D	13.35

TABLE OF ELEVATIONS @ TOP OF GROUT PADS

GIRDER	6A	6B	6C	6D	6E	6F	6G	6H	6I	6J	6K	6L	6M	6N	6O	6P	6Q	6R	6S	6T	6U	6V
ELEV.	15.97	15.99	16.01	16.03	16.05	16.07	16.09	16.11	16.13	16.15	15.95	15.74	15.52	15.30	15.09	14.87	14.66	14.44	14.23	14.01	13.80	13.58

SR 99 FILE NO. SHEET BG140

Bridge Design Engr.	Khaleghi, B	M:\Y-Team\AWV SOUTH INTERCHANGE\window files\Pier 7C Plan-Elev.WND
Supervisor	Moore, TM	
Designed By	Mizumori, A	06/09
Checked By	Rodda, NT	09/09
Detailed By	Evans, A	06/09
Bridge Projects Engr.		
Prelim. Plan By		
Architect/Specialist		
DATE	REVISION	BY APPD

REGION NO.	STATE	FED. AID PROJ. NO.	SHEET NO.	TOTAL SHEETS
10	WASH.			
JOB NUMBER				
09A803				



BRIDGE AND STRUCTURES OFFICE

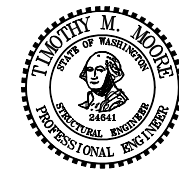

SR 99
ALASKAN WAY VIADUCT - REPLACEMENT
S HOLGATE ST TO S KING ST - PHASE 2
BRIDGE NO. 99/540 NB & SB

PIER 7C PLAN AND ELEVATION

BRIDGE SHEET NO. BG140
SHEET 986 OF 1475 SHEETS

SUGGESTED CONSTRUCTION SEQUENCE

1. INSTALL SHORING COFFERDAM FOR PIER.
2. EXCAVATE WITHIN COFFERDAM TO BOTTOM OF SEAL ELEVATION.
3. CONSTRUCT SHAFTS USING TEMPORARY CASING AND CASING SHORING.
4. CONSTRUCT SEAL
5. DEWATER COFFERDAM.
6. REMOVE CASING SHORING, PERMANENT CASING TO REMAIN.
7. CONSTRUCT PIER
8. BACKFILL
9. REMOVE SHORING COFFERDAM.

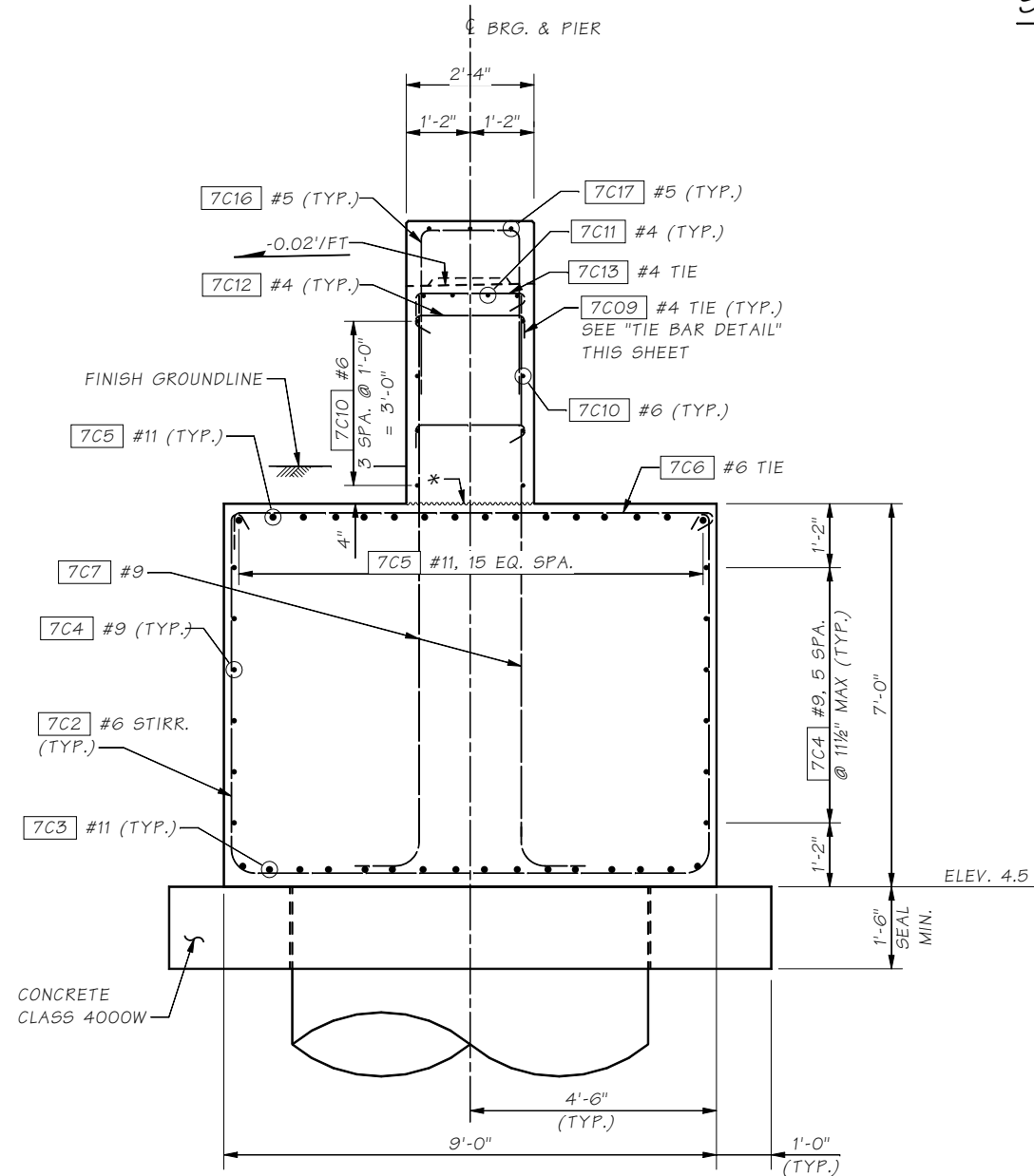

SECTION A
STAGE 1 SHOWN
STAGE 3 SIMILAR
BG140

* CONSTRUCTION JOINT
WITH ROUGHENED SURFACE

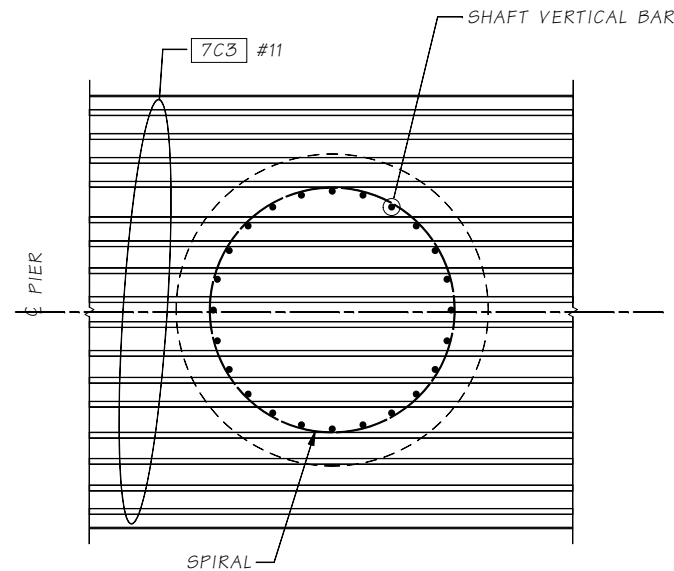

SECTION B
TRANSVERSE REINFORCING
NOT SHOWN FOR CLARITY.
ADJUST LONGITUDINAL BAR, TRANSVERSE
STIRRUP, AND TIE SPACING AS REQUIRED
TO CLEAR SHAFT VERTICAL BARS.
BG140

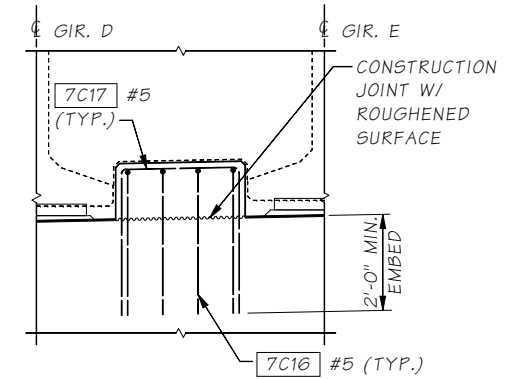

SECTION F

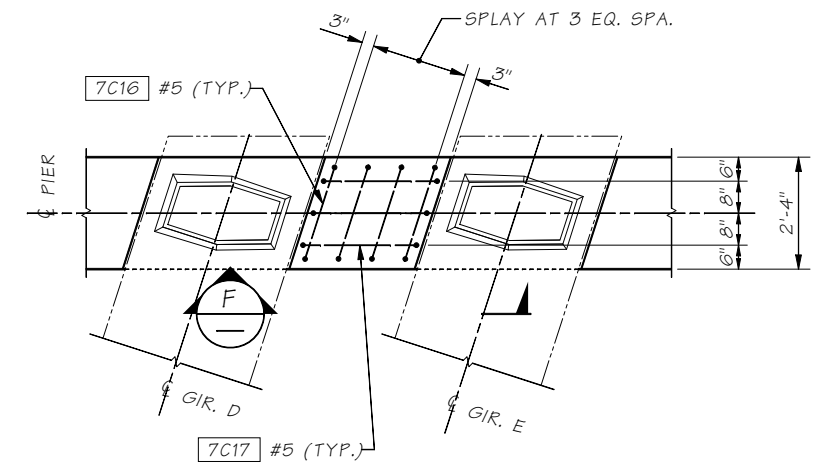

GIRDER STOP DETAIL
SEE "BEARING DETAILS"

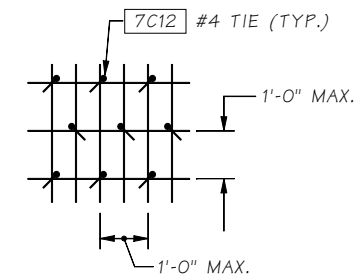

**TIE BAR
SPACING DETAIL**

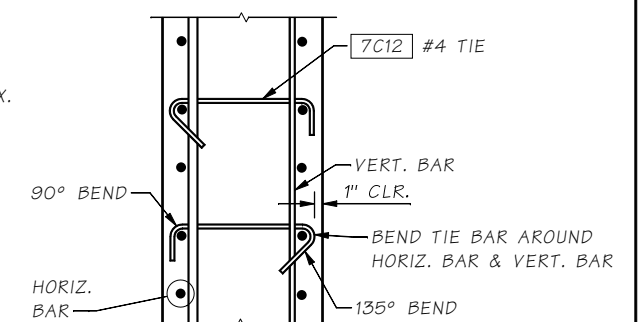

TIE BAR DETAIL
ALTERNATE 135° HOOK EVERY
OTHER TIE BAR

SR 99 FILE NO. SHEET BG141

Bridge Design Engr. Khaleghi, B		M:\Y-Team\AWV SOUTH INTERCHANGE\window files\Pier 7C Details.WND		REGION NO.	STATE	FED. AID PROJ. NO.	SHEET NO.	TOTAL SHEETS
Supervisor	Moore, TM			10	WASH.			
Designed By	Mizumori, A	06/09						
Checked By	Rodda, NT	09/09						
Detailed By	Evans, A	06/09						
Bridge Projects Engr.								
Prelim. Plan By								
Architect/Specialist								
DATE	REVISION	BY	APPD					

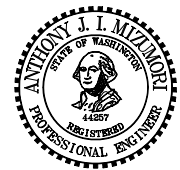

**BRIDGE
AND
STRUCTURES
OFFICE**

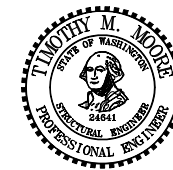

**SR 99
ALASKAN WAY VIADUCT - REPLACEMENT
S HOLGATE ST TO S KING ST - PHASE 2
BRIDGE NO. 99/540 NB & SB
PIER 7C DETAILS**

BRIDGE SHEET NO. BG141
SHEET 987 OF 1475 SHEETS

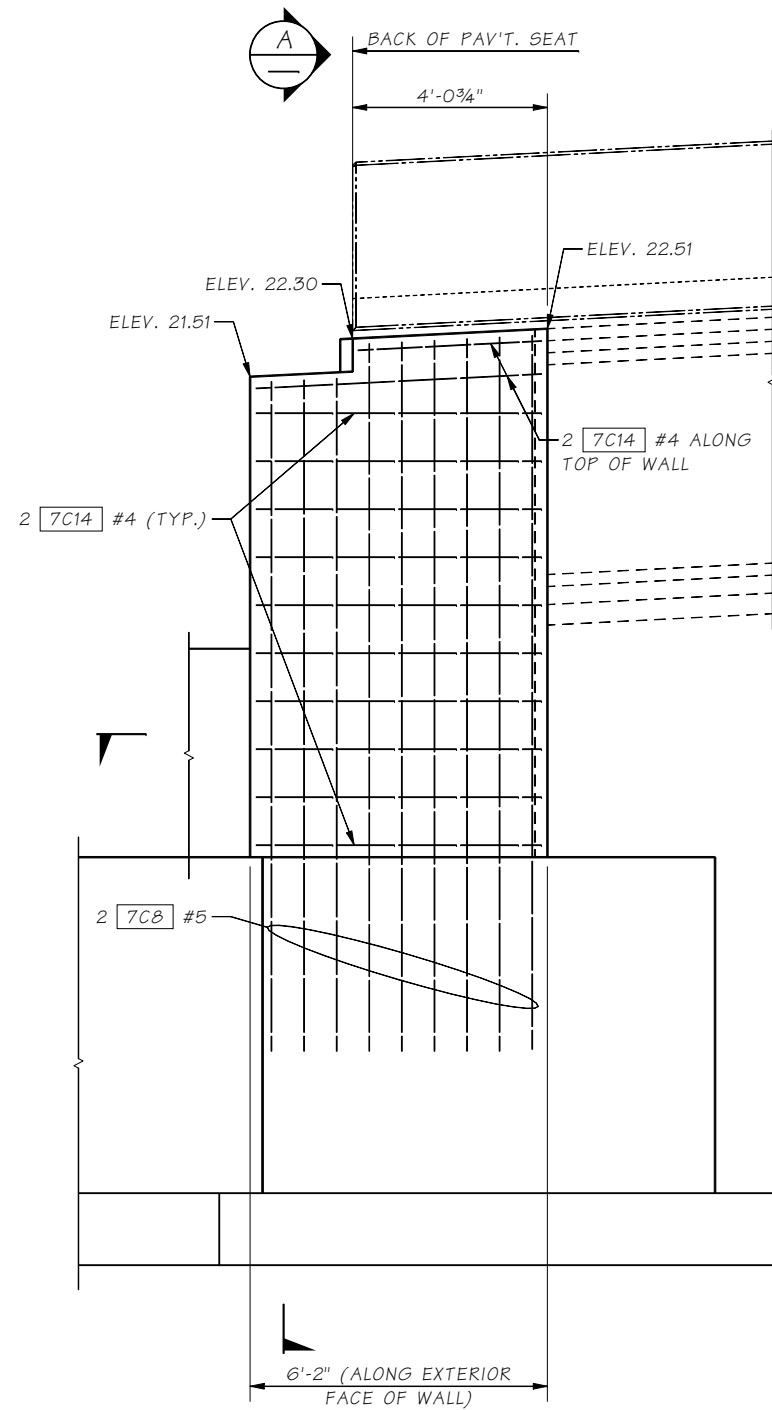

ELEVATION
ELEVATIONS ARE AT THE
EXTERIOR WALL FACE

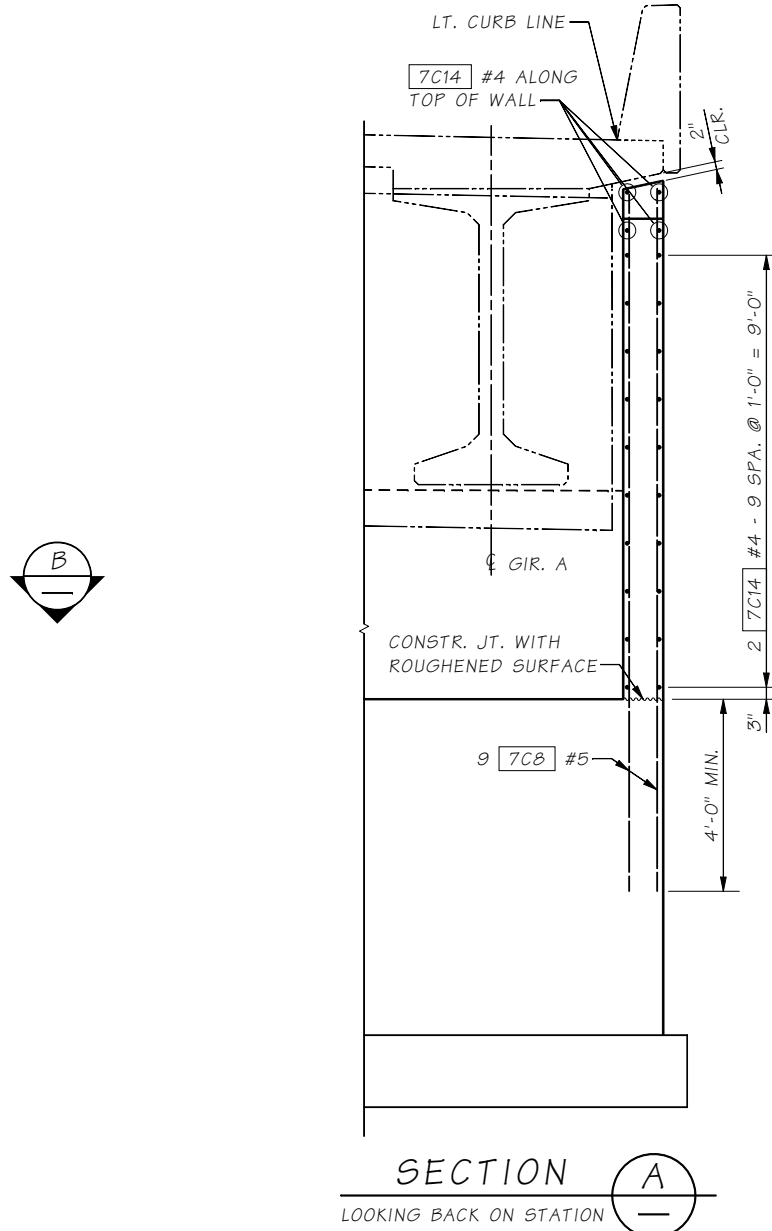

SECTION A
LOOKING BACK ON STATION

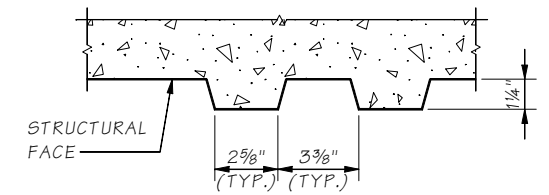

DETAIL C
BG143

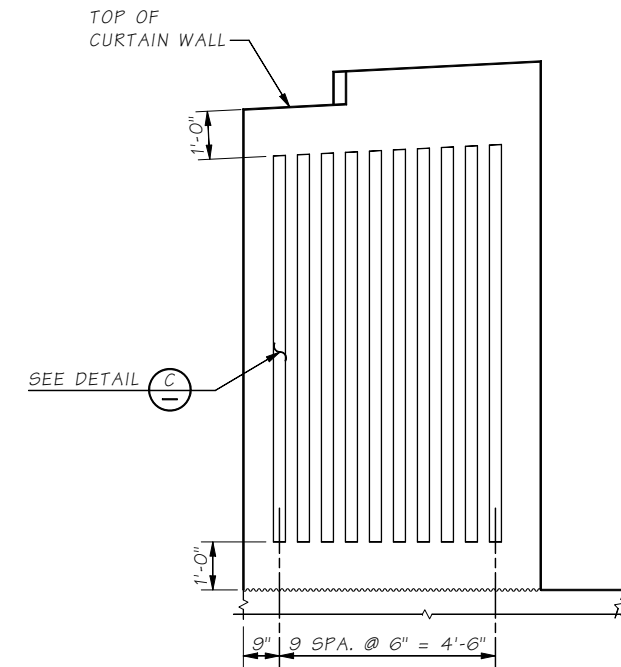

ARCHITECTURAL TREATMENT

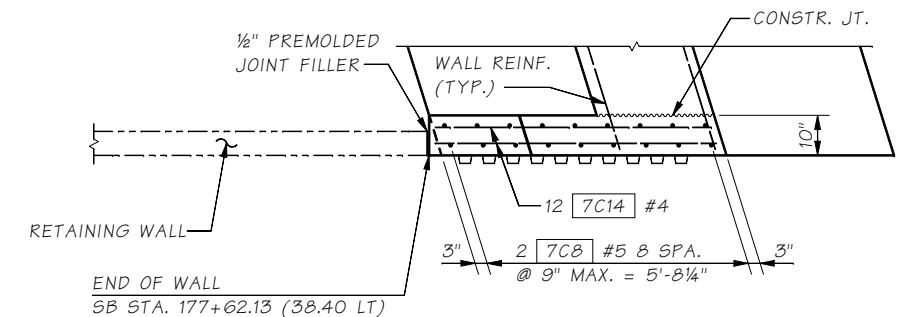

SECTION B

SR 99 FILE NO. SHEET BG142

Bridge Design Engr.	Khaleghi, B	M:\Y-Team\AWV SOUTH INTERCHANGE\window files\Pier 7C Curt wall Dtls 1.WND				REGION NO.	STATE	FED. AID PROJ. NO.	SHEET NO.	TOTAL SHEETS
Supervisor	Moore, TM									
Designed By	Mizumori, A	06/09			10	WASH.				
Checked By	Rodda, NT	09/09								
Detailed By	Evans, A	06/09								
Bridge Projects Engr.										
Prelim. Plan By		2/17/10	REVISED SHEET	AM	TMM					
Architect/Specialist			REVISION	BY	APPD					



BRIDGE AND STRUCTURES OFFICE

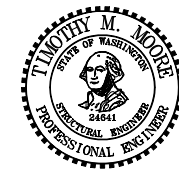

SR 99
ALASKAN WAY VIADUCT - REPLACEMENT
S HOLGATE ST TO S KING ST - PHASE 2
BRIDGE NO. 99/540 NB & SB
PIER 7C CURTAIN WALL
DETAILS 1 OF 2

BRIDGE SHEET NO. **BG142**
SHEET OF **988**
OF **1475**
SHEETS

SR 99 FILE NO. SHEET BG143

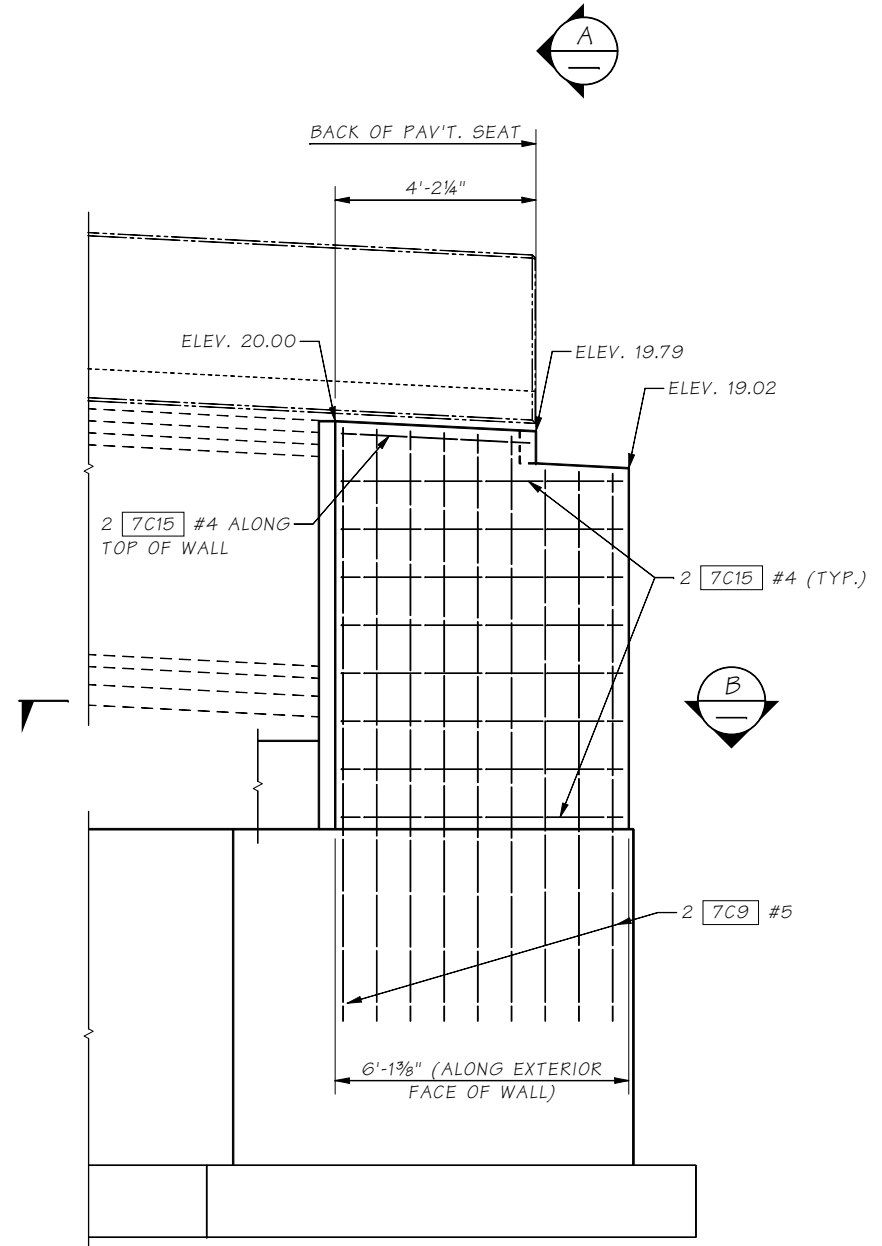

ELEVATION
ELEVATIONS ARE AT THE EXTERIOR WALL FACE

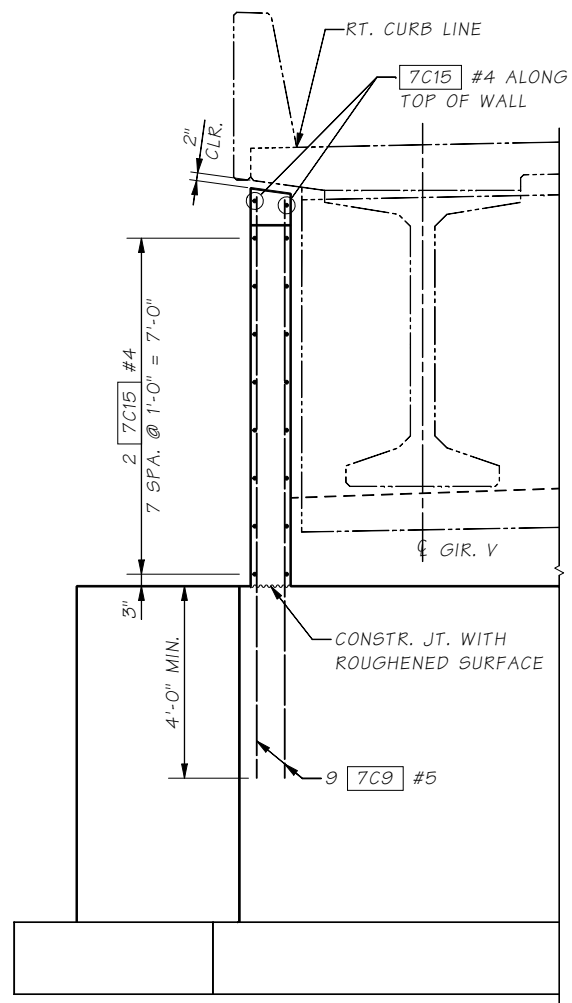

SECTION A
LOOKING BACK ON STATION

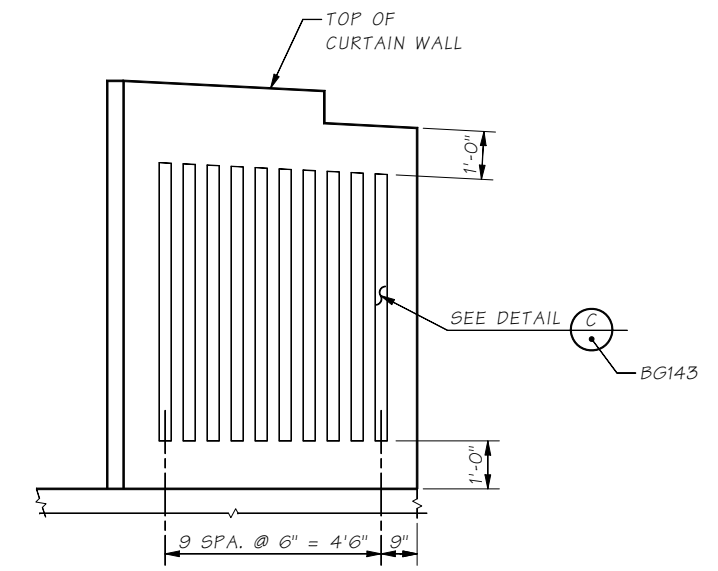

ARCHITECTURAL TREATMENT

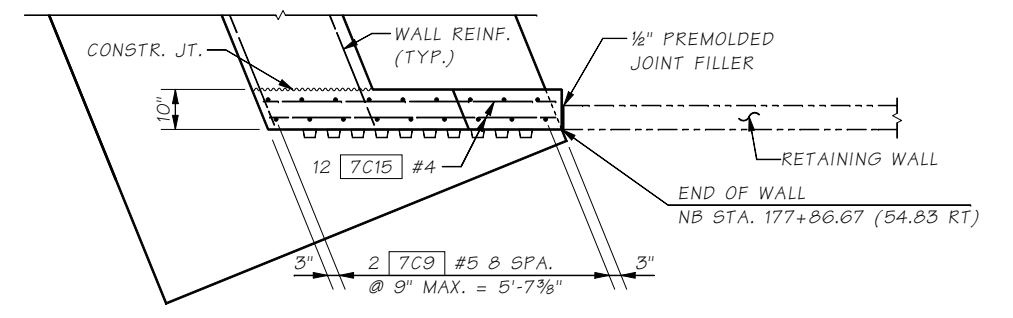

SECTION B

Bridge Design Engr.	Khaleghi, B	M:\Y-Team\AWV SOUTH INTERCHANGE\window files\Pier 7C Curt wall Dtls 2.WND			
Supervisor	Moore, TM	REGION NO.	STATE	FED. AID PROJ. NO.	SHEET NO.
Designed By	Mizumori, A 06/09	10	WASH.		TOTAL SHEETS
Checked By	Rodda, NT 09/09	JOB NUMBER 09A803			
Detailed By	Evans, A 06/09				
Bridge Projects Engr.					
Prelim. Plan By					
Architect/Specialist		DATE	REVISION	BY	APPD



BRIDGE AND STRUCTURES OFFICE

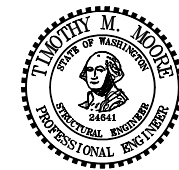

SR 99
ALASKAN WAY VIADUCT - REPLACEMENT
S HOLGATE ST TO S KING ST - PHASE 2
BRIDGE NO. 99/540 NB & SB

PIER 7C CURTAIN WALL
DETAILS 2 OF 2

BRIDGE SHEET NO. **BG143**
SHEET 989 OF 1475 SHEETS

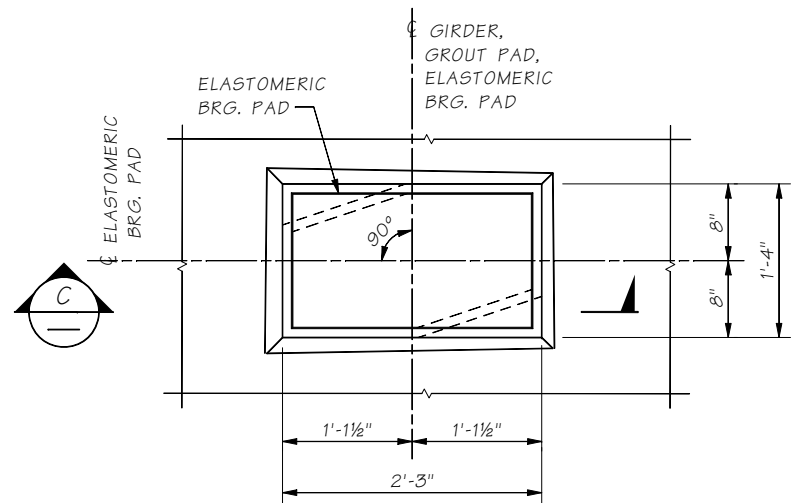

GROUT PAD DETAIL

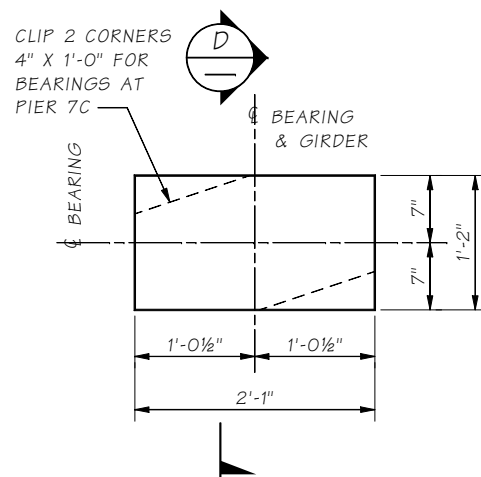

ELASTOMERIC BEARING PAD

DUROMETER 60 HARDNESS

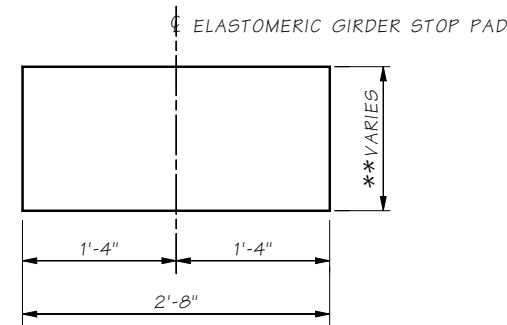

ELASTOMERIC GIRDER STOP PAD

**SEE GIRDER SEAT DETAIL
DUROMETER 60 HARDNESS

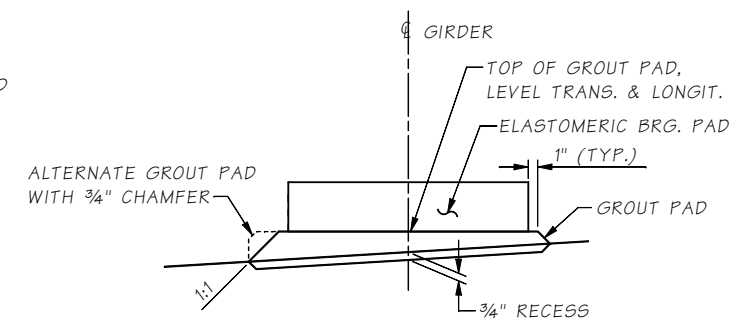

SECTION C

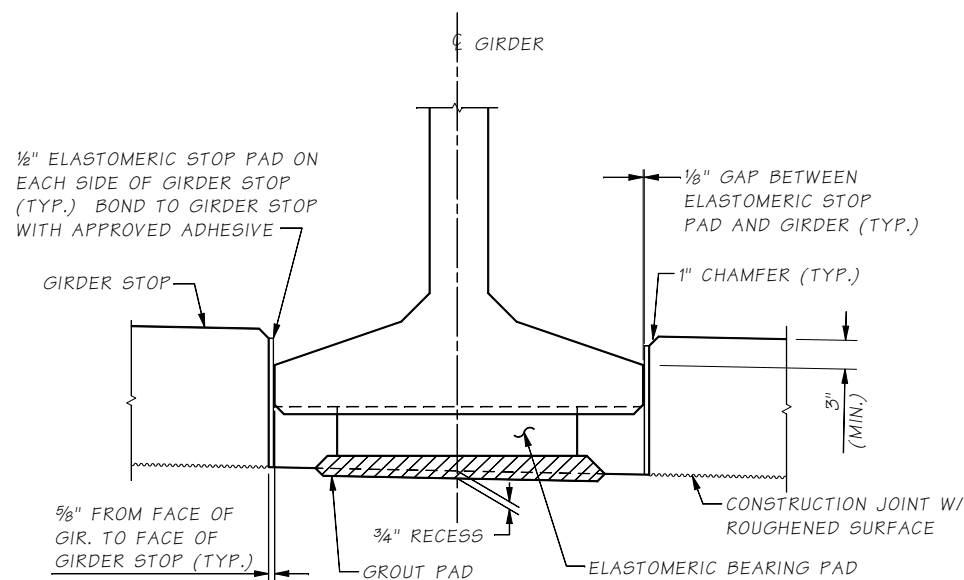

GIRDER SEAT DETAIL

GIRDER STOPS SHALL BE CONSTRUCTED AFTER GIRDER PLACEMENT.

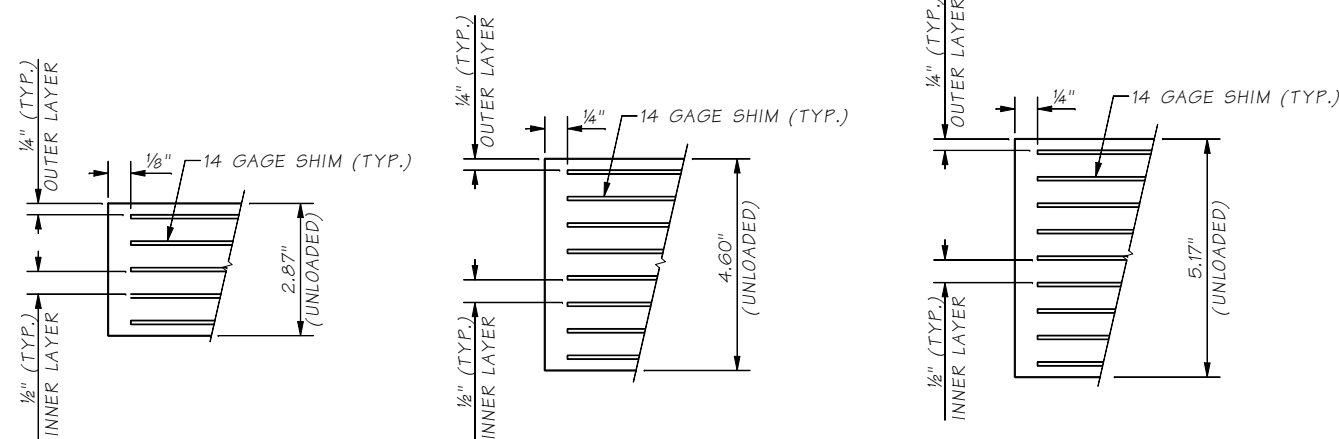

TYPE 2

TYPE 3

TYPE 4

SECTION D

BEARING DESIGN TABLE

SERVICE - I LIMIT STATE

	PIER 1N	PIER 1S	PIER 4N	PIER 4S	PIER 1C, SPAN 6N	PIER 1C, SPAN 7S	PIER 1C, SPAN 1C	PIER 5C, SPAN 4C	PIER 5C, SPAN 5C	PIER 7C
TYPE	3	3	3	4	3	4	4	4	2	2
DEAD LOAD REACTION	210 KIPS	190 KIPS	200 KIPS	190 KIPS	180 KIPS	180 KIPS	165 KIPS	189 KIPS	129 KIPS	210 KIPS
LIVE LOAD REACTION (W/O IMPACT)	80 KIPS	90 KIPS	90 KIPS	100 KIPS	80 KIPS	90 KIPS	76 KIPS	78 KIPS	65 KIPS	71 KIPS
UNLOADED HEIGHT	4.60 IN.	4.60 IN.	4.60 IN.	5.17 IN.	4.60 IN.	5.17 IN.	5.17 IN.	5.17 IN.	2.87 IN.	2.87 IN.
LOADED HEIGHT (DL)	4.57 IN.	4.57 IN.	4.56 IN.	5.14 IN.	4.57 IN.	5.14 IN.	5.14 IN.	5.14 IN.	2.86 IN.	2.85 IN.
DUROMETER HARDNESS	60	60	60	60	60	60	60	60	60	60
NUMBER REQUIRED	8	7	16	14	8	7	17	17	20	22

SR 99 FILE NO. SHEET BG144

Bridge Design Engr.	Khaleghi, B	M:\Y-Team\AWV SOUTH INTERCHANGE\window files\BEARING DETAILS.WND
Supervisor	Moore, TM	
Designed By	Mizumori, A	09/08
Checked By	Lee, CS	05/09
Detailed By	Hanson, CE	09/08
Bridge Projects Engr.		
Prelim. Plan By		
Architect/Specialist	Dornsife, RJ	09/09
DATE	REVISION	BY APPD

REGION NO.	STATE	FED. AID PROJ. NO.	SHEET NO.	TOTAL SHEETS
10	WASH.			
JOB NUMBER				
09A803				



BRIDGE AND STRUCTURES OFFICE

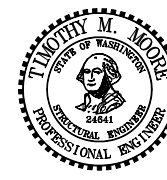

SR 99
ALASKAN WAY VIADUCT - REPLACEMENT
S HOLGATE ST TO S KING ST - PHASE 2
BRIDGE NO. 99/540 NB & SB
BEARING DETAILS

BRIDGE SHEET NO. BG144
SHEET 990 OF 1475 SHEETS

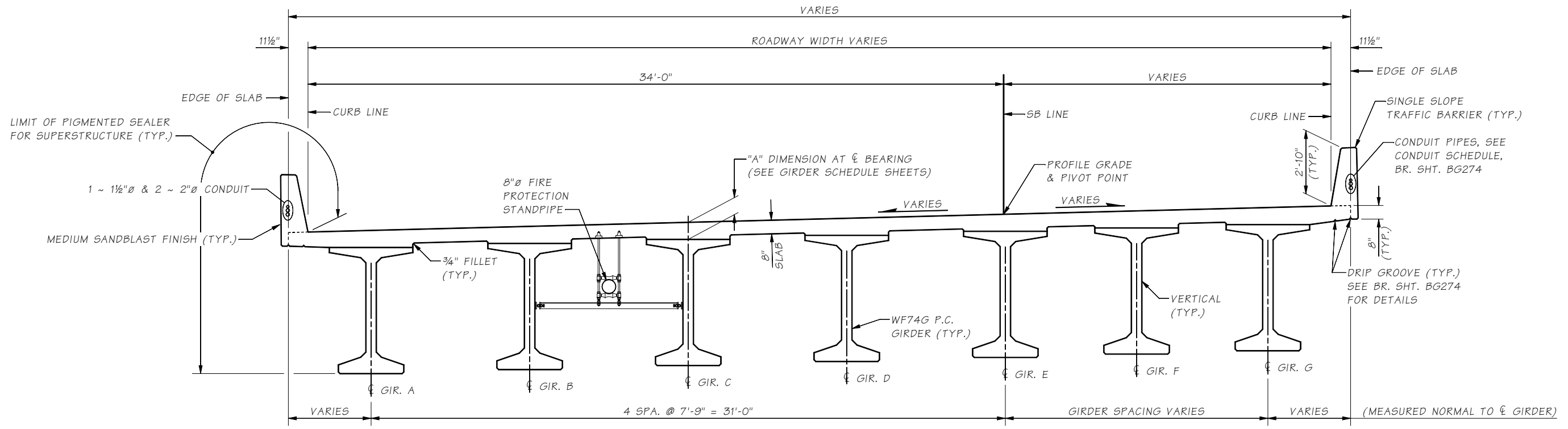

TYPICAL SECTION SB

SHOWN NEAR PIER 65. SEE "SLAB REINFORCEMENT SECTIONS" FOR ADDITIONAL SECTIONS AT OTHER PIERS. TRANSVERSE DIMENSIONS ARE NORMAL TO SB LINE UNLESS AS NOTED.

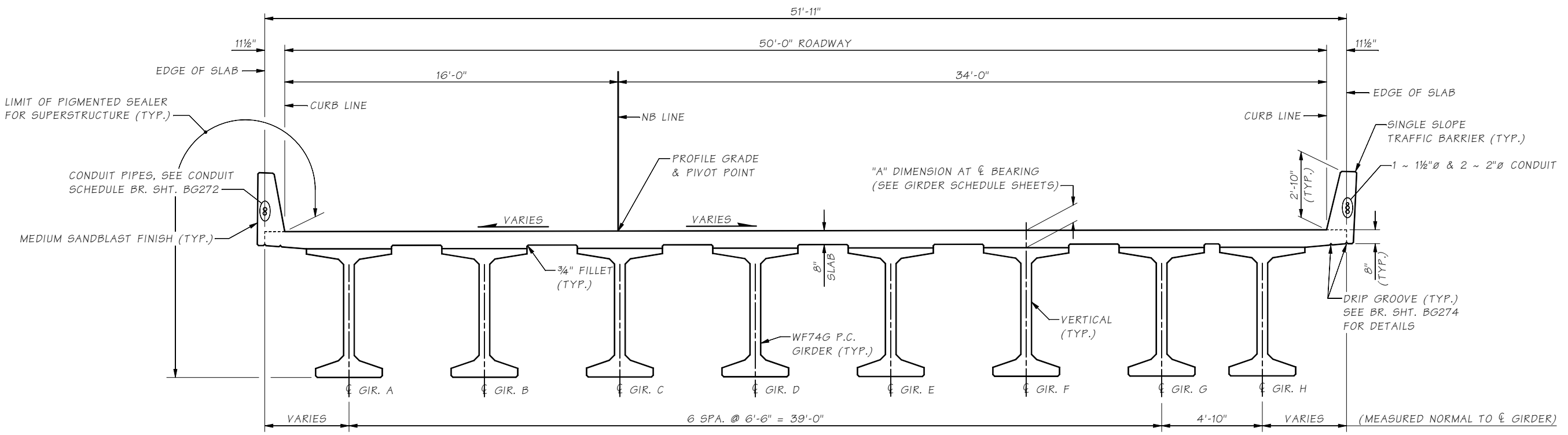

TYPICAL SECTION NB

SHOWN NEAR PIER 6N. SEE "SLAB REINFORCEMENT SECTIONS" FOR ADDITIONAL SECTIONS AT OTHER PIERS. TRANSVERSE DIMENSIONS ARE NORMAL TO NB LINE UNLESS AS NOTED.

SR 99 FILE NO. SHEET BGL45

Bridge Design Engr.	Khaleghi, B	M:\Y-Team\AW SOUTH INTERCHANGE\window files\Typical Sect NB-SB.WND			
Supervisor	Moore, TM	REGION NO.	STATE	FED. AID PROJ. NO.	SHEET NO.
Designed By	Lee, CS 10/08	10	WASH.		TOTAL SHEETS
Checked By	Glassford, P 09/09	JOB NUMBER 09A803			
Detailed By	Hanson, CE 10/08				
Bridge Projects Engr.					
Prelim. Plan By	2/17/10	REVISION	CSL	TMM	
Architect/Specialist		BY	APPD		



BRIDGE AND STRUCTURES OFFICE

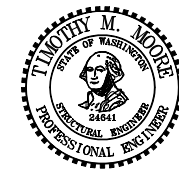

SR 99
ALASKAN WAY VIADUCT - REPLACEMENT
S HOLGATE ST TO S KING ST - PHASE 2
BRIDGE NO. 99/540 NB & SB

TYPICAL SECTION NB & SB

BRIDGE SHEET NO. BGL45
SHEET 991 OF 1475 SHEETS

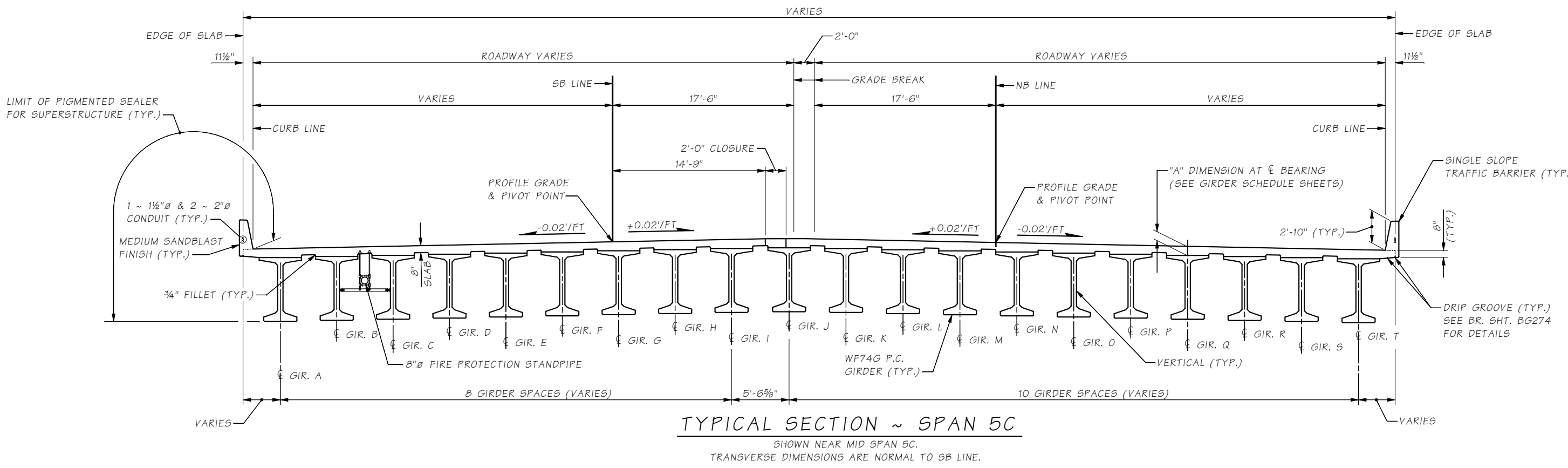
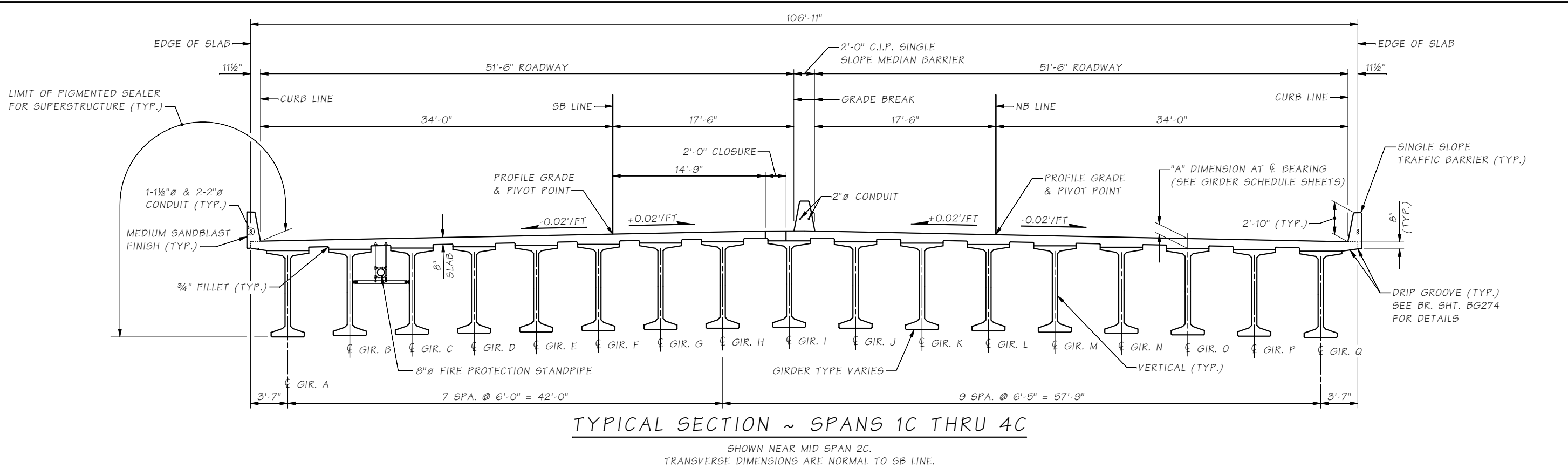

SR 99 FILE NO. SHEET BG146

Bridge Design Engr.	Khaleghi, B	M:\Y-Team\AWV SOUTH INTERCHANGE\window files\Typical Sect Span 1C-5C.WND			
Supervisor	Moore, TM	REGION NO.	STATE	FED. AID PROJ. NO.	SHEET NO.
Designed By	Mizumori, A 10/08	10	WASH.		TOTAL SHEETS
Checked By	Rodda, NT 08/09	JOB NUMBER 09A803			
Detailed By	Evans, A 10/08				
Bridge Projects Engr.		DATE	REVISION	BY	APPD
Prelim. Plan By	2/17/10	REVISED SHEET	CSL	TMM	
Architect/Specialist					

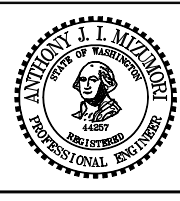

BRIDGE AND STRUCTURES OFFICE

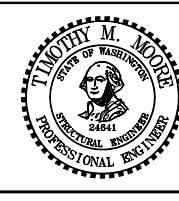

SR 99
ALASKAN WAY VIADUCT - REPLACEMENT
S HOLGATE ST TO S KING ST - PHASE 2
 BRIDGE NO. 99/540 NB & SB

TYPICAL SECTION SPANS 1C TO 5C

BRIDGE SHEET NO. **BG146**
 SHEET 992 OF 1475 SHEETS

SR 99 FILE NO. SHEET BG147

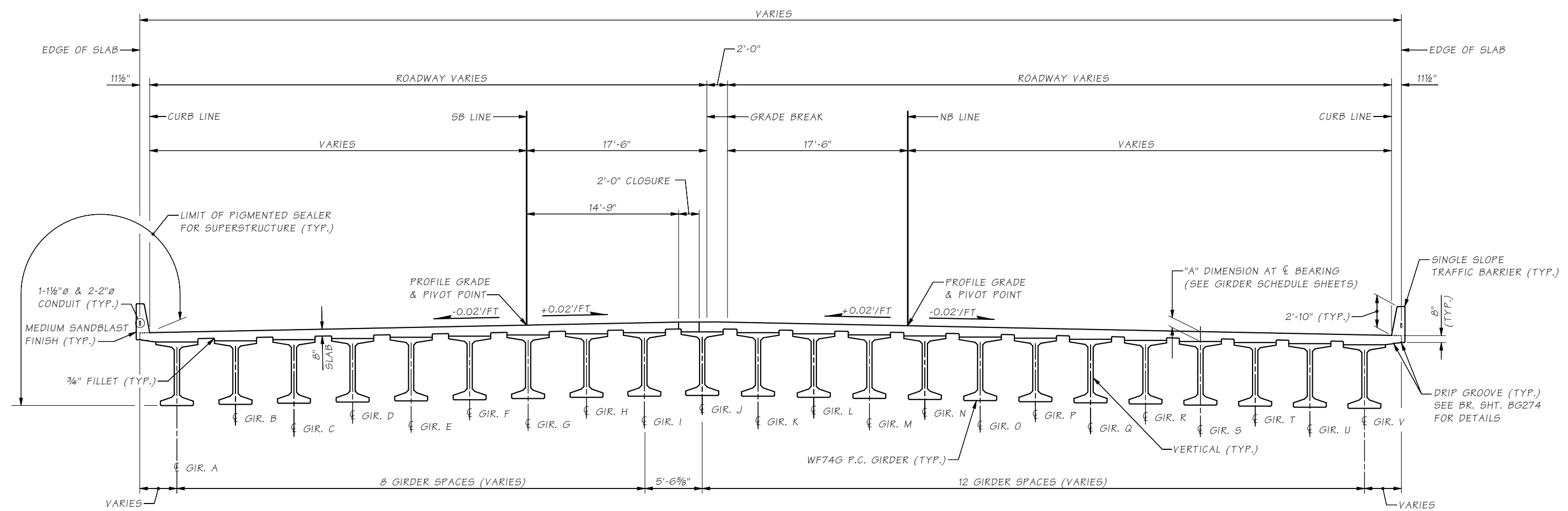

TYPICAL SECTION ~ SPAN 6C
 SHOWN NEAR MID SPAN 6C.
 TRANSVERSE DIMENSIONS ARE NORMAL TO SB LINE.

Bridge Design Engr.	Khaleghi, B	M:\Y-Team\AWV SOUTH INTERCHANGE\window files\Typical Sect 6C.WND	
Supervisor	Moore, TM	REGION NO.	STATE
Designed By	Mizumori, A	10	WASH.
Checked By	Rodda, NT	JOB NUMBER	09A803
Detailed By	Waldron, GA	FED. AID PROJ. NO.	
Bridge Projects Engr.		SHEET NO.	TOTAL SHEETS
Prelim. Plan By	2/17/10	REVISED SHEET	CSL TMM
Architect/Specialist	DATE	REVISION	BY APPD

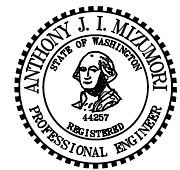

BRIDGE AND STRUCTURES OFFICE

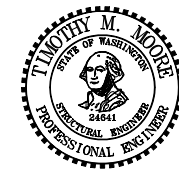

SR 99
 ALASKAN WAY VIADUCT - REPLACEMENT
 S HOLGATE ST TO S KING ST - PHASE 2
 BRIDGE NO. 99/540 NB & SB

TYPICAL SECTION SPAN 6C

BRIDGE SHEET NO. BG147
 SHEET 993 OF 1475 SHEETS

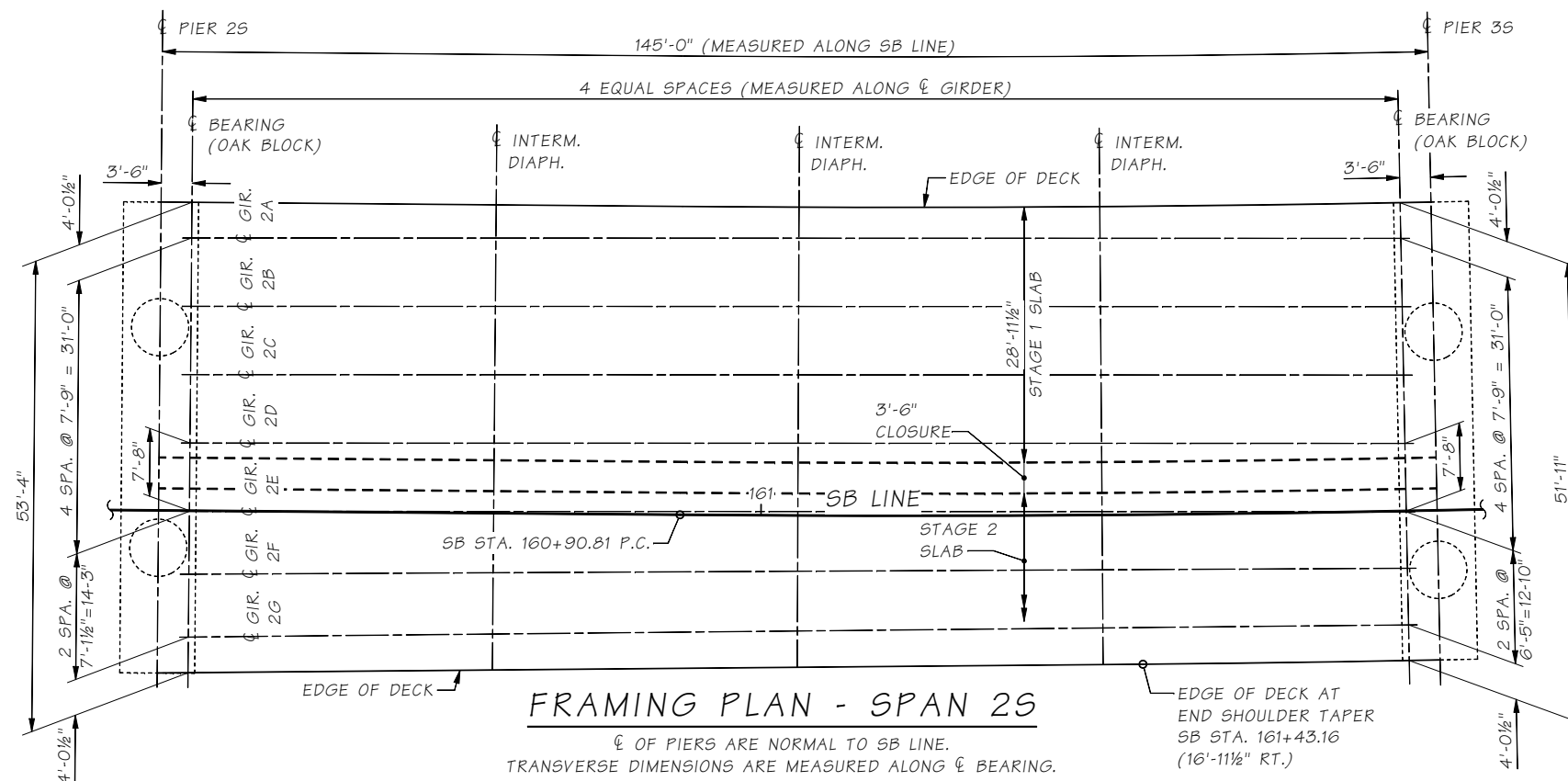
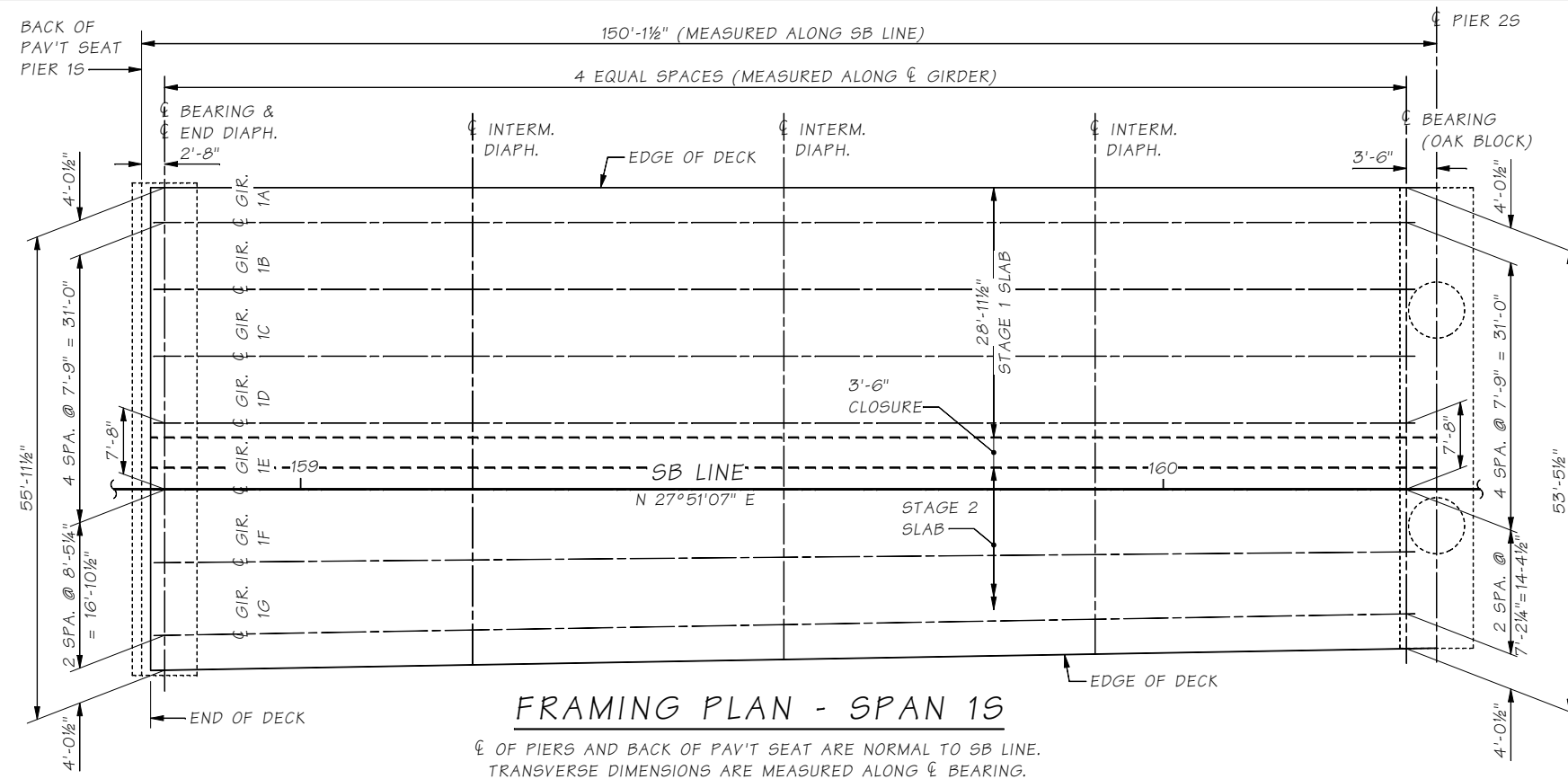

SR 99 FILE NO. SHEET BG148

Bridge Design Engr.	Khaleghi, B	M:\Y-Team\AWV SOUTH INTERCHANGE\window files\Framing Plan Span 1S-2S.WND			
Supervisor	Moore, TM	REGION NO.	STATE	FED. AID PROJ. NO.	SHEET NO.
Designed By	Lee, CS 09/08	10	WASH.		TOTAL SHEETS
Checked By	Glassford, P 09/09	JOB NUMBER			
Detailed By	Hanson, CE 09/08	09A803			
Bridge Projects Engr.		DATE	REVISION	BY	APPD
Prelim. Plan By					
Architect/Specialist					



BRIDGE AND STRUCTURES OFFICE

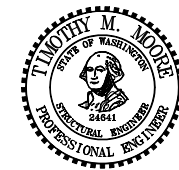

SR 99
ALASKAN WAY VIADUCT - REPLACEMENT
S HOLGATE ST TO S KING ST - PHASE 2
BRIDGE NO. 99/540 NB & SB
FRAMING PLAN SPANS 1S AND 2S

BRIDGE SHEET NO. BG148
SHEET 994 OF 1475 SHEETS

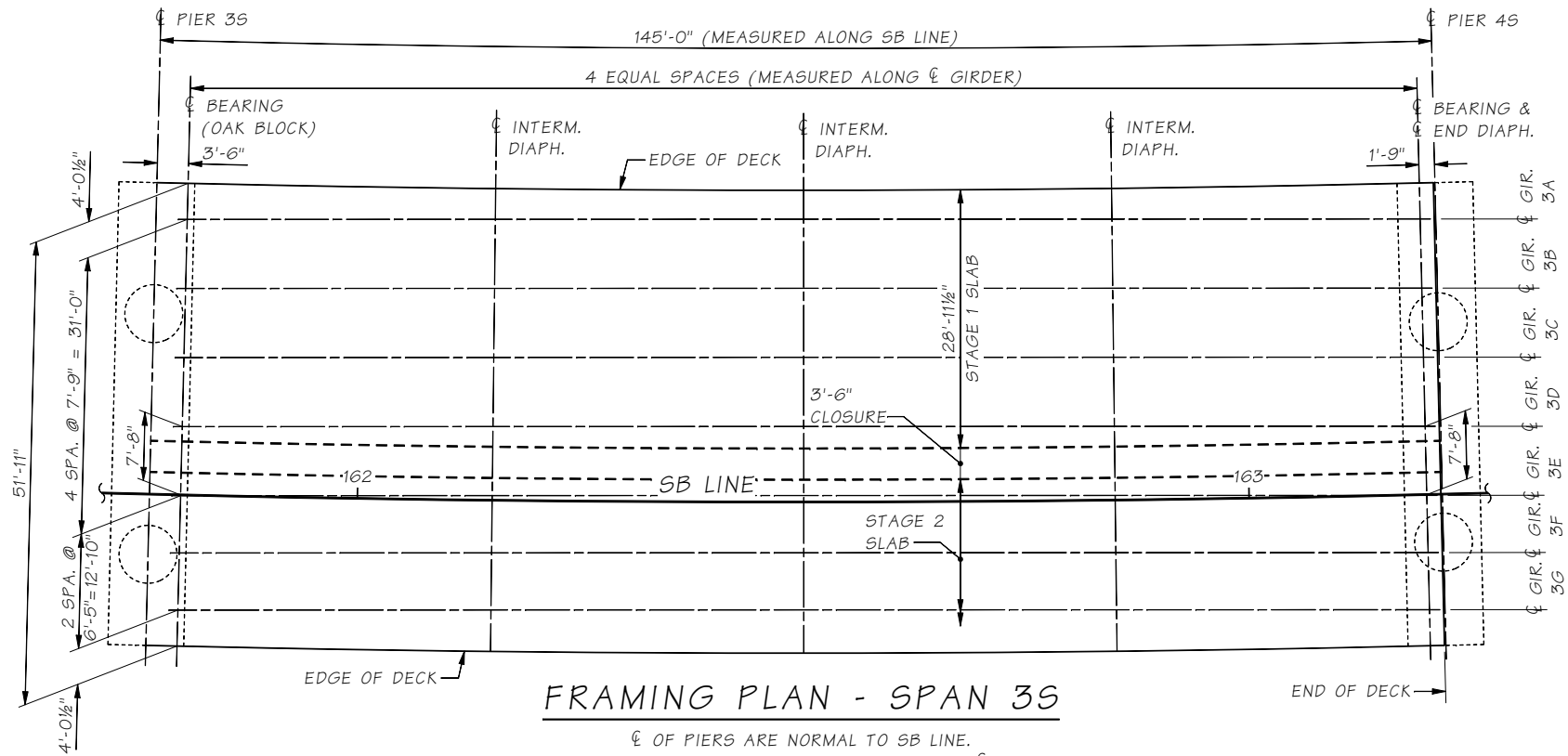

FRAMING PLAN - SPAN 3S
 ☐ OF PIERS ARE NORMAL TO SB LINE.
 TRANSVERSE DIMENSIONS ARE MEASURED ALONG ☐ BEARING.
 ALL GIRDERS ARE PARALLEL.

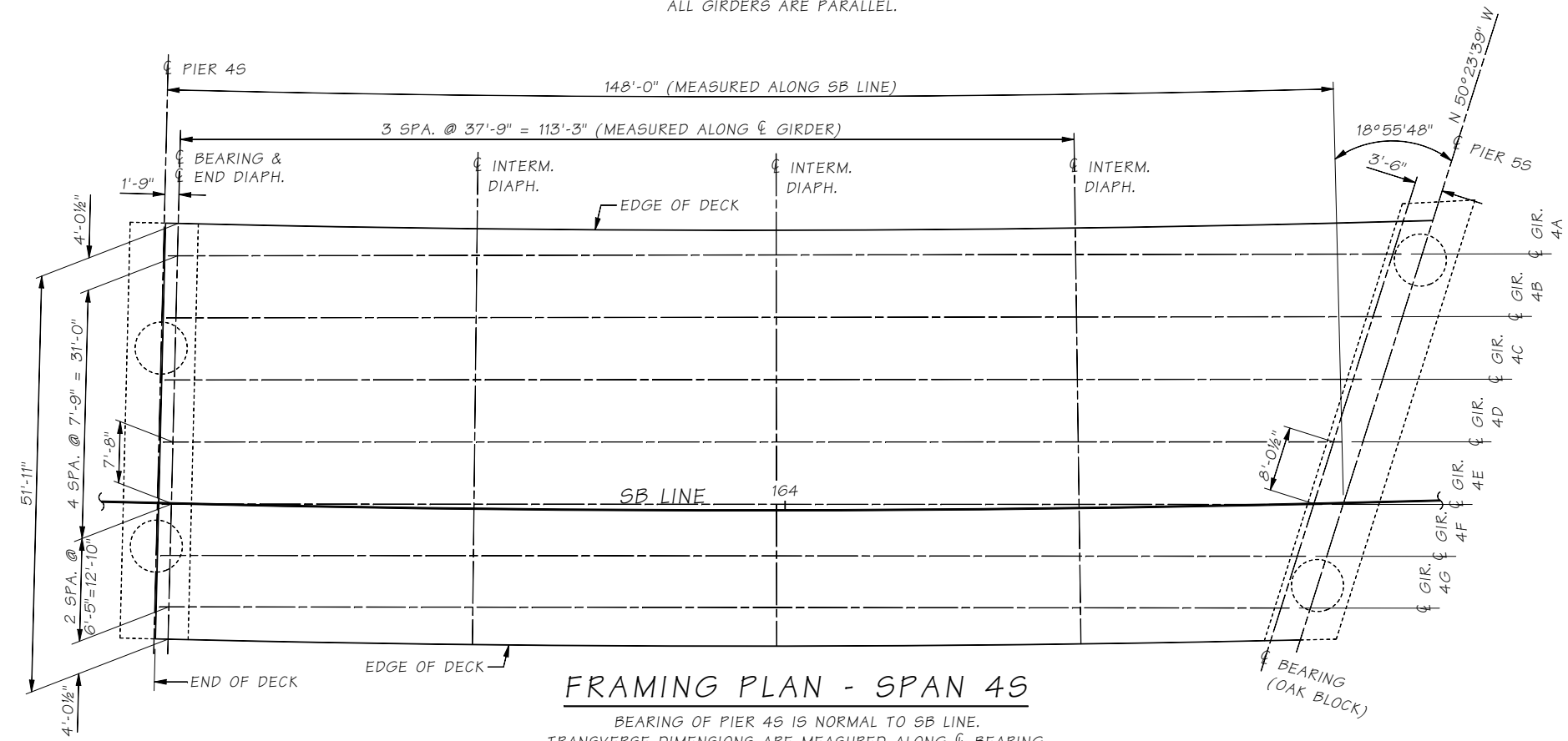

FRAMING PLAN - SPAN 4S
 BEARING OF PIER 4S IS NORMAL TO SB LINE.
 TRANSVERSE DIMENSIONS ARE MEASURED ALONG ☐ BEARING.
 ALL GIRDERS ARE PARALLEL.

SR 99 FILE NO. SHEET BG149

Bridge Design Engr.	Khaleghi, B	M:\Y-Team\AWV SOUTH INTERCHANGE\Window files\Framing Plan Span 3S-4S.WND			
Supervisor	Moore, TM	REGION NO.	STATE	FED. AID PROJ. NO.	SHEET NO.
Designed By	Lee, CS 09/08	10	WASH.		TOTAL SHEETS
Checked By	Glassford, P 09/09	JOB NUMBER			
Detailed By	Hanson, CE 09/08	09A803			
Bridge Projects Engr.		DATE	REVISION	BY	APPD
Prelim. Plan By					
Architect/Specialist					



BRIDGE AND STRUCTURES OFFICE

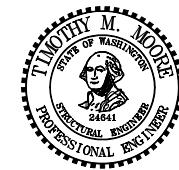

SR 99
ALASKAN WAY VIADUCT - REPLACEMENT
S HOLGATE ST TO S KING ST - PHASE 2
 BRIDGE NO. 99/540 NB & SB
FRAMING PLAN SPANS 3S AND 4S

BRIDGE SHEET NO. **BG149**
 SHEET 995 OF 1475 SHEETS

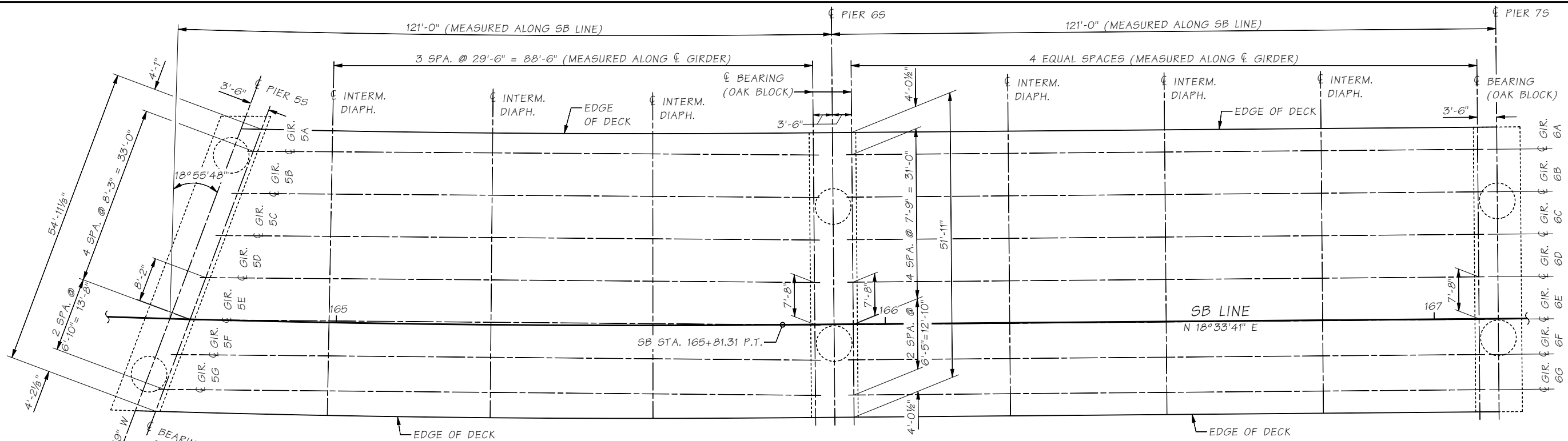

FRAMING PLAN - SPANS 5S AND 6S
 CL OF PIERS 6S & 7S ARE NORMAL TO SB LINE.
 TRANSVERSE DIMENSIONS ARE MEASURED ALONG CL BEARING.
 ALL GIRDERS ARE PARALLEL.

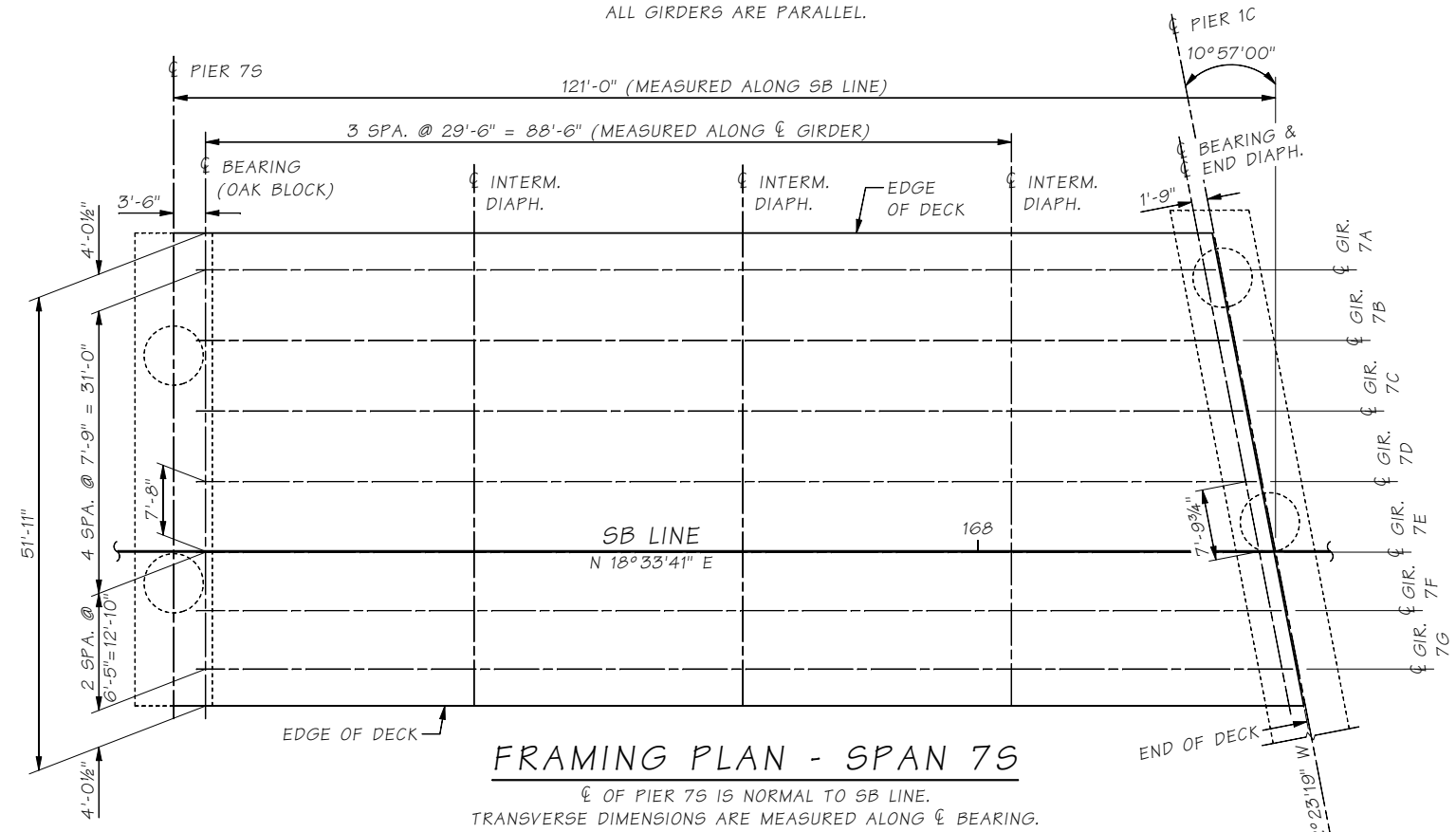

FRAMING PLAN - SPAN 7S
 CL OF PIER 7S IS NORMAL TO SB LINE.
 TRANSVERSE DIMENSIONS ARE MEASURED ALONG CL BEARING.
 ALL GIRDERS ARE PARALLEL.

SR 99 FILE NO. SHEET BG150

Bridge Design Engr.	Khaleghi, B	M:\Y-Team\AWV SOUTH INTERCHANGE\window files\Framing Plan Span 5S-6S-7S.WND			
Supervisor	Moore, TM	REGION NO.	STATE	FED. AID PROJ. NO.	SHEET NO.
Designed By	Lee, CS 09/08	10	WASH.		TOTAL SHEETS
Checked By	Glassford, P 09/09	JOB NUMBER			
Detailed By	Hanson, CE 09/08	09A803			
Bridge Projects Engr.		DATE	REVISION	BY	APPD
Prelim. Plan By					
Architect/Specialist					



BRIDGE AND STRUCTURES OFFICE

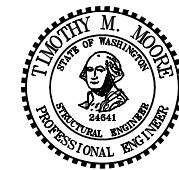

SR 99
ALASKAN WAY VIADUCT - REPLACEMENT
S HOLGATE ST TO S KING ST - PHASE 2
 BRIDGE NO. 99/540 NB & SB

FRAMING PLAN SPANS 5S, 6S AND 7S

BRIDGE SHEET NO. **BG150**
 SHEET 996 OF 1475 SHEETS

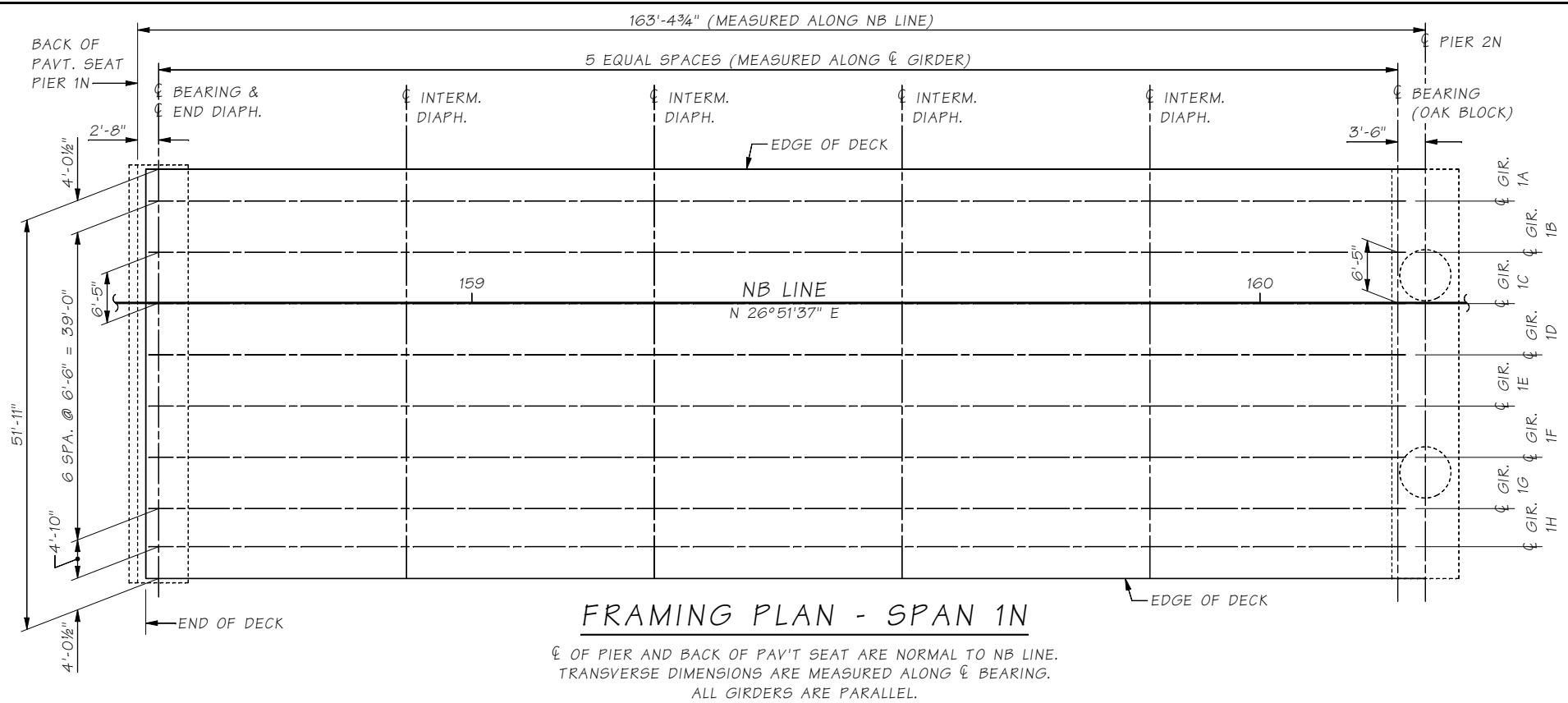

FRAMING PLAN - SPAN 1N
 CL OF PIER AND BACK OF PAV'T SEAT ARE NORMAL TO NB LINE.
 TRANSVERSE DIMENSIONS ARE MEASURED ALONG CL BEARING.
 ALL GIRDERS ARE PARALLEL.

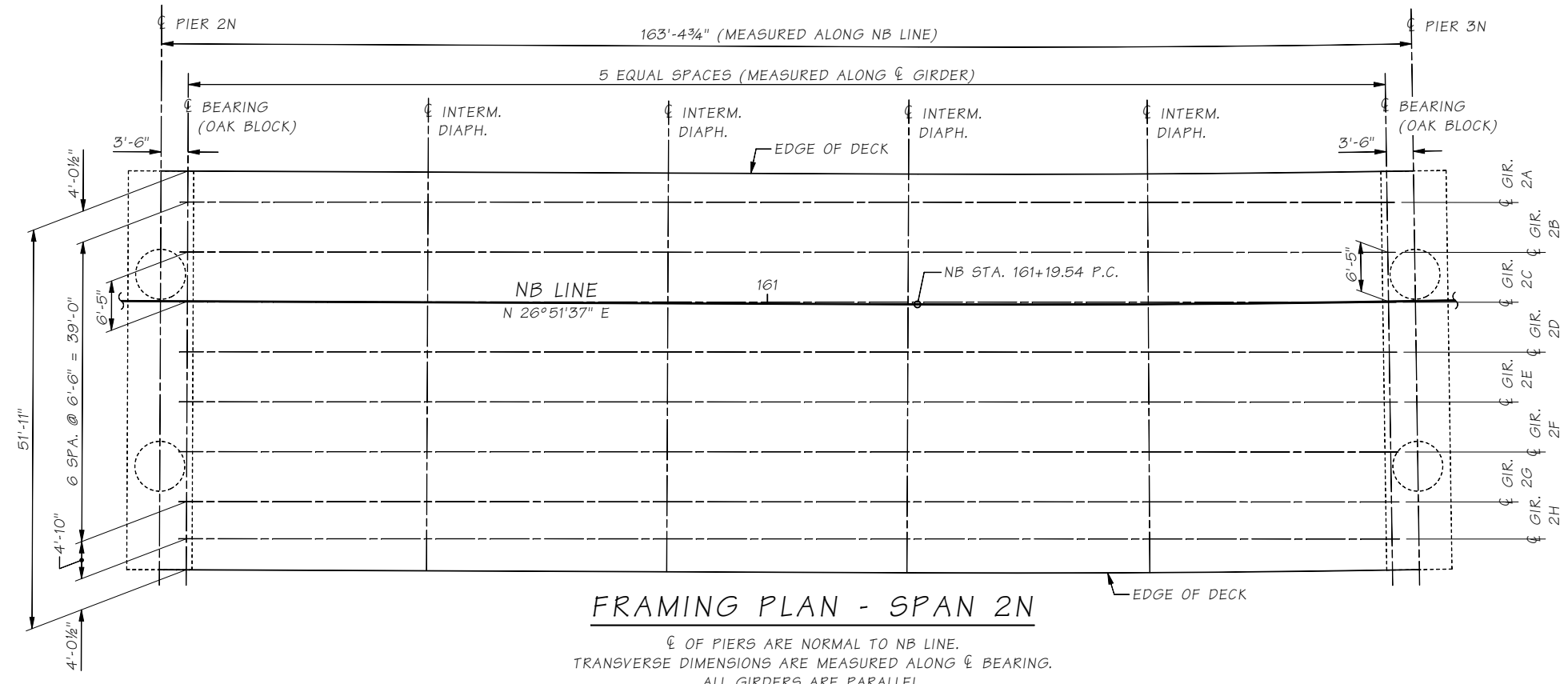

FRAMING PLAN - SPAN 2N
 CL OF PIERS ARE NORMAL TO NB LINE.
 TRANSVERSE DIMENSIONS ARE MEASURED ALONG CL BEARING.
 ALL GIRDERS ARE PARALLEL.

SR 99 FILE NO. SHEET BG151

Bridge Design Engr.	Khaleghi, B	M:\Y-Team\AWV SOUTH INTERCHANGE\window files\Framing Plan Span 1n-2n.wnd			
Supervisor	Moore, TM	REGION NO.	STATE	FED. AID PROJ. NO.	SHEET NO.
Designed By	Lee, CS 09/08	10	WASH.		
Checked By	Glassford, P 09/09	JOB NUMBER 09A803			
Detailed By	Hanson, CE 09/08				
Bridge Projects Engr.					
Prelim. Plan By					
Architect/Specialist		DATE	REVISION	BY	APPD



BRIDGE AND STRUCTURES OFFICE

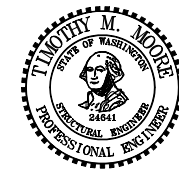

SR 99
ALASKAN WAY VIADUCT - REPLACEMENT
S HOLGATE ST TO S KING ST - PHASE 2
 BRIDGE NO. 99/540 NB & SB
 FRAMING PLAN SPANS 1N AND 2N

BRIDGE SHEET NO. BG151
 SHEET 997 OF 1475 SHEETS

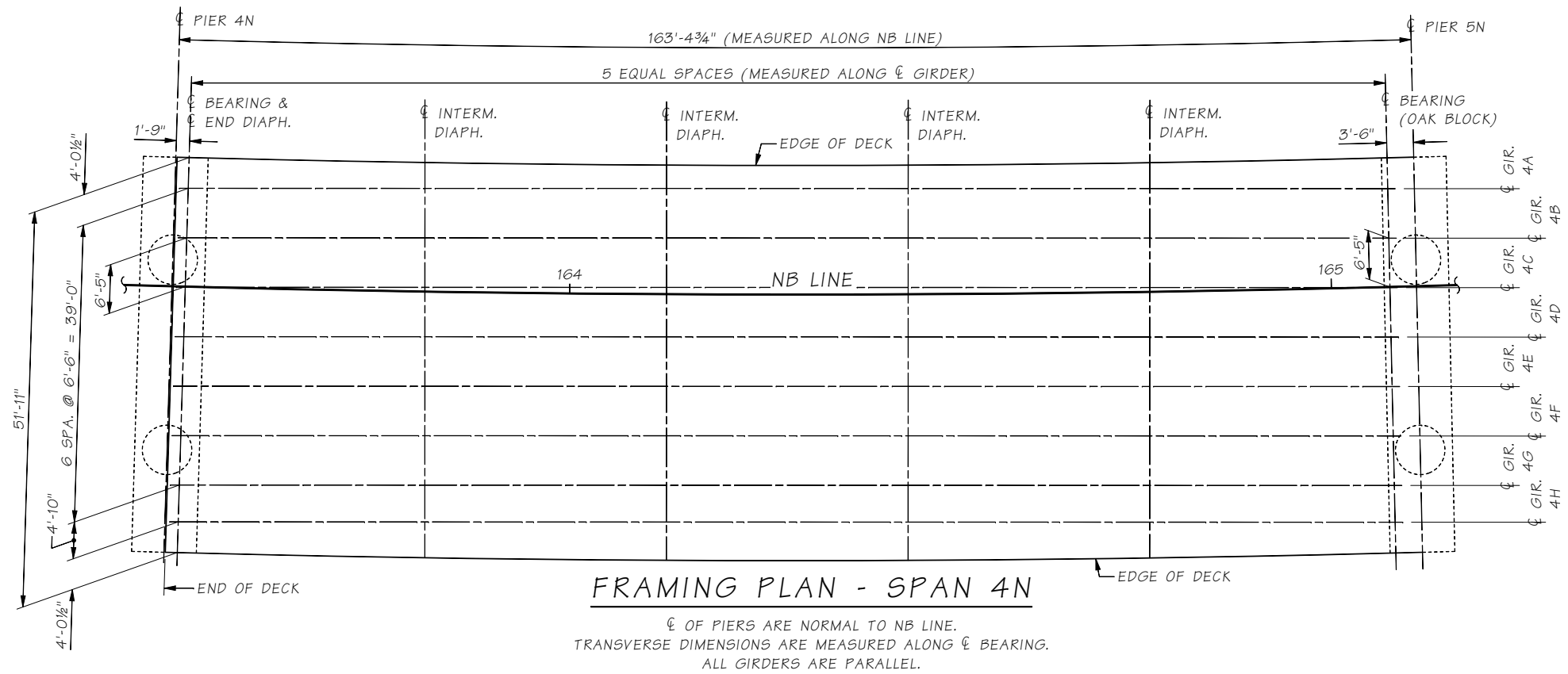
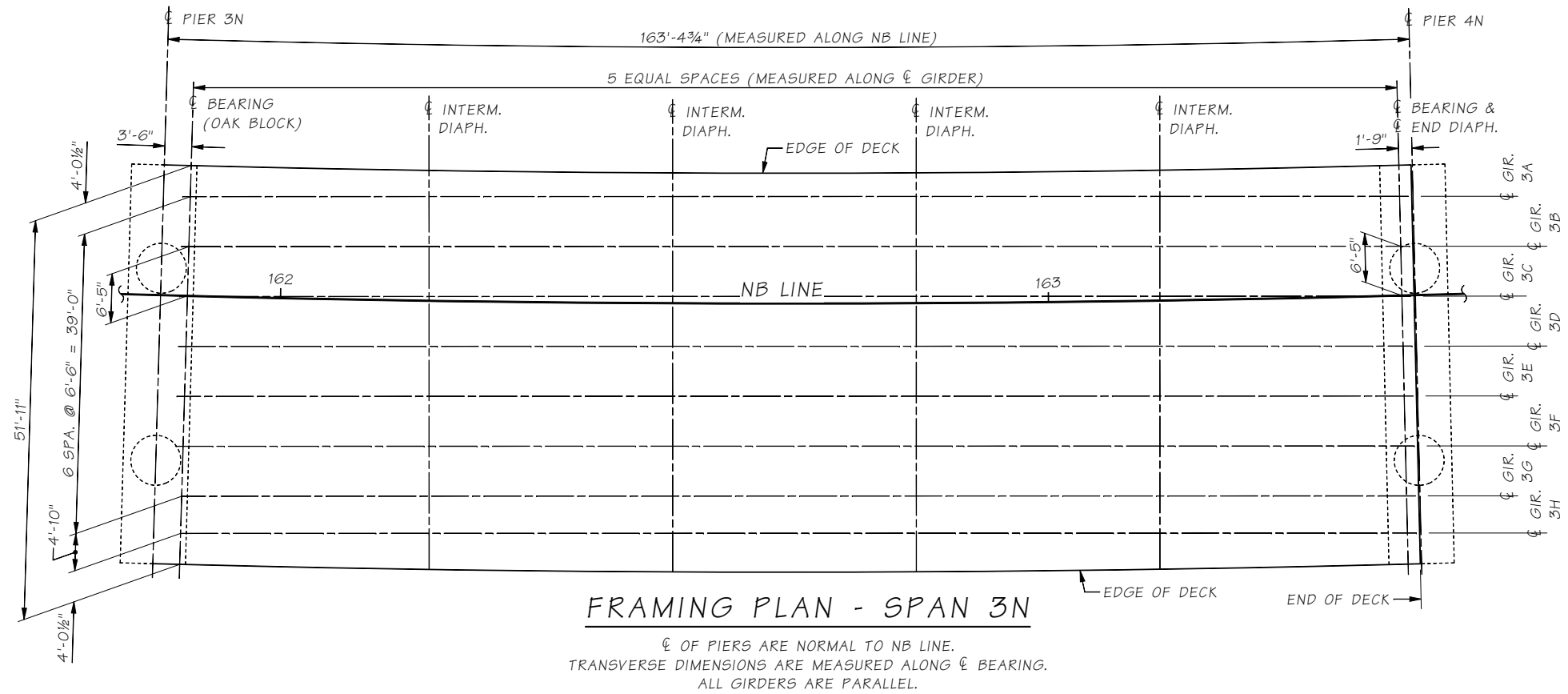

SR 99 FILE NO. SHEET BGL152

Bridge Design Engr.	Khaleghi, B	M:\Y-Team\AWV SOUTH INTERCHANGE\window files\Framing Plan Span 3n-4n.wnd			
Supervisor	Moore, TM	REGION NO.	STATE	FED. AID PROJ. NO.	SHEET NO.
Designed By	Lee, CS 09/08	10	WASH.		TOTAL SHEETS
Checked By	Glassford, P 09/09	JOB NUMBER 09A803			
Detailed By	Hanson, CE 09/08				
Bridge Projects Engr.					
Prelim. Plan By					
Architect/Specialist		DATE	REVISION	BY	APPD



BRIDGE AND STRUCTURES OFFICE

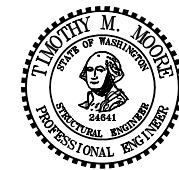

SR 99
ALASKAN WAY VIADUCT - REPLACEMENT
S HOLGATE ST TO S KING ST - PHASE 2
BRIDGE NO. 99/540 NB & SB

FRAMING PLAN SPANS 3N AND 4N

BRIDGE SHEET NO. BGL152
SHEET 998 OF 1475 SHEETS

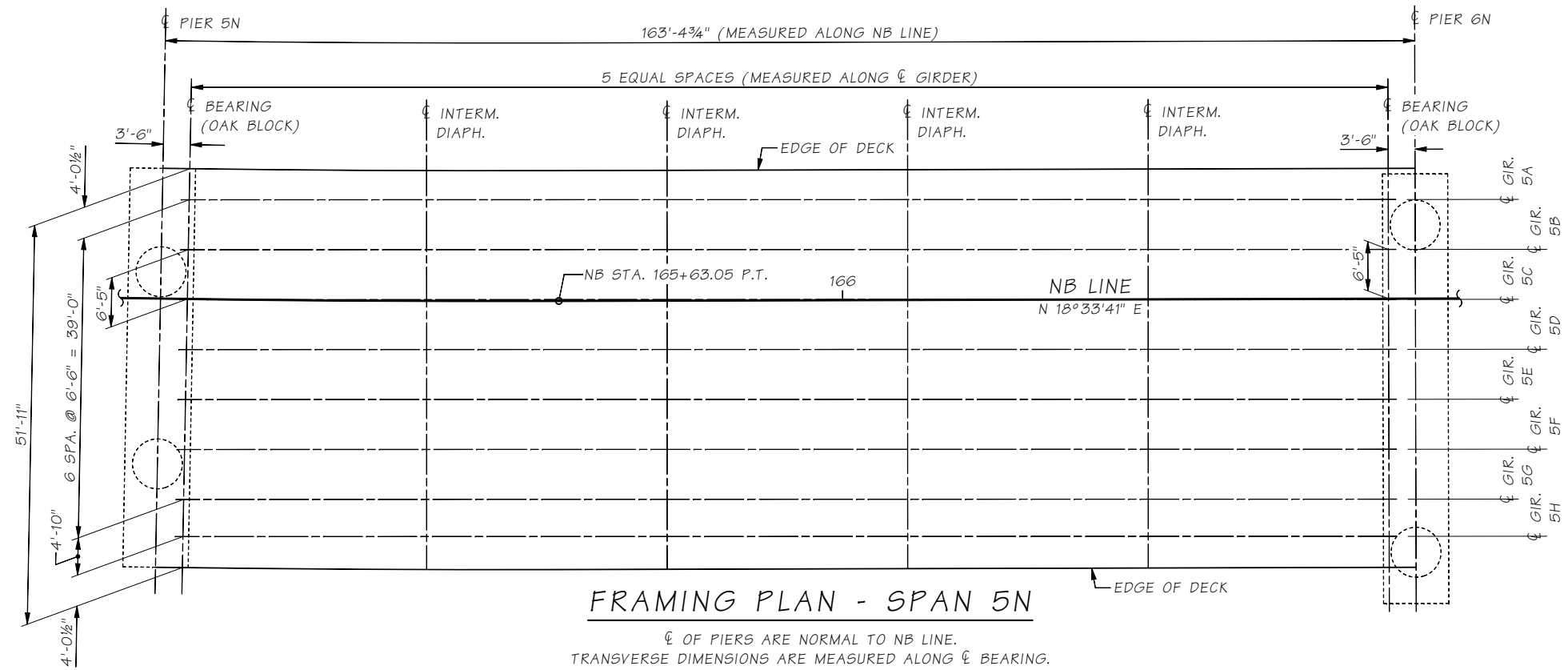

FRAMING PLAN - SPAN 5N
 ☐ OF PIERS ARE NORMAL TO NB LINE.
 TRANSVERSE DIMENSIONS ARE MEASURED ALONG ☐ BEARING.
 ALL GIRDERS ARE PARALLEL.

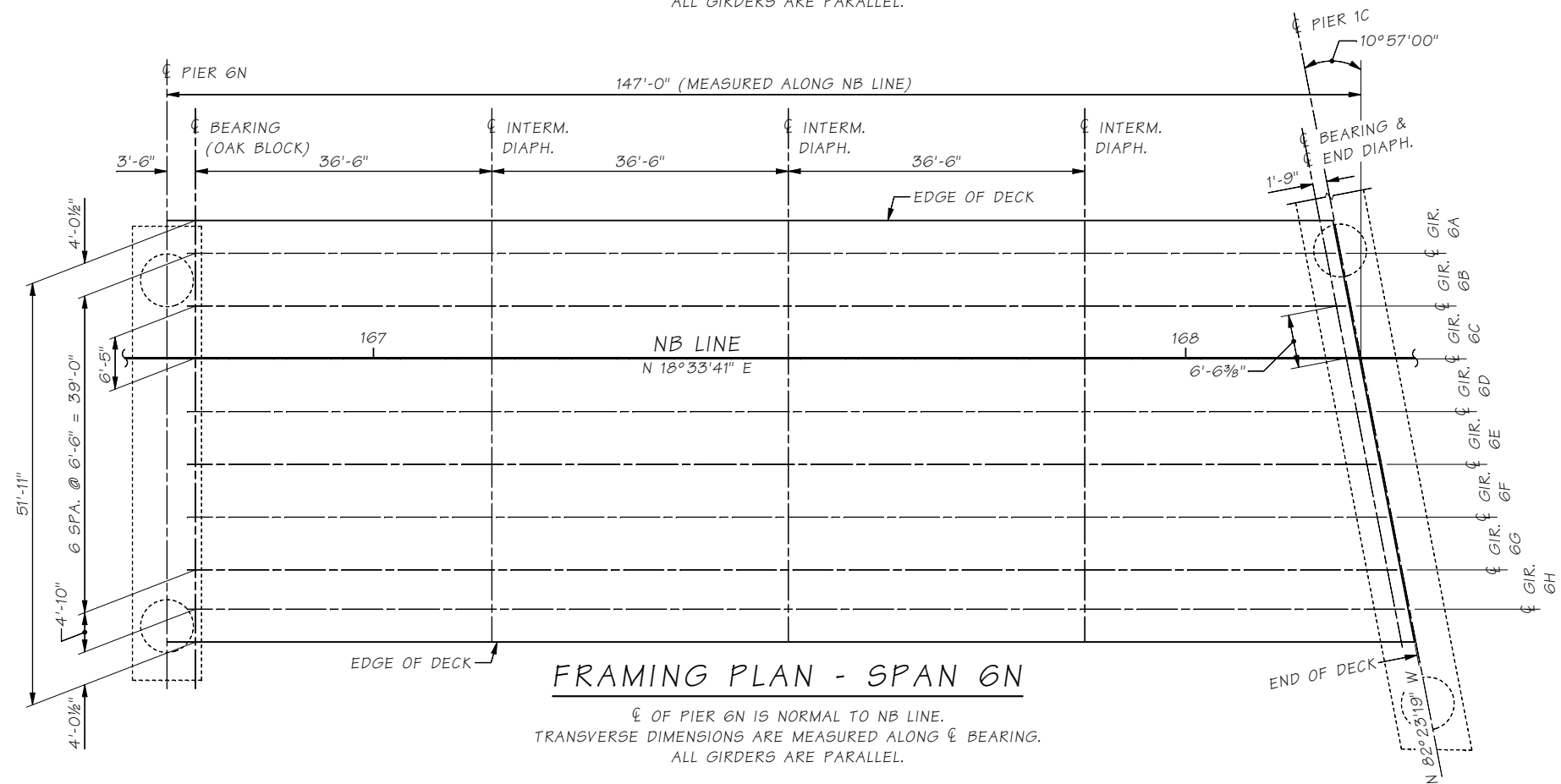

FRAMING PLAN - SPAN 6N
 ☐ OF PIER 6N IS NORMAL TO NB LINE.
 TRANSVERSE DIMENSIONS ARE MEASURED ALONG ☐ BEARING.
 ALL GIRDERS ARE PARALLEL.

SR 99 FILE NO. SHEET BGL53

Bridge Design Engr.	Khaleghi, B	M:\Y-Team\AWV SOUTH INTERCHANGE\window files\Framing Plan Span 5n-6n.WND			
Supervisor	Moore, TM	REGION NO.	STATE	FED. AID PROJ. NO.	SHEET NO.
Designed By	Lee, CS 09/08	10	WASH.		
Checked By	Glassford, P 09/09	JOB NUMBER 09A803			
Detailed By	Hanson, CE 09/08				
Bridge Projects Engr.					
Prelim. Plan By					
Architect/Specialist		DATE	REVISION	BY	APPD



BRIDGE AND STRUCTURES OFFICE

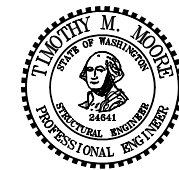

SR 99
ALASKAN WAY VIADUCT - REPLACEMENT
S HOLGATE ST TO S KING ST - PHASE 2
 BRIDGE NO. 99/540 NB & SB
FRAMING PLAN SPANS 5N AND 6N

BRIDGE SHEET NO. **BG153**
 SHEET 999 OF 1475 SHEETS

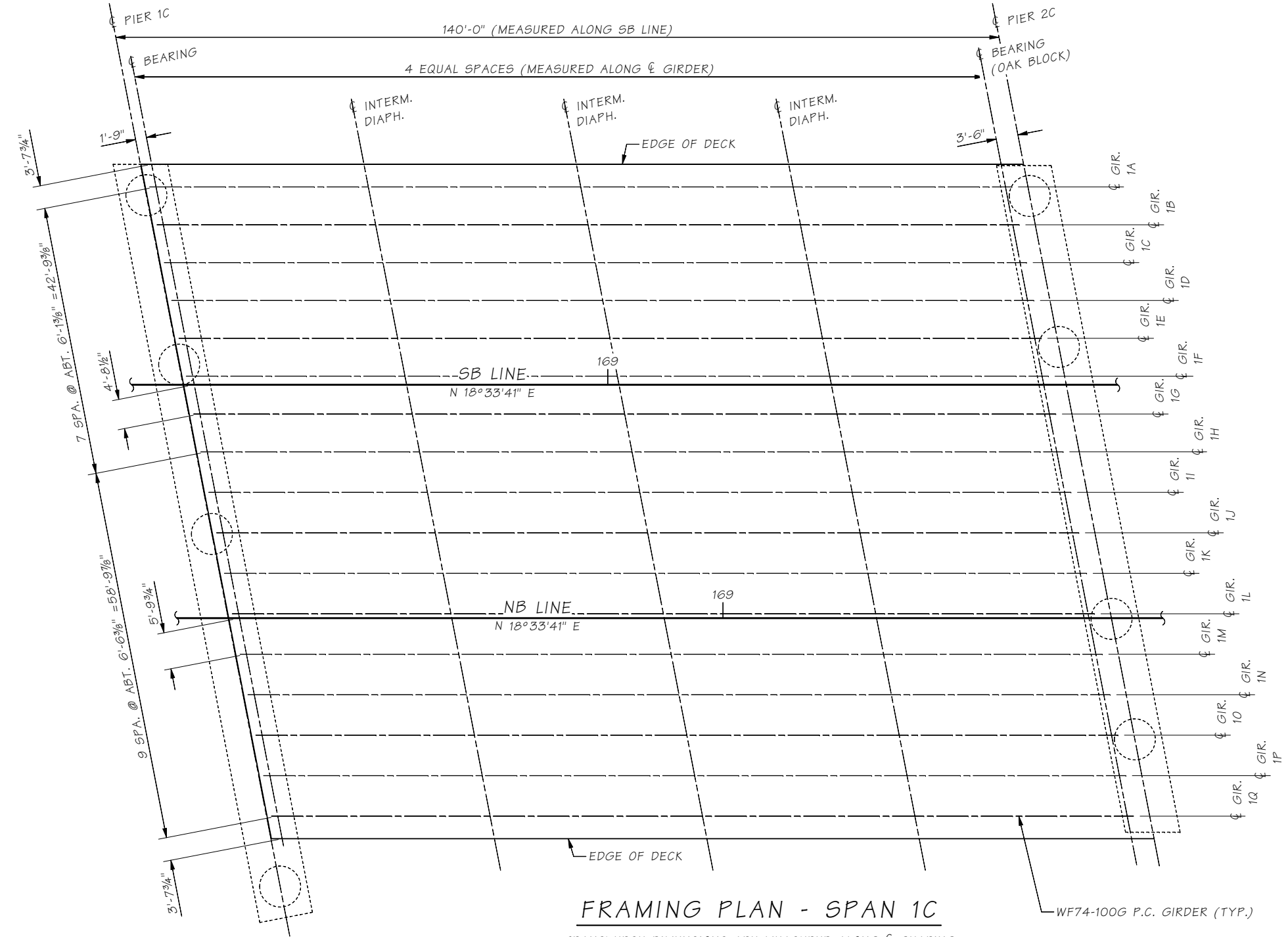

FRAMING PLAN - SPAN 1C
 TRANSVERSE DIMENSIONS ARE MEASURED ALONG ϕ BEARING
 ALL GIRDERS ARE PARALLEL TO SB LINE

Bridge Design Engr.	Khaleghi, B	M:\Y-Team\AWV SOUTH INTERCHANGE\window files\FRAMING PLAN SPAN 1C.WND			
Supervisor	Moore, TM	REGION NO.	STATE	FED. AID PROJ. NO.	SHEET NO.
Designed By	Mizumori, A 10/08	10	WASH.		TOTAL SHEETS
Checked By	Rodda, NT 09/09	JOB NUMBER 09A803			
Detailed By	Evans, A 10/08				
Bridge Projects Engr.					
Prelim. Plan By					
Architect/Specialist		DATE	REVISION	BY	APPD



BRIDGE AND STRUCTURES OFFICE

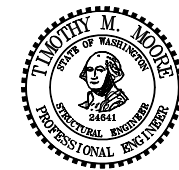

SR 99
 ALASKAN WAY VIADUCT - REPLACEMENT
 S HOLGATE ST TO S KING ST - PHASE 2
 BRIDGE NO. 99/540 NB & SB

FRAMING PLAN SPAN 1C

SR 99 FILE NO. SHEET BGL155

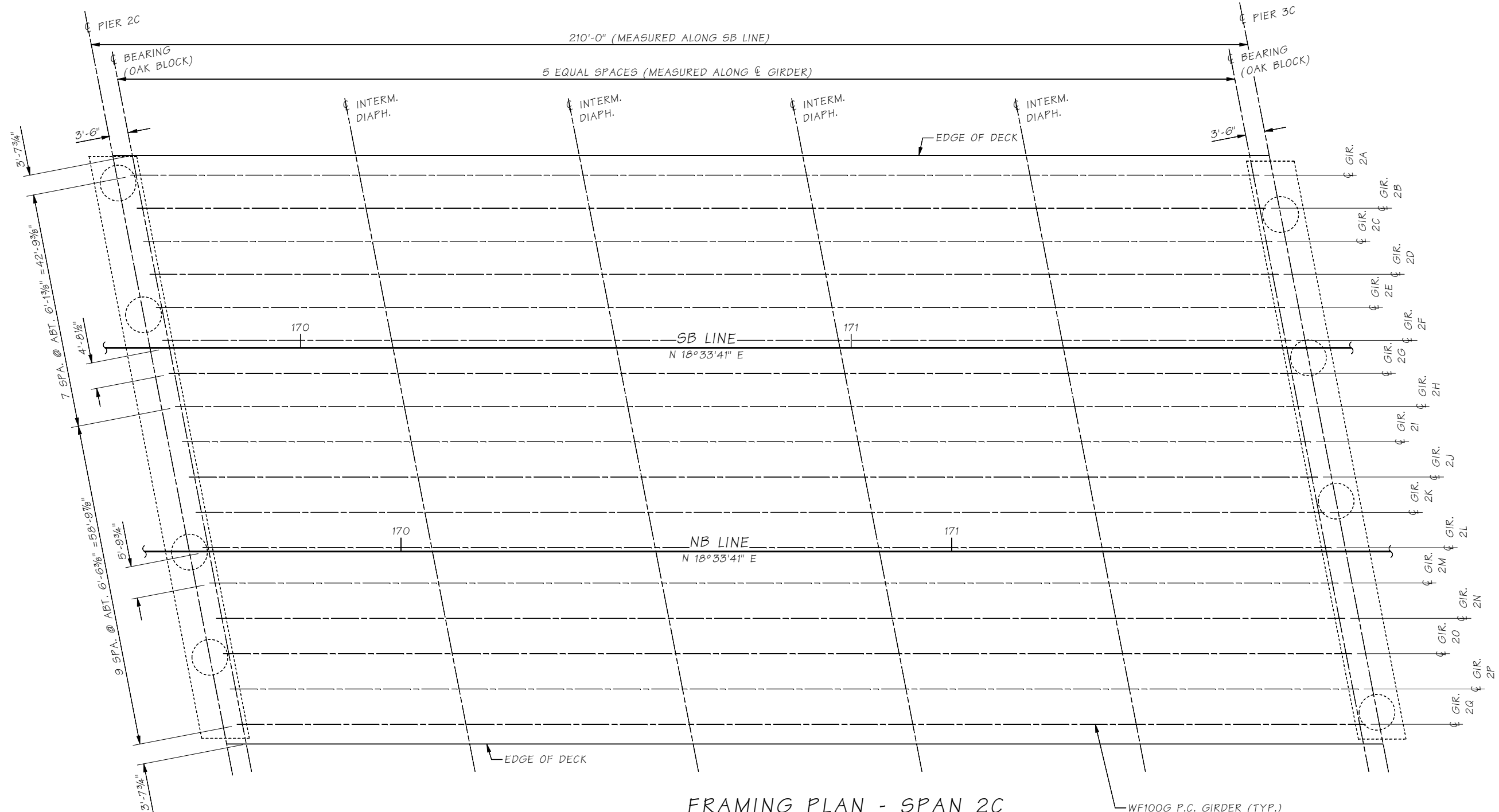

FRAMING PLAN - SPAN 2C
 TRANSVERSE DIMENSIONS ARE MEASURED ALONG ϕ BEARING
 ALL GIRDERS ARE PARALLEL TO SB LINE

Bridge Design Engr.	Khaleghi, B	M:\Y-Team\AWV SOUTH INTERCHANGE\window files\FRAMING PLAN SPAN 2C.WND			
Supervisor	Moore, TM	REGION NO.	STATE	FED. AID PROJ. NO.	SHEET NO.
Designed By	Mizumori, A 10/08	10	WASH.		TOTAL SHEETS
Checked By	Rodda, NT 09/09	JOB NUMBER 09A803			
Detailed By	Evans, A 10/08				
Bridge Projects Engr.		DATE	REVISION	BY	APPD
Prelim. Plan By					
Architect/Specialist					

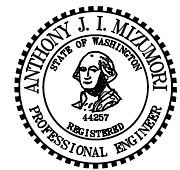

BRIDGE AND STRUCTURES OFFICE

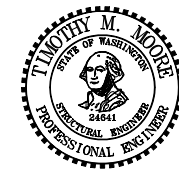

SR 99
 ALASKAN WAY VIADUCT - REPLACEMENT
 S HOLGATE ST TO S KING ST - PHASE 2
 BRIDGE NO. 99/540 NB & SB
 FRAMING PLAN SPAN 2C

BRIDGE SHEET NO. BGL155
 SHEET 1001 OF 1475 SHEETS

Fri Feb 12 13:13:05 2010

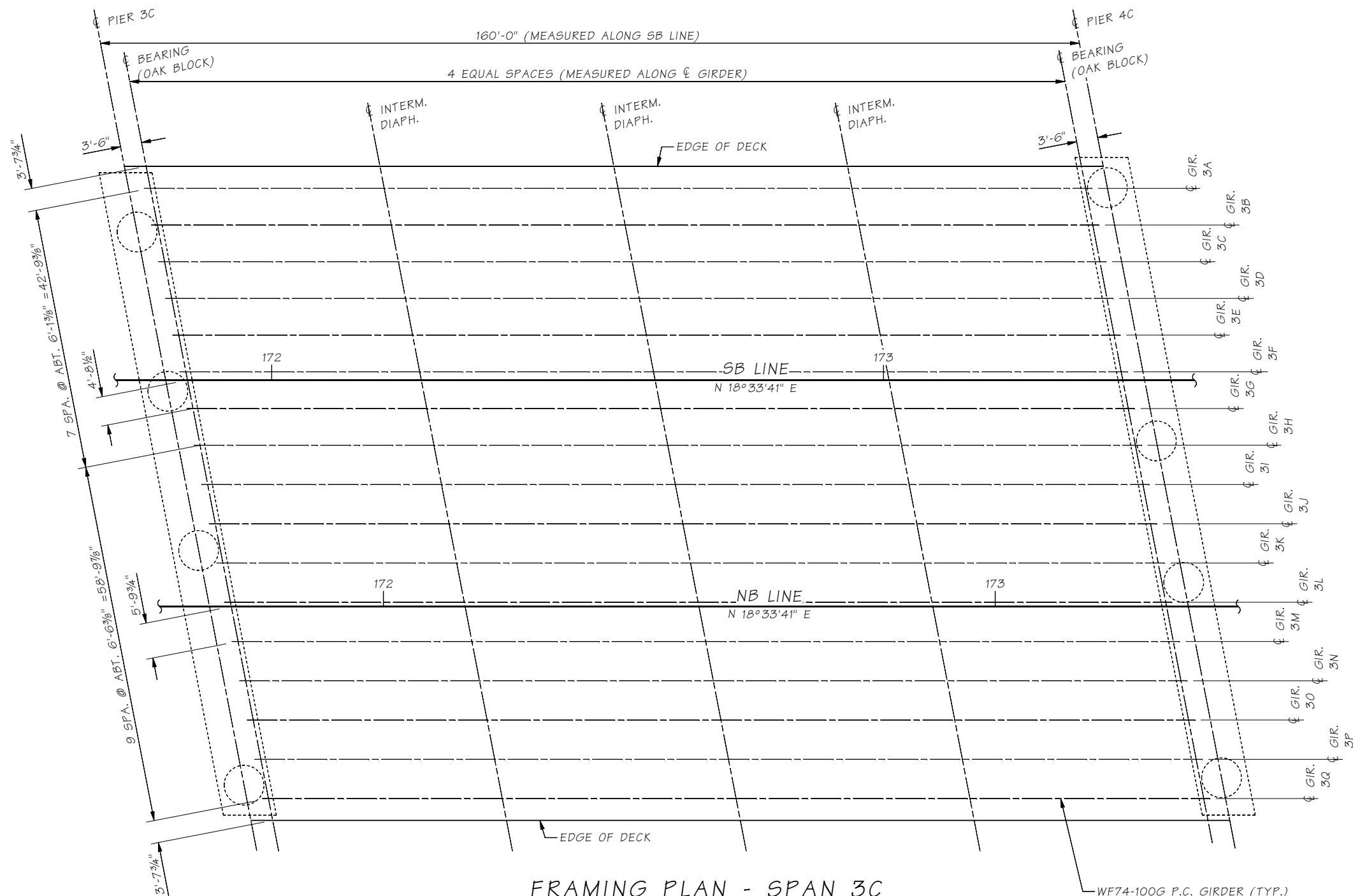

FRAMING PLAN - SPAN 3C

TRANSVERSE DIMENSIONS ARE MEASURED ALONG ϕ BEARING
ALL GIRDERS ARE PARALLEL TO SB LINE

WF74-100G P.C. GIRDER (TYP.)

SR 99 FILE NO. SHEET BG156

Bridge Design Engr.	Khaleghi, B	M:\Y-Team\AW SOUTH INTERCHANGE\window files\FRAMING PLAN SPAN 3C.WND			
Supervisor	Moore, TM	REGION NO.	STATE	FED. AID PROJ. NO.	SHEET NO.
Designed By	Mizumori, A 10/08	10	WASH.		TOTAL SHEETS
Checked By	Rodda, NT 09/09	JOB NUMBER			
Detailed By	Evans, A 10/08	09A803			
Bridge Projects Engr.		DATE	REVISION	BY	APPD
Prelim. Plan By					
Architect/Specialist					

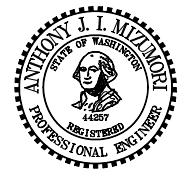

BRIDGE AND STRUCTURES OFFICE

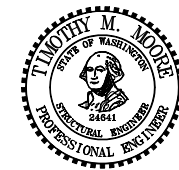

SR 99
ALASKAN WAY VIADUCT - REPLACEMENT
S HOLGATE ST TO S KING ST - PHASE 2
BRIDGE NO. 99/540 NB & SB

FRAMING PLAN SPAN 3C

BRIDGE SHEET NO. BG156
SHEET 1002 OF 1475 SHEETS

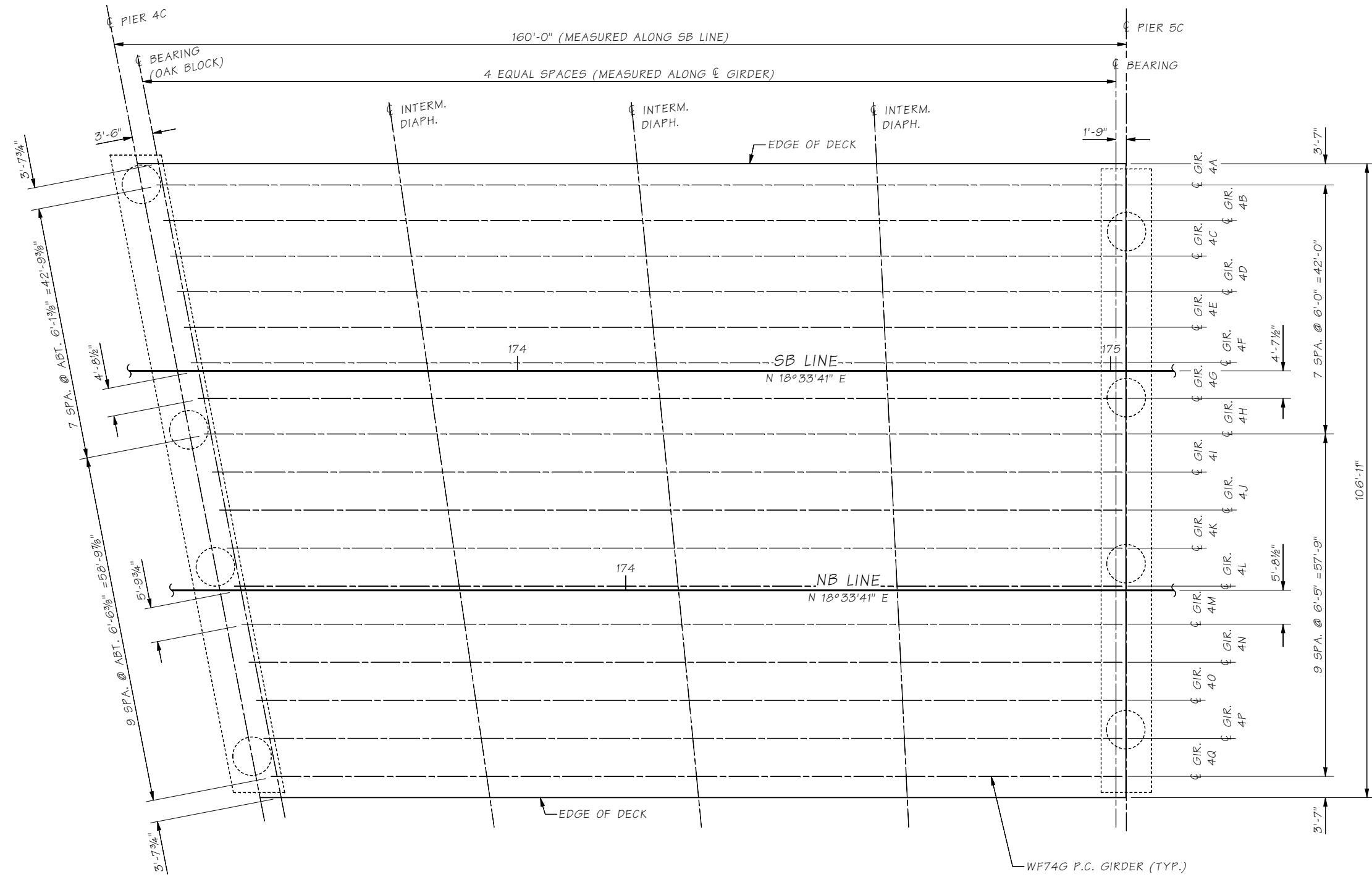

FRAMING PLAN - SPAN 4C
 TRANSVERSE DIMENSIONS ARE MEASURED ALONG BEARING
 ALL GIRDERS ARE PARALLEL TO SB LINE

Bridge Design Engr.	Khaleghi, B	M:\Y-Team\AWV SOUTH INTERCHANGE\window files\FRAMING PLAN SPAN 4C.WND			
Supervisor	Moore, TM	REGION NO.	STATE	FED. AID PROJ. NO.	SHEET NO.
Designed By	Mizumori, A	10	WASH.		TOTAL SHEETS
Checked By	Rodda, NT	JOB NUMBER			
Detailed By	Evans, A	09A803			
Bridge Projects Engr.		DATE	REVISION	BY	APPD
Prelim. Plan By					
Architect/Specialist					



BRIDGE AND STRUCTURES OFFICE

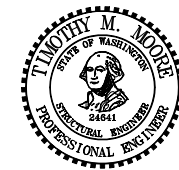

SR 99
 ALASKAN WAY VIADUCT - REPLACEMENT
 S HOLGATE ST TO S KING ST - PHASE 2
 BRIDGE NO. 99/540 NB & SB

FRAMING PLAN SPAN 4C

SR 99 FILE NO. SHEET BG158

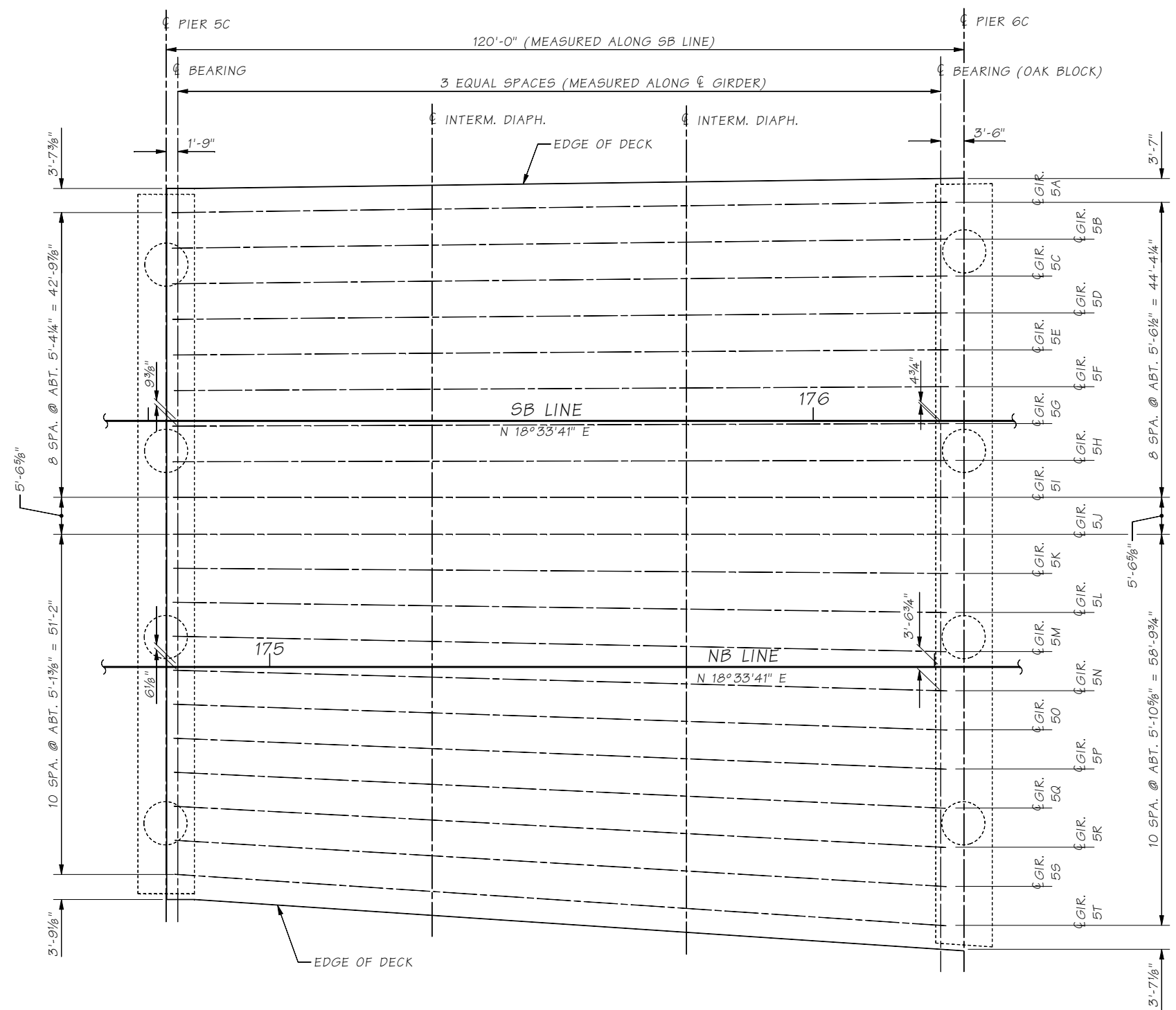

FRAMING PLAN - SPAN 5C
TRANSVERSE DIMENSIONS ARE MEASURED ALONG ϕ BEARING

Bridge Design Engr.	Khaleghi, B	M:\Y-Team\AWV SOUTH INTERCHANGE\window files\FRAMING PLAN SPAN 5C.WND			
Supervisor	Moore, TM	REGION NO.	STATE	FED. AID PROJ. NO.	SHEET NO.
Designed By	Mizumori, A	10	WASH.		TOTAL SHEETS
Checked By	Rodda, NT	JOB NUMBER			
Detailed By	Evans, A	09A803			
Bridge Projects Engr.		DATE	REVISION	BY	APPD
Prelim. Plan By					
Architect/Specialist					

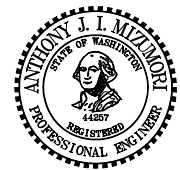

BRIDGE AND STRUCTURES OFFICE

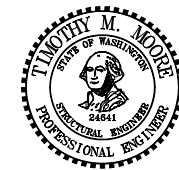

SR 99
ALASKAN WAY VIADUCT - REPLACEMENT
S HOLGATE ST TO S KING ST - PHASE 2
BRIDGE NO. 99/540 NB & SB
FRAMING PLAN SPAN 5C

BRIDGE SHEET NO. **BG158**
SHEET 1004 OF 1475 SHEETS

SR 99 FILE NO. SHEET BG159

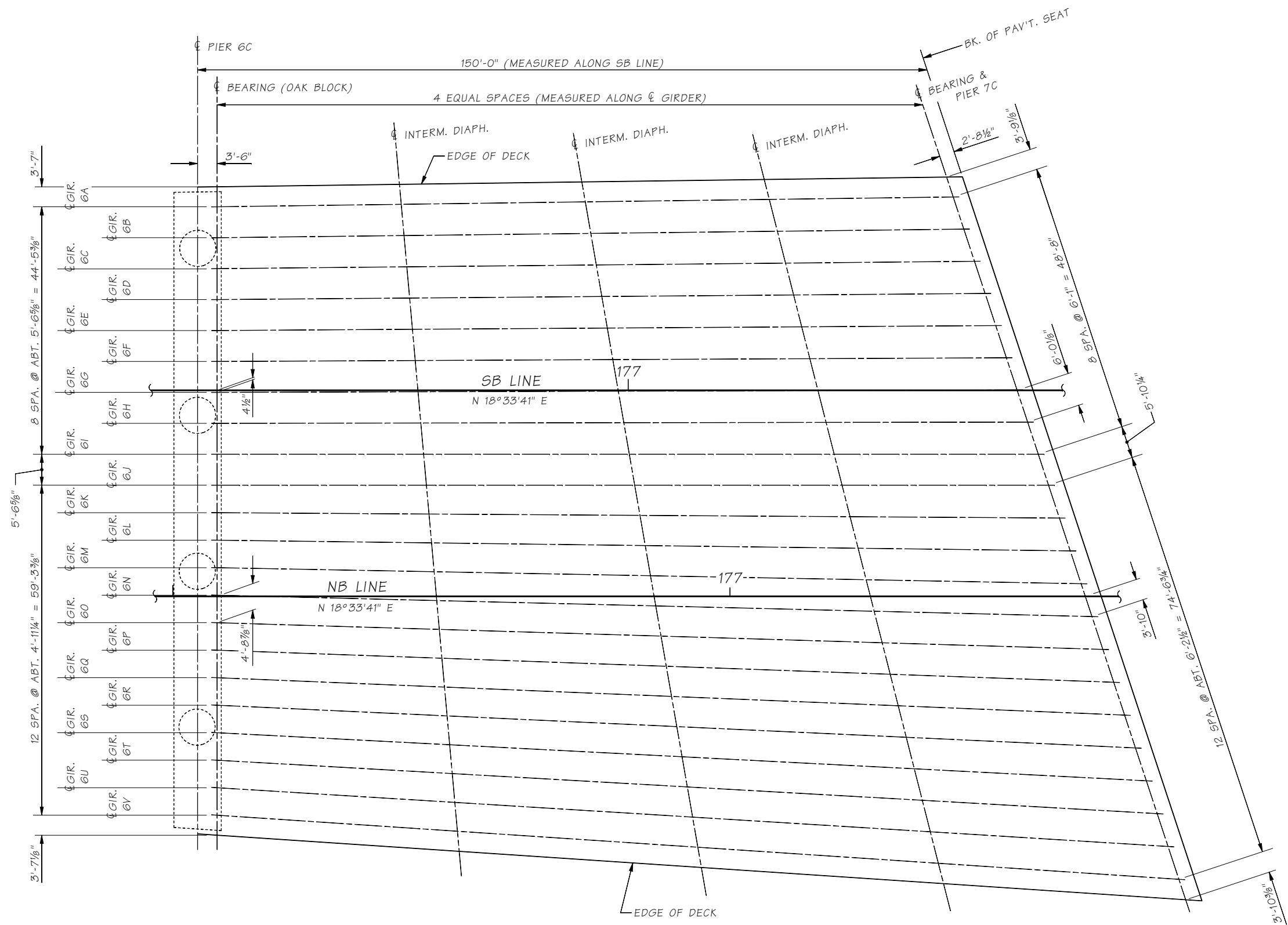

FRAMING PLAN - SPAN 6C
 TRANSVERSE DIMENSIONS ARE MEASURED ALONG ϕ BEARING

Bridge Design Engr.	Khaleghi, B	M:\Y-Team\AWV SOUTH INTERCHANGE\window files\FRAMING PLAN SPAN 6C.WND			
Supervisor	Moore, TM	REGION NO.	STATE	FED. AID PROJ. NO.	SHEET NO.
Designed By	Mizumori, A 10/08	10	WASH.		TOTAL SHEETS
Checked By	Rodda, NT 09/09	JOB NUMBER 09A803			
Detailed By	Evans, A 10/08				
Bridge Projects Engr.					
Prelim. Plan By					
Architect/Specialist		DATE	REVISION	BY	APPD



BRIDGE AND STRUCTURES OFFICE

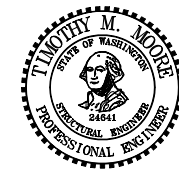

SR 99
 ALASKAN WAY VIADUCT - REPLACEMENT
 S HOLGATE ST TO S KING ST - PHASE 2
 BRIDGE NO. 99/540 NB & SB

FRAMING PLAN SPAN 6C

BRIDGE SHEET NO. BG159
 SHEET 1005 OF 1475 SHEETS